



PNEUMAX



PNEUMAX FLUID CONTROL

CATALOGUE



Pneumax Fluid Control Catalogue

Pneumax offers a wide range of brass and stainless steel valves and solenoid valves, suitable for use with liquid and gaseous fluids.



Pneumax Group

Smart Technologies and Human Competence

Founded in 1976, **Pneumax S.p.A.** is today one of the leading, international manufacturers of components and systems for automation. It is at the fore front of a group comprised of **25 companies**, with **over 800 employees worldwide**. Ongoing investment in research and development has allowed Pneumax to continually expand its range of standard products and customised solutions, adding to the well-established pneumatic technology, a range of electric drive actuators and fluid control components.

The desire to provide the service and specific application skills has led to the creation of 3 business units, dedicated to **Industrial Automation, Process Automation** and **Automotive sector**.

With the assistance of the specific Business unit Development Manager, Pneumax are able to design solutions than can add value to individual customer applications.



**Pneumatic
technology**

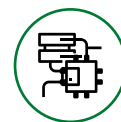

**Electric
actuation**



**Fluid
control**

Industrial automation



Process automation



Automotive



Components and systems for fluid control

The Pneumax range of components designed for the control and management of liquid and gaseous fluids have been manufactured using selected materials (valve bodies: brass, stainless steel, seals: FPM, PTFE & EPDM) in order to guarantee maximum reliability in harsh environments.

- ATEX versions available
- Solutions for low temperatures (>-40 °C) or high temperatures (< +140 °C)
- Wide range of components suitable for use with oxygen
-  certified solenoid coils

Pneumatic actuated
angle seat valve

Pad valves

Servo-assisted piston and
diaphragm solenoid valves



Direct acting poppet type
solenoid valves





















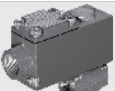

Index

Pneumax Fluid Control

Introduction

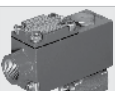





6

Direct acting poppet type solenoid valves 2/2 - 3/2 - Series F300





	F3105 - 2/2 Brass body - 1/8"	9		F3210 - 2/2 Stainless steel body - 1/4" ... 1/2"	22
	F3106 - 2/2 Brass body - 1/8" and 1/4"	10		F3211 - 2/2 Stainless steel body - 1/8"	23
	F3106 - 2/2 Stainless steel body - 3/8" and 1/2"	11		F3206 - 2/2 Brass body - 1/8" ... 1/2"	24 - 25
	FX3106 - 2/2 Brass body - 1/8" ... 1/2"	12 - 13		F3305 - 3/2 Brass body - 1/8"	26
	F3110 - 2/2 Stainless steel body - 1/4" ... 1/2"	14		F3306 - 3/2 Brass body - 1/8" and 1/4"	27
	FX3110 - 2/2 Stainless steel body - 1/4" ... 1/2"	15		F3310 - 3/2 Stainless steel body - 1/4"	28
	F3111 - 2/2 Stainless steel body - 1/8"	16		F3311 - 3/2 Stainless steel body - 1/8"	29
	F3115 - 2/2 Brass body - 1/8"	17		F332 - 3/2 Stainless steel body or anodised aluminium - 1/4"	30
	F3170 - 2/2 Stainless steel body - 1/4" ... 1/2"	18		F3371 - 3/2 Stainless steel body - 1/8"	31
	FX3170 - 2/2 Stainless steel body - 1/4" ... 1/2"	19		F3370 - 3/2 Stainless steel body - 1/4"	32
	F3171 - 2/2 Stainless steel body - 1/8"	20		FX3370 - 3/2 Stainless steel body - 1/4"	33
	F3271 - 2/2 Stainless steel body - 1/8"	21			







Servo-assisted diaphragm solenoid valves 2/2 - Series F300

	F3107 Brass body and cover 1/4" ... 1 1/4"	34		FX3177 Stainless steel body and cover 3/8" ... 1"	37
	FX3107 Brass body and cover 1/4" ... 3"	35		F3277 Stainless steel body and cover 3/8" ... 1"	38
	F3177 Stainless steel body and cover 3/8" ... 1"	36		F3207 Brass body and cover 1/4" ... 3"	39 - 40

Assisted-lift diaphragm solenoid valves 2/2 - Series F300

	F3108 Brass body and cover 3/8" ... 1"	41		FX3168 Brass body - 3/8" ... 1"	44
	F3168 Brass body and cover 3/8" ... 1" 1/2	42		FX3178 Stainless steel body - 3/8" ... 1"	45
	F3178 Stainless steel body and cover 3/8" ... 1" 1/2	43			





Servo-assisted piston solenoid valves 2/2 - Series F300

	F3119 Brass body and cover 1/4" ... 1/2"	46		F3124 Brass body and cover - 1/2"	49
	F3119W Brass body and cover 3/8" ... 1/2"	47		F3224 Brass body and cover - 1/2"	50
	F3123 Brass body and cover - 3/8"	48			

Solenoid coils - Series F300

	51
---	-----------

Pneumatic actuated angle seat valves 2/2 - Series PVF

	Connection type: threaded ports 1/2" ... 3"	52		Connection type: flange mounting	55
	Connection type: welded connection	53		Proximity sensor	56
	Connection type: clamp	54			

Pad valves 2/2 - Series PVA

	"T" body version	57		"Y" body version	58
---	-------------------------	-----------	---	-------------------------	-----------

Series F300

General

F300 series includes a vast range of solenoid valves in brass and stainless steel designed to control air, water, steam and all fluids that are compatible with the materials used for bodies and seals. The solenoid valves are 2 or 3-way, normally closed, normally open, general service, direct acting or servo-assisted, with connections available in NPT & BSP threads from G1/8" up to G3", with a working pressure range from vacuum to 100 bar. Solenoid valves are available with coils that conform to CESI 03 ATEX 344 certification for explosive environments. Our technical office ensures the highest standard of skill and understanding for the widest variety of applications, ensuring that the best possible solutions are found.

Version manufactured

Solenoid valves direct action 2-way: 2-way solenoid valves have an input connection and an output connection machined in the valve body, the orifice being intercepted by the poppet moved by the core tube.

They can be **normally closed (2/2 N.C.)**, in this case the fluid is intercepted by the poppet at rest, with electricity applied, the input orifice is opened and the media reaches the intended use.

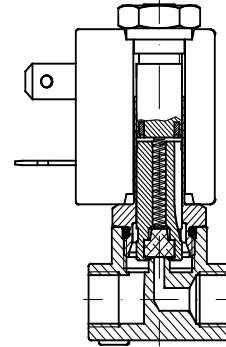

They can be **normally open (2/2 N.O.)**, in this case at rest the orifice remains open without electricity applied, the media reaches the intended use. When electricity is applied the input orifice closes.

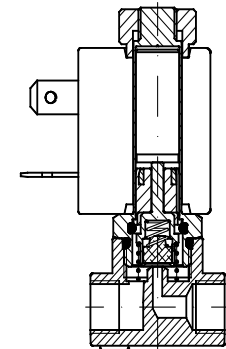

Performance in both cases depends solely on the magnetic field produced by the solenoid coil. The solenoid valves can also work at zero pressure.

Solenoid valves direct action 3-way: 3-way solenoid valves have an input and an output connection in the valve body and an exhaust connection fitted in the stem of the core tube. The input and exhaust orifices are intercepted directly by the poppet fitted within the core tube.

They can be **normally closed (3/2 N.C.)** and in this case, at rest, the incoming fluid is intercepted by the poppet and output port is connected to the exhaust port. Applying electrical power, the input orifice is opened and feed is supplied to the output. Exhaust is closed.

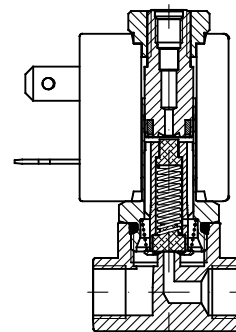

They can be **normally open (3/2 N.O.)** and in this case, at rest, the input orifice is open without electricity applied, the media reaches the intended use. Exhaust is closed. Applying power, the input orifice closes and the output discharges through the exhaust port.

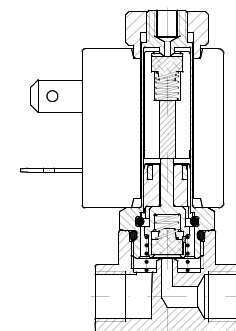

Performance in both cases depends solely on the magnetic field produced by the solenoid coil. The solenoid valves can also work at zero pressure.



Servo-assisted solenoid valves

Large-sized passage orifices increase the value of the static pressure which has to be overcome by the magnetic field produced by the coil. These solenoid valves are used to control high-pressure values with large diameter bores. In these models, the fluid helps in the opening or closing of the main poppet.

They can be **normally closed (2/2 N.C.)** and have an input and a utilisation connection machined into the valve body and at rest the fluid is intercepted by the main poppet, which can be either diaphragm or a piston. In this condition, the fluid acts on both faces of the main plunger through a pinhole contributing to closure of the poppet.

Applying electrical power, the secondary, or pilot, orifice opens leading to the exhaust of the fluid, which acts to close the main poppet.

Greater force is thus applied when opening, the poppet is raised from the orifice and allows the media to flows to the output.

In these versions, performance does not depend solely on the magnetic field produced by the coil; a minimum input pressure is also needed so as to move the diaphragm or the piston overcoming its rigidity and to keep it raised from the main orifice (Δp minimum performance).

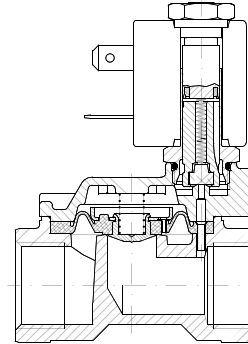

They can be **normally open (2/2 N.O.)** and have an input and output connection machined into the valve body, and at rest the core tube communicates with output, a minimum-pressure difference between the feed and the output causes the main poppet to rise, leading to it opening. Applying electrical power, the secondary orifice closes and equilibrium between the pressure on the two faces of the main poppet is reinstated, and so it returns to its closed position on the main orifice. In this version a minimum working pressure is also needed.

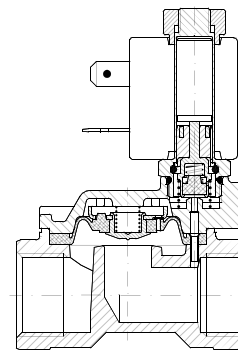

Sealing materials

Designation	Trade names	General characteristics	Field of use
FPM (Fluorocarbon)	VITON TECNOFON FLUOREL	A synthetic hexa-fluoropropylene-based elastomer. Excellent resistance to high temperatures. Excellent resistance to ozone, oxygen, mineral oils, synthetic hydraulic fluids, fuels, hydrocarbons and many chemical products. Not specific for superheated steam.	For general use up to 140 °C



Resistance to fluids

The table below serves to general information relating to the compatibility between FPM (fluorocarbon) and a number of neutral fluids. Where there are corrosive fluids, in order to establish compatibility, it is important to be aware of all the data relating to use: temperature, concentration and composition of the fluid.

Fluid	
Ethyl acetate	Not compatible
Acetylene	Compatible
Vinegar	Not compatible
Acetone	Not compatible
Calcareous water	Compatible
Hot water <75 °C	Compatible
Hot water and steam <140 °C	Not compatible
Water with glycol	Compatible
Deionised water	Compatible
Demineralised water	Compatible
Hydrogen peroxide	Compatible
Soapy water	Compatible
Carbon dioxide (liquid)	Not compatible
Dry carbon dioxide (gas)	Compatible
Argon	Compatible
Nitrogen	Compatible
Petrol/Gasoline	Compatible
Benzol	Not compatible
Butane	Compatible
Chloroform	Not compatible
Ethyl Chloride	Compatible
Methyl chloride	Not compatible
Helium	Compatible
Heptane	Compatible
Hexane	Compatible
Ethane	Compatible
Ethanol	Not compatible
Formaldehyde	Compatible
Freon	Not compatible
Natural gas	Compatible
Diesel oil	Compatible
Glycerine	Compatible
Ethylene glycol	Compatible
Hydrogen	Compatible
Isobutane	Compatible
Isopentane	Compatible
Methane	Compatible
Methanol	Not compatible
Calcium monoxide	Compatible
Neon	Compatible
Nitrobenzene	Not compatible
Mineral oil	Compatible
Oxygen	Compatible
Pentane-n	Compatible
Propanol-n	Compatible
Propane-n	Compatible
Carbon sulphide	Not compatible
Toluene	Compatible
Dry trichloroethylene	Compatible
Xylene	Compatible



F3105 - 2-way solenoid valve N.C. brass body, with G connection (ISO 228) - 1/8"

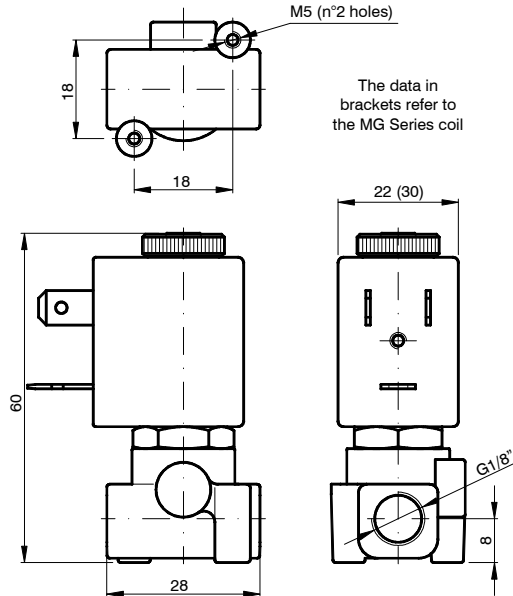

CODE "V" = FPM seals	G connection (ISO 228) ⊕ = Connection	Orifice (mm)	KV (m ³ /h)	Differential pressure (bar)		Power consumption			⊕ = Solenoid coil		Temperature range (°C)	
	A			Min	Max		AC Inrush (VA)	AC Holding (VA)	DC (W)	Series		Size
					AC	DC						
F3105⊕V12⊕	1/8"	1,2	0,04	0	25	25	12	8	6,5	MI	22	-10 ... +140
F3105⊕V15⊕		1,5	0,06		16	16						
F3105⊕V20⊕		2	0,09		12	10						
F3105⊕V25⊕		2,5	0,14		8	5,5						
F3105⊕V31⊕		3,1	0,19		5	2						
F3105⊕V40⊕		4	0,35		4	1,5						

N.B. For use with steam maximum admitted pressure PS is 2,5 bar (relative pressure).

Example: F3105⊕V25⊕ => F3105AV25MI58:

2-way solenoid valve normally closed, direct acting poppet type with G connection (ISO 228) 1/8", FPM seals, orifice 2,5 mm, solenoid coil 230 VAC (50-60 Hz) (MI58, size 22 for more information, please refer to the section "Solenoid coils - Series F300").

Pneumatic symbol

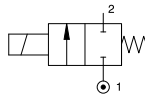

Diagram

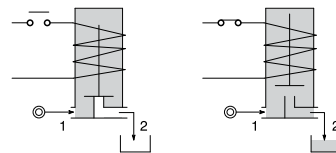

Construction characteristics	Technical characteristics	
- Brass body	Maximum admitted pressure (bar)	50
- Brass guide tube	Maximum fluid viscosity (mm ² /s)	25cSt
- AISI 430FR stainless steel mobile and fixed core	Ambient temperature: with class F solenoid coil (°C)	-10 ... +55
- AISI 302 stainless steel springs	Mounting position	Indifferent
- FPM sealing assemblies	Weight (g) with solenoid coil MI series	130
OPTIONS (on request):		
- Manual override	Weight (g) with solenoid coil MG series	180
- Chemical nickel plating surface treatment		
- Stainless steel guide tube		
- For use with oxygen		
- XME solenoid coil for potentially explosive environments to ATEX standards - Ex mb IIC		
- certified solenoid coils		
- Versions for use with fluid temperature at -40 °C		

F3106 - 2-way solenoid valve N.C. brass body, with G connection (ISO 228) - 1/8" and 1/4"

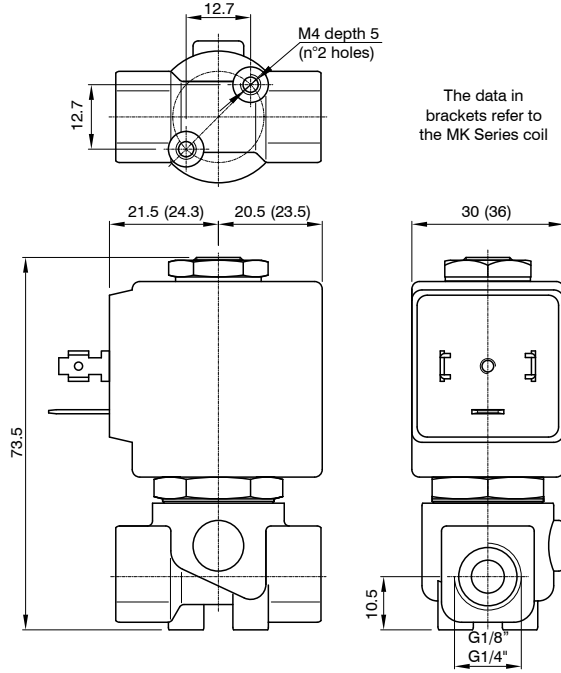

The data in brackets refer to the MK Series coil

CODE "V" = FPM seals	G connection (ISO 228) ⊕ = Connection		Orifice (mm)	KV (m³/h)	Differential pressure (bar)			Power consumption			⊕ = Solenoid coil		Temperature range (°C)
	A	B			Min	Max		AC Inrush (VA)	AC Holding (VA)	DC (W)	Series	Size	
						AC	DC						
F3106CV10⊕	1/8"	1/4"	1	0,04	0	80	80	20	15	10	MG	30	-10 ... +140
F3106CV12⊕			1,2	0,05		60	60						
F3106CV15⊕			1,5	0,07		30	26						
F3106CV20⊕			2	0,1		22	20						
F3106CV25⊕			2,5	0,15		16	14						
F3106CV30⊕			3	0,25		15	10						
F3106CV35⊕			3,5	0,32		10	8						
F3106CV40⊕			4	0,36		8	5						
F3106CV45⊕			4,5	0,41		6,5	3,5						
F3106CV52⊕			/	/		5,2	0,47						
F3106CV64⊕	/	/	6,4	0,64	3	1							
F3106CV10⊕	1/8"	1/4"	1	0,04	0	100	100	40	30	27	MK	36	-10 ... +140
F3106CV12⊕			1,2	0,05		100	100						
F3106CV15⊕			1,5	0,07		80	80						
F3106CV20⊕			2	0,1		50	40						
F3106CV25⊕			2,5	0,15		35	33						
F3106CV30⊕			3	0,25		25	24						
F3106CV35⊕			3,5	0,32		20	19						
F3106CV40⊕			4	0,36		16	15						
F3106CV45⊕			4,5	0,41		14	13						
F3106CV52⊕			/	/		5,2	0,47						
F3106CV64⊕	/	/	6,4	0,64	5	4,5							

N.B. For use with steam, maximum admitted pressure PS is 9 bar (relative pressure) with seals in PTFE and 2.5 bar with seals in EPDM.

Example: F3106CV52⊕ => F3106BV52MG58:

2-way solenoid valve normally closed, direct acting poppet type with G connection (ISO 228) 1/4", FPM seals, 5,2 mm orifice, solenoid coil 230 VAC (50-60 Hz) (MG58, size 30 for more information, please refer to the section "Solenoid coils - Series F300").

Pneumatic symbol

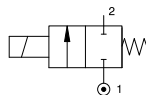

Diagram

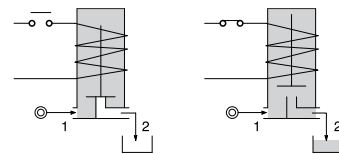

Construction characteristics

- Brass body
- AISI 303 stainless steel guide tube
- AISI 430FR stainless steel mobile and fixed core
- AISI 302 stainless steel springs
- FPM sealing assemblies

OPTIONS (on request):

- Manual override
- Chemical nickel plating surface treatment
- Stainless steel seat insert (up to Ø4,5)
- For use with oxygen
- CE certified solenoid coils
- Versions for use with fluid temperature at -40 °C
- PTFE - EPDM seals

Technical characteristics

Maximum admitted pressure (bar)	100
Maximum fluid viscosity (mm²/s)	25cSt
Ambient temperature: with class F solenoid coil (°C)	-10 ... +55
Ambient temperature: with class H solenoid coil (°C)	-10 ... +80
Mounting position	Indifferent
Weight (g) with solenoid coil MG series	300
Weight (g) with solenoid coil MK series	380



F3106 - 2-way solenoid valve N.C. brass body, with G connection (ISO 228) - 3/8" and 1/2"

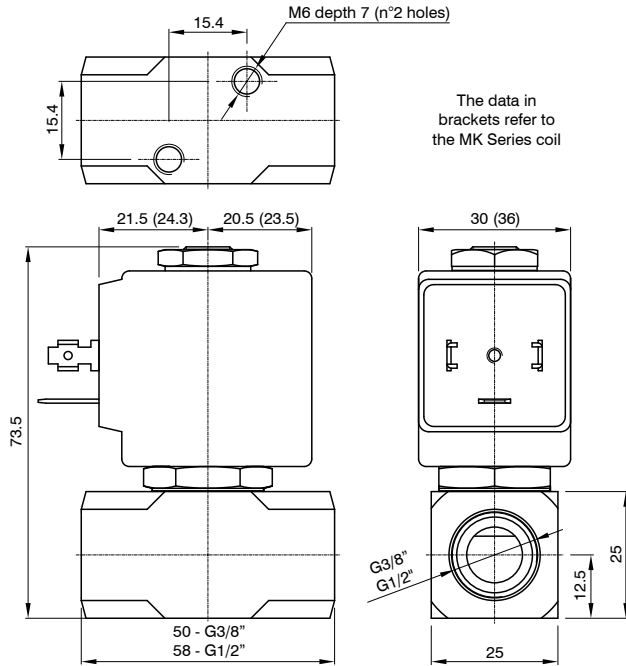

CODE "V" = FPM seals	G connection (ISO 228) ⊕ = Connection		Orifice (mm)	KV (m³/h)	Differential pressure (bar)			Power consumption			⊕ = Solenoid coil		Temperature range (°C)
	C	D			Min	Max		AC Inrush (VA)	AC Holding (VA)	DC (W)	Series	Size	
						AC	DC						
F3106⊕V10⊕	3/8"	1/2"	1	0,04	0	80	80	20	15	10	MG	30	-10 ... +140
F3106⊕V12⊕			1,2	0,05		60	60						
F3106⊕V15⊕			1,5	0,07		30	26						
F3106⊕V20⊕			2	0,1		22	20						
F3106⊕V25⊕			2,5	0,15		16	14						
F3106⊕V30⊕			3	0,25		15	10						
F3106⊕V35⊕			3,5	0,32		10	8						
F3106⊕V40⊕			4	0,36		8	5						
F3106⊕V45⊕			4,5	0,41		6,5	3,5						
F3106⊕V52⊕			5,2	0,47		4	1,8						
F3106⊕V64⊕	6,4	0,64	3	1									
F3106⊕V10⊕	3/8"	1/2"	1	0,04	0	100	100	40	30	27	MK	36	-10 ... +140
F3106⊕V12⊕			1,2	0,05		100	100						
F3106⊕V15⊕			1,5	0,07		80	80						
F3106⊕V20⊕			2	0,1		50	40						
F3106⊕V25⊕			2,5	0,15		35	33						
F3106⊕V30⊕			3	0,25		25	24						
F3106⊕V35⊕			3,5	0,32		20	19						
F3106⊕V40⊕			4	0,36		16	15						
F3106⊕V45⊕			4,5	0,41		14	13						
F3106⊕V52⊕			5,2	0,47		10	9						
F3106⊕V64⊕	6,4	0,64	5	4,5									

N.B. For use with steam, maximum admitted pressure PS is 9 bar (relative pressure) with seals in PTFE and 2.5 bar with seals in EPDM.

Example: F3106⊕V52⊕ => F3106DV52MK5:

2-way solenoid valve normally closed, direct acting poppet type with G connection (ISO 228) 1/2", FPM seals, 5,2 mm orifice, solenoid coil 24 VDC (MK5, size 36 for more information, please refer to the section "Solenoid coils - Series F300").

Pneumatic symbol

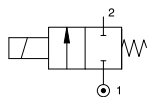

Diagram

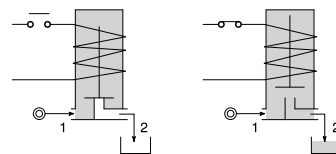

Construction characteristics	Technical characteristics	
<ul style="list-style-type: none"> - Brass body - AISI 303 stainless steel guide tube - AISI 430FR stainless steel mobile and fixed core - AISI 302 stainless steel springs - FPM sealing assemblies 	Maximum admitted pressure (bar)	100
	Maximum fluid viscosity (mm²/s)	25cSt
	Ambient temperature: with class F solenoid coil (°C)	-10 ... +55
	Ambient temperature: with class H solenoid coil (°C)	-10 ... +80
	Mounting position	Indifferent
	Weight (g) with solenoid coil MG series	360
	Weight (g) with solenoid coil MK series	440

OPTIONS (on request):

- Chemical nickel plating surface treatment
- For use with oxygen
- Stainless steel seat insert (up to Ø4,5)
- certified solenoid coils
- Versions for use with fluid temperature at -40 °C
- PTFE - EPDM seals

**FX3106 - 2-way solenoid valve N.C. brass body, with G connection (ISO 228)
with certified housing: Ex d IIC T6 or T5 or T4 Gb - 1/8" and 1/4"**

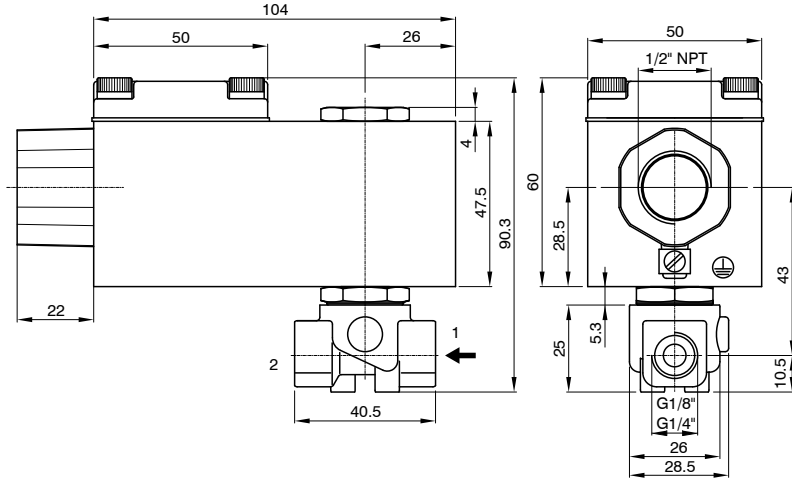

CODE "V" = FPM seals	G connection (ISO 228) ⊕ = Connection		Orifice (mm)	KV (m³/h)	Differential pressure (bar)		Power consumption		⊕ = Solenoid coil	Temperature range (°C)		
	A	B			Min	Max		AC Holding (VA)			DC (W)	
						AC	DC					
FX3106⊕V10⊕	1/8"	1/4"	1	0,04	0	80	80	12	8	A6B= 24 Volt (AC 50-60 Hz) A6E= 220/230 Volt (AC 50-60 Hz) A60= 12 Volt (DC) A61= 24 Volt (DC)	-10 ... +80	
FX3106⊕V12⊕			1,2	0,05		60	60					
FX3106⊕V15⊕			1,5	0,07		30	26					
FX3106⊕V20⊕			2	0,1		22	20					
FX3106⊕V25⊕			2,5	0,15		16	14					
FX3106⊕V30⊕			3	0,25		15	10					
FX3106⊕V35⊕			3,5	0,32		10	8					
FX3106⊕V40⊕			/	4		0,36	8					5
FX3106⊕V45⊕			/	4,5		0,41	6,5					3,5
FX3106⊕V52⊕			/	5,2		0,47	4					1,8
FX3106⊕V64⊕	/	6,4	0,64	3	1							

N.B. The solenoid valve is suited for intercepting only fluids that are NOT potentially explosive.

Example: FX3106⊕V35⊕ => FX3106BV35A60:

2-way solenoid valve normally closed, direct acting poppet type with certified housing: Ex d IIC T6 or T5 or T4 Gb, with G connection (ISO 228) 1/4", FPM seals, 3,5 mm orifice, solenoid coil 12 VDC (A60).

Pneumatic symbol

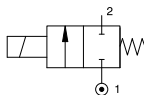

Diagram

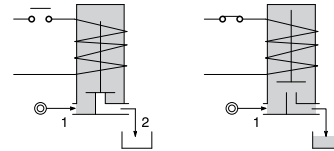

Construction characteristics

- Brass body
- Red light alloy housing
- 1/2" NPT electrical connection (M20x1,5 on request)
- FPM sealing assemblies

OPTIONS (on request):

- Manual override
- Chemical nickel plating surface treatment
- Stainless steel seat insert (up to Ø4,5)
- Stainless steel solenoid coil housing

Technical characteristics

Maximum admitted pressure (bar)	100
Maximum fluid viscosity (mm²/s)	25cSt
Ambient temperature (°C)	-40 ... +60
Mounting position	Vertical with solenoid coil upwards
Weight (g)	600



**FX3106 - 2-way solenoid valve N.C. brass body, with G connection (ISO 228)
with certified housing: Ex d IIC T6 or T5 or T4 Gb - 3/8 and 1/2"**

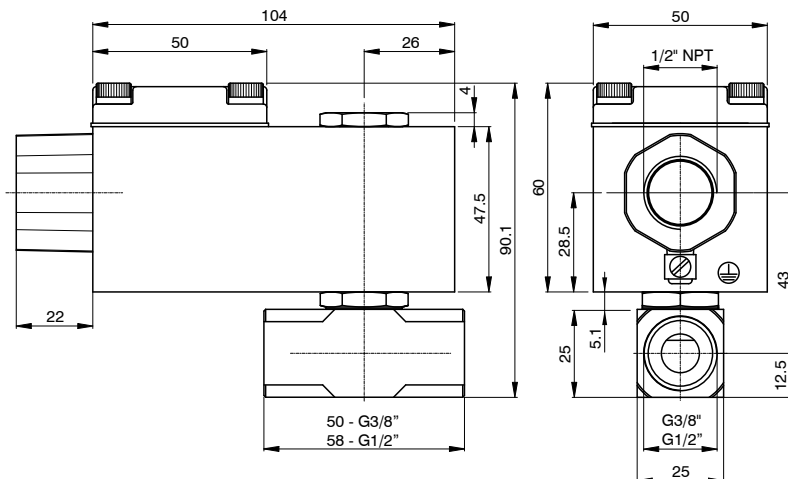

CODE "V" = FPM seals	G connection (ISO 228) ⊕ = Connection		Orifice (mm)	KV (m ³ /h)	Differential pressure (bar)		Power consumption		⊖ = Solenoid coil	Temperature range (°C)	
	C	D			Min	Max	AC Holding (VA)	DC (W)			
FX3106⊕V10⊖	3/8"	1/2"	1	0,04	0	80	80	12	8	A6B= 24 Volt (AC 50-60 Hz) A6E= 220/230 Volt (AC 50-60 Hz) A60= 12 Volt (DC) A61= 24 Volt (DC)	-10 ... +80
FX3106⊕V12⊖			1,2	0,05		60	60				
FX3106⊕V15⊖			1,5	0,07		30	26				
FX3106⊕V20⊖			2	0,1		22	20				
FX3106⊕V25⊖			2,5	0,15		16	14				
FX3106⊕V30⊖			3	0,25		15	10				
FX3106⊕V35⊖			3,5	0,32		10	8				
FX3106⊕V40⊖			4	0,36		8	5				
FX3106⊕V45⊖			4,5	0,41		6,5	3,5				
FX3106⊕V52⊖			5,2	0,47		4	1,8				
FX3106⊕V64⊖	6,4	0,64	3	1							

N.B. The solenoid valve is suited for intercepting only fluids that are NOT potentially explosive.

Example: FX3106⊕V52⊖ => FX3106DV52A60:

2-way solenoid valve normally closed, direct acting poppet type with certified housing: Ex d IIC T6 or T5 or T4 Gb, with G connection (ISO 228) 1/2", FPM seals, 5,2 mm orifice, solenoid coil 12 VDC (A60).

Pneumatic symbol

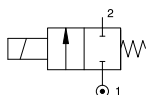

Diagram

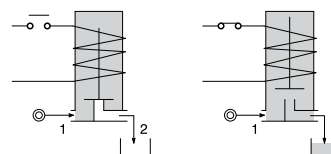

Construction characteristics

- Brass body
- Red light alloy housing
- 1/2" NPT electrical connection (M20x1,5 on request)
- FPM sealing assemblies

OPTIONS (on request):

- Chemical nickel plating surface treatment
- Stainless steel seat insert (up to Ø4,5)
- Stainless steel solenoid coil housing

Technical characteristics

Maximum admitted pressure (bar)	100
Maximum fluid viscosity (mm ² /s)	25cSt
Ambient temperature (°C)	-40 ... +60
Mounting position	Vertical with solenoid coil upwards
Weight (g)	660

F3110 - 2-way solenoid valve N.C. stainless steel body, with G connection (ISO 228) - 1/4" ... 1/2"

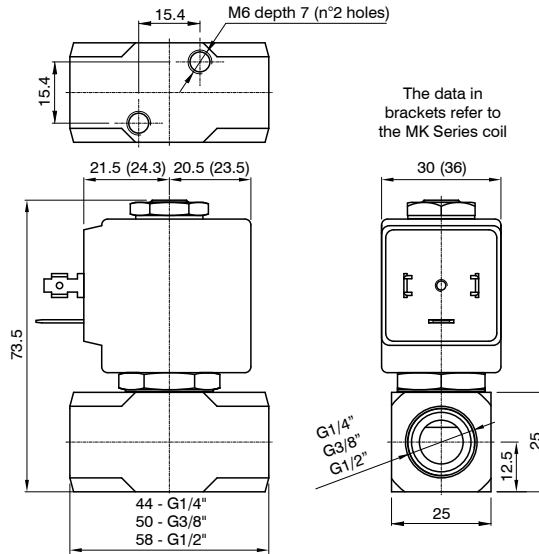

CODE "V" = FPM seals	G connection (ISO 228) ⊕ = Connection			Orifice (mm)	KV (m ³ /h)	Differential pressure (bar)		Power consumption			⊕ = Solenoid coil		Temperature range (°C)	
	B	C	D			Min	Max		AC Inrush (VA)	AC Holding (VA)	DC (W)	Series		Size
							AC	DC						
F3110CV10B	1/4"	3/8"	1/2"	1	0,04	0	80	80	20	15	10	MG	30	-10 ... +140
F3110CV12B				1,2	0,05		60	60						
F3110CV15B				1,5	0,07		30	26						
F3110CV20B				2	0,1		22	20						
F3110CV25B				2,5	0,15		16	14						
F3110CV30B				3	0,25		15	10						
F3110CV35B				3,5	0,32		10	8						
F3110CV40B				4	0,36		8	5						
F3110CV45B				4,5	0,41		6,5	3,5						
F3110CV52B				5,2	0,47		4	1,8						
F3110CV64B	6,4	0,64	3	1										
F3110CV10B	1/4"	3/8"	1/2"	1	0,04	0	100	100	40	30	27	MK	36	-10 ... +140
F3110CV12B				1,2	0,05		100	100						
F3110CV15B				1,5	0,07		80	80						
F3110CV20B				2	0,1		50	40						
F3110CV25B				2,5	0,15		35	33						
F3110CV30B				3	0,25		25	24						
F3110CV35B				3,5	0,32		20	19						
F3110CV40B				4	0,36		16	15						
F3110CV45B				4,5	0,41		14	13						
F3110CV52B				5,2	0,47		10	9						
F3110CV64B	6,4	0,64	5	4,5										

N.B. For use with steam, maximum admitted pressure PS is 9 bar (relative pressure) with seals in PTFE and 2.5 bar with seals in EPDM.

Example: F3110CV25B => F3110BV25MG5:

2-way solenoid valve normally closed, direct acting poppet type with G connection (ISO 228) 1/4", FPM seals, 2,5 mm orifice, solenoid coil 24 VDC (MG5, size 30 for more information, please refer to the section "Solenoid coils - Series F300").

Pneumatic symbol

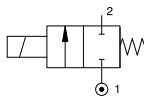

Diagram

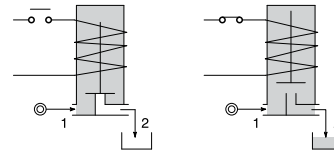

Construction characteristics

- AISI 303 stainless steel body
- AISI 303 stainless steel guide tube
- AISI 430FR stainless steel mobile and fixed core
- AISI 302 stainless steel springs
- FPM sealing assemblies

OPTIONS (on request):

- Silver advance ring
- For use with oxygen
- certified solenoid coils
- Versions for use with fluid temperature at -40 °C
- PTFE - EPDM seals

Technical characteristics

Maximum admitted pressure (bar)	100
Maximum fluid viscosity (mm ² /s)	25cSt
Ambient temperature: with class F solenoid coil (°C)	-10 ... +55
Ambient temperature: with class H solenoid coil (°C)	-10 ... +80
Mounting position	Indifferent
Weight (g) with solenoid coil MG series	360
Weight (g) with solenoid coil MK series	440



**FX3110 - 2-way solenoid valve N.C. stainless steel body, with G connection (ISO 228)
with certified housing: Ex d IIC T6 or T5 or T4 Gb - 1/4" ... 1/2"**

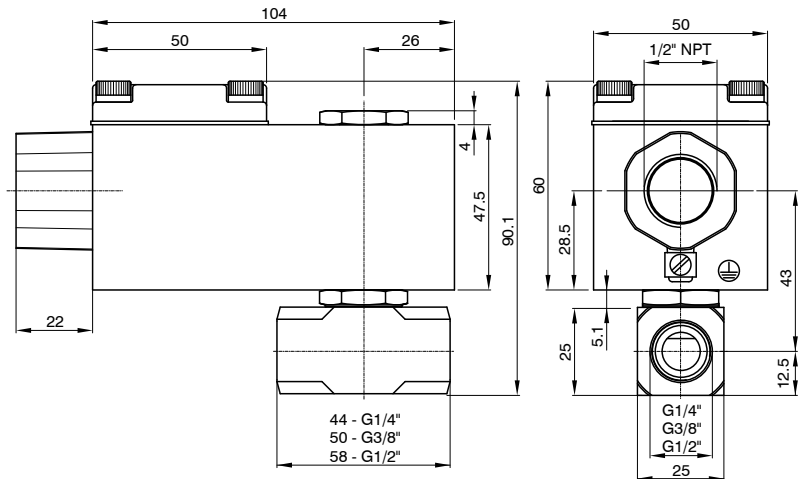

CODE "V" = FPM seals	G connection (ISO 228) ⊙ = Connection			Orifice (mm)	KV (m ² /h)	Differential pressure (bar)		Power consumption		⊙ = Solenoid coil	Temperature range (°C)	
	B	C	D			Min	Max		AC Holding (VA)			DC (W)
							AC	DC				
FX3110⊙V10⊕	1/4"	3/8"	1/2"	1	0,04	0	80	80	12	8	A6B= 24 Volt (AC 50-60 Hz) A6E= 220/230 Volt (AC 50-60 Hz) A60= 12 Volt (DC) A61= 24 Volt (DC)	-10 ... +80
FX3110⊙V12⊕				1,2	0,05		60	60				
FX3110⊙V15⊕				1,5	0,07		30	26				
FX3110⊙V20⊕				2	0,1		22	20				
FX3110⊙V25⊕				2,5	0,15		16	14				
FX3110⊙V30⊕				3	0,25		15	10				
FX3110⊙V35⊕				3,5	0,32		10	8				
FX3110⊙V40⊕				4	0,36		8	5				
FX3110⊙V45⊕				4,5	0,41		6,5	3,5				
FX3110⊙V52⊕				5,2	0,47		4	1,8				
FX3110⊙V64⊕	6,4	0,64	3,5	1								

N.B. The solenoid valve is suited for intercepting only fluids that are NOT potentially explosive.

Example: FX3110⊙V52⊕ => FX3110DV52A60:

2-way solenoid valve normally closed, direct acting poppet type with certified housing: Ex d IIC T6 or T5 or T4 Gb, with G connection (ISO 228) 1/2", FPM seals, 5,2 mm orifice, solenoid coil 12 VDC (A60).

Pneumatic symbol

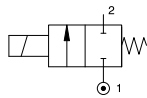

Diagram

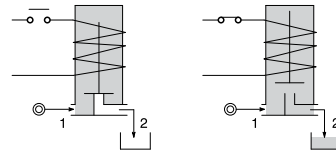

Construction characteristics	Technical characteristics	
- AISI 303 stainless steel body	Maximum admitted pressure (bar)	100
- AISI 303 stainless steel guide tube	Maximum fluid viscosity (mm ² /s)	25cSt
- AISI 302 stainless steel springs	Ambient temperature (°C)	-40 ... +60
- Red light alloy or stainless steel housing	Mounting position	Vertical with solenoid coil upwards
- 1/2" NPT electrical connection (M20x1,5 on request)	Weight (g)	660
- FPM sealing assemblies		

F3111 - 2-way solenoid valve N.C. stainless steel body, with G connection (ISO 228) - 1/8"

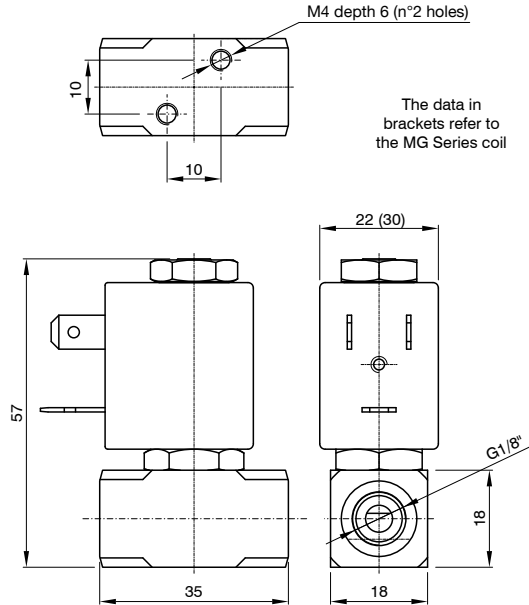

CODE "V" = FPM seals	G connection (ISO 228) ⊕ = Connection	Orifice (mm)	KV (m³/h)	Differential pressure (bar)			Power consumption			⊕ = Solenoid coil		Temperature range (°C)	
				Min	Max		AC Inrush (VA)	AC Holding (VA)	DC (W)	Series	Size		
					AC	DC							
F3111⊕V12⊕	1/8"	1,2	0,04	0	25	25	12	8	6,5	MI	22	-10 ... +140	
F3111⊕V15⊕		1,5	0,06		16	16							
F3111⊕V20⊕		2	0,09		12	10							
F3111⊕V25⊕		2,5	0,14		8	5,5							
F3111⊕V31⊕		3,1	0,19		5	2							
F3111⊕V20⊕	1/8"	2	0,09	15	16	8	11	5	MG	30			
F3111⊕V25⊕		2,5	0,14								25		15
F3111⊕V25⊕		2,5	0,14								16		8
F3111⊕V31⊕		3,1	0,19								8		4

N.B. For use with steam maximum admitted pressure PS is 2,5 bar (relative pressure).

Example: F3111⊕V25⊕ => F3111AV25MI58:

2-way solenoid valve normally closed, direct acting poppet type with G connection (ISO 228) 1/8", FPM seals, 2,5 mm orifice, solenoid coil 230 VAC (50-60 Hz) (MI58, size 22 for more information, please refer to the section "Solenoid coils - Series F300").

Pneumatic symbol

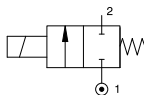

Diagram

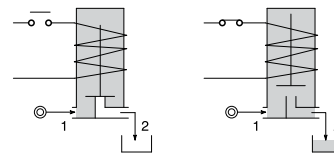

Construction characteristics

- AISI 303 stainless steel body
- AISI 303 stainless steel guide tube
- AISI 430FR stainless steel mobile and fixed core
- AISI 302 stainless steel springs
- FPM sealing assemblies

OPTIONS (on request):

- Silver advance ring
- For use with oxygen
- XME solenoid coil for potentially explosive environments to ATEX standards - Ex mb IIC
- CE certified solenoid coils
- Versions for use with fluid temperature at -40 °C

Technical characteristics

Maximum admitted pressure (bar)	50
Maximum fluid viscosity (mm²/s)	25cSt
Ambient temperature: with class F solenoid coil (°C)	-10 ... +55
Mounting position	Indifferent
Weight (g) with solenoid coil MI series	150
Weight (g) with solenoid coil MG series	200



F3115 - 2-way solenoid valve brass body, with G connection (ISO 228) bistable impulse drive - 1/8"



The bistable function is achieved by the use of a polarized permanent magnet energizing the coil with a DC current for at least 15ms in the reverse direction of the preceding impulse.

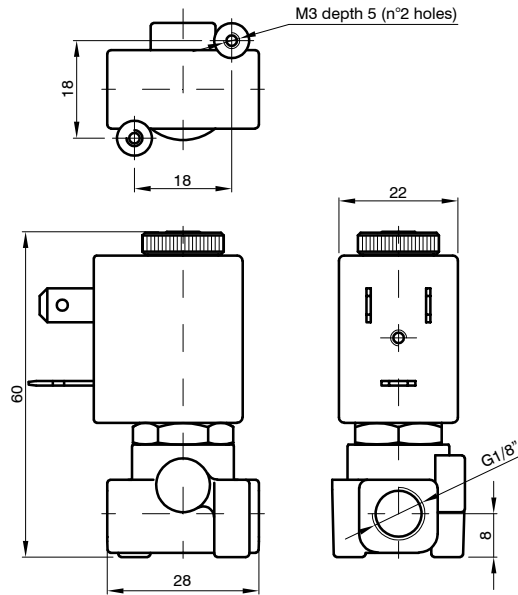

CODE "V" = FPM seals	G connection (ISO 228) ⊕ = Connection A	Orifice (mm)	KV (m ³ /h)	Differential pressure (bar)		Power consumption DC (W)	⊕ = Solenoid coil		Temperature range (°C)
				Min	Max		Series	Size	
F3115⊕V12⊕	1/8"	1,2	0,04	0	12	2	MI/DC	22	-10 ... +120
F3115⊕V15⊕					8	2			
F3115⊕V20⊕		2	0,09		20	5			
					12	5			
F3115⊕V25⊕		2,5	0,14		1	2			
					5	5			
F3115⊕V31⊕		3,1	0,19		8	6,5			
					2	5			
					3,5	6,5			

Example: F3115⊕V25⊕ => F3115AV25MI5:

2-way solenoid valve, direct acting poppet type with G connection (ISO 228) 1/8", FPM seals, 2,5 mm orifice, solenoid coil 24 VDC (MI5, size 22 for more information, please refer to the section "Solenoid coils - Series F300").

Pneumatic symbol

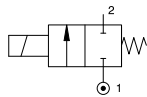

Diagram

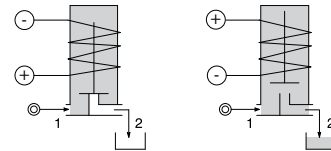

Construction characteristics	Technical characteristics	
<ul style="list-style-type: none"> - Brass body - Brass guide tube - AISI 430FR stainless steel mobile and fixed core - AISI 302 stainless steel springs - FPM sealing assemblies OPTIONS (on request): <ul style="list-style-type: none"> - Chemical nickel plating surface treatment - Stainless steel guide tube - XME solenoid coil for potentially explosive environments to ATEX standards - Ex mb IIC 	Maximum admitted pressure (bar)	50
	Maximum fluid viscosity (mm ² /s)	25cSt
	Ambient temperature: with class F solenoid coil (°C)	-10 ... +55
	Mounting position	Indifferent
	Weight (g)	140

F3170 - 2-way solenoid valve N.C. stainless steel body, with G connection (ISO 228) - 1/4" ... 1/2"

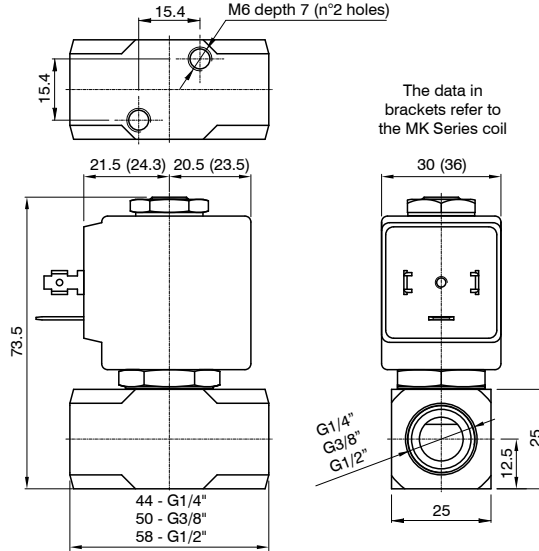

CODE "V" = FPM seals	G connection (ISO 228) ⊕ = Connection			Orifice (mm)	KV (m³/h)	Differential pressure (bar)		Power consumption			⊕ = Solenoid coil		Temperature range (°C)	
	B	C	D			Min	Max	AC Inrush (VA)	AC Holding (VA)	DC (W)	Series	Size		
														AC
F3170CV10B	1/4"	3/8"	1/2"	1	0,04	0	80	80	20	15	10	MG	30	-10 ... +140
F3170CV12B				1,2	0,05		60	60						
F3170CV15B				1,5	0,07		30	26						
F3170CV20B				2	0,1		22	20						
F3170CV25B				2,5	0,15		16	14						
F3170CV30B				3	0,25		15	10						
F3170CV35B				3,5	0,32		10	8						
F3170CV40B				4	0,36		8	5						
F3170CV45B				4,5	0,41		6,5	3,5						
F3170CV10B	1/4"	3/8"	1/2"	1	0,04	0	100	100	40	30	27	MK	36	
F3170CV12B				1,2	0,05		100	100						
F3170CV15B				1,5	0,07		80	80						
F3170CV20B				2	0,1		50	40						
F3170CV25B				2,5	0,15		35	33						
F3170CV30B				3	0,25		25	24						
F3170CV35B				3,5	0,32		20	19						
F3170CV40B				4	0,36		16	15						
F3170CV45B				4,5	0,41		14	13						

N.B. For use with steam, maximum admitted pressure PS is 9 bar (relative pressure) with seals in PTFE and 2.5 bar with seals in EPDM.

Example: F3170CV25B => F3170BV25MG5:

2-way solenoid valve normally closed, direct acting poppet type with G connection (ISO 228) 1/4", FPM seals, 2,5 mm orifice, solenoid coil 24 VDC (MG5, size 30 for more information, please refer to the section "Solenoid coils - Series F300").

Pneumatic symbol

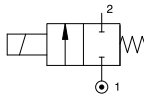

Diagram

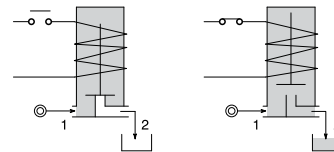

Construction characteristics

- AISI 316 stainless steel body
- AISI 316 stainless steel guide tube
- AISI 430FR stainless steel mobile and fixed core
- AISI 316 stainless steel springs
- Silver advance ring
- FPM sealing assemblies

OPTIONS (on request):

- For use with oxygen
- CE certified solenoid coils
- Versions for use with fluid temperature at -40 °C
- PTFE - EPDM seals

Technical characteristics

Maximum admitted pressure (bar)	100
Maximum fluid viscosity (mm²/s)	25cSt
Ambient temperature: with class F solenoid coil (°C)	-10 ... +55
Ambient temperature: with class H solenoid coil (°C)	-10 ... +80
Mounting position	Indifferent
Weight (g) with solenoid coil MG series	360
Weight (g) with solenoid coil MK series	440



**FX3170 - 2-way solenoid valve N.C. stainless steel body, with G connection (ISO 228)
with certified housing: Ex d IIC T6 or T5 or T4 Gb - 1/4" ... 1/2"**

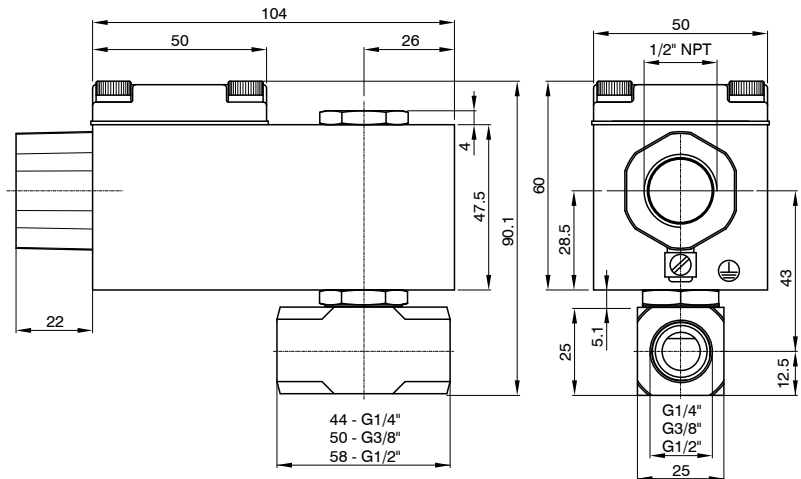

CODE "V" = FPM seals	G connection (ISO 228) ⊕ = Connection			Orifice (mm)	KV (m ² /h)	Differential pressure (bar)		Power consumption		⊕ = Solenoid coil	Temperature range (°C)	
	B	C	D			Min	Max		AC Holding (VA)			DC (W)
							AC	DC				
FX3170⊕V10⊕	1/4"	3/8"	1/2"	1	0,04	0	80	80	12	8	A6B= 24 Volt (AC 50-60 Hz) A6E= 220/230 Volt (AC 50-60 Hz) A60= 12 Volt (DC) A61= 24 Volt (DC)	-10 ... +80
FX3170⊕V12⊕				1,2	0,05		60	60				
FX3170⊕V15⊕				1,5	0,07		30	26				
FX3170⊕V20⊕				2	0,1		22	20				
FX3170⊕V25⊕				2,5	0,15		16	14				
FX3170⊕V30⊕				3	0,25		15	10				
FX3170⊕V35⊕				3,5	0,32		10	8				
FX3170⊕V40⊕				4	0,36		8	5				
FX3170⊕V45⊕				4,5	0,41		6,5	3,5				

N.B. The solenoid valve is suited for intercepting only fluids that are NOT potentially explosive.

Example: FX3170⊕V45⊕ => FX3170DV45A60:

2-way solenoid valve normally closed, direct acting poppet type with certified housing: Ex d IIC T6 or T5 or T4 Gb, with G connection (ISO 228) 1/2", FPM seals, 4,5 mm orifice, solenoid coil 12 VDC (A60).

Pneumatic symbol

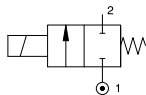

Diagram

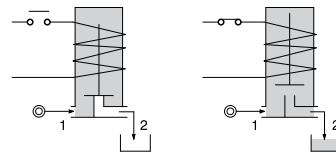

Construction characteristics	Technical characteristics	
- AISI 316 stainless steel body	Maximum admitted pressure (bar)	100
- AISI 316 stainless steel guide tube	Maximum fluid viscosity (mm ² /s)	25cSt
- AISI 430FR stainless steel mobile and fixed core	Ambient temperature (°C)	-40 ... +60
- Silver advance ring	Mounting position	Vertical with solenoid coil upwards
- AISI 316 stainless steel springs	Weight (g)	660
- Red light alloy or stainless steel housing		
- 1/2" NPT electrical connection (M20x1,5 on request)		
- FPM sealing assemblies		

F3171 - 2-way solenoid valve N.C. stainless steel body, with G connection (ISO 228) - 1/8"

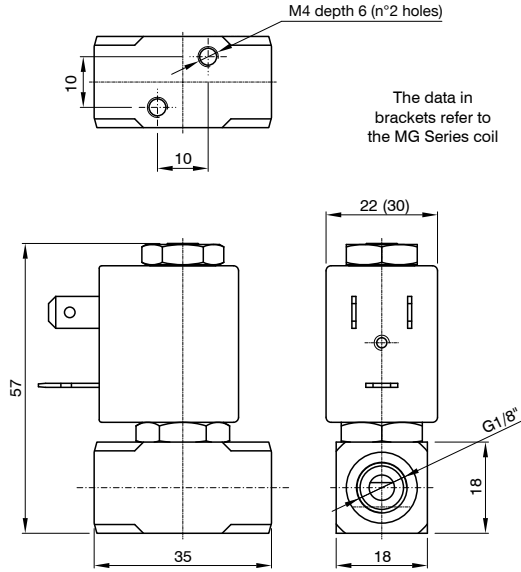

CODE "V" = FPM seals	G connection (ISO 228) ⊕ = Connection	Orifice (mm)	KV (m³/h)	Differential pressure (bar)		Power consumption			⊕ = Solenoid coil		Temperature range (°C)	
				Min	Max	AC Inrush (VA)	AC Holding (VA)	DC (W)	Series	Size		
F3171⊕V12⊕	1/8"	1,2	0,04	0	25	25	12	8	6,5	MI	22	-10 ... +140
F3171⊕V15⊕		1,5	0,06		16	16						
F3171⊕V20⊕		2	0,09		12	10						
F3171⊕V25⊕		2,5	0,14		8	5,5						
F3171⊕V31⊕		3,1	0,19		5	2						
F3171⊕V20⊕	1/8"	2	0,09	25	15	15	11	5	MG	30		
F3171⊕V25⊕		2,5	0,14	16	8							
F3171⊕V31⊕		3,1	0,19	8	4							

N.B. For use with steam maximum admitted pressure PS is 2,5 bar (relative pressure).

Example: F3171⊕V25⊕ => F3171AV25MI58:

2-way solenoid valve normally closed, direct acting poppet type with G connection (ISO 228) 1/8", FPM seals, 2,5 mm orifice, solenoid coil 230 VAC (50-60 Hz) (MI58, size 22 for more information, please refer to the section "Solenoid coils - Series F300").

Pneumatic symbol

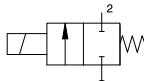

Diagram

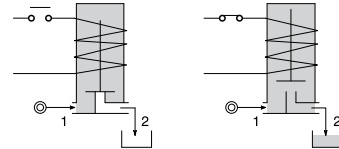

Construction characteristics	Technical characteristics	
<ul style="list-style-type: none"> - AISI 316 stainless steel body - AISI 316 stainless steel guide tube - AISI 430FR stainless steel mobile and fixed core - Silver advance ring - AISI 316 stainless steel springs - FPM sealing assemblies <p>OPTIONS (on request):</p> <ul style="list-style-type: none"> - For use with oxygen - XME solenoid coil for potentially explosive environments to ATEX standards - Ex mb IIC - CE certified solenoid coils - Versions for use with fluid temperature at -40 °C 	<p>Maximum admitted pressure (bar)</p>	50
	Maximum fluid viscosity (mm²/s)	25cSt
	Ambient temperature: with class F solenoid coil (°C)	-10 ... +55
	Mounting position	Indifferent
	Weight (g) with solenoid coil MI series	150
	Weight (g) with solenoid coil MG series	200



F3271 - 2-way solenoid valve N.O. stainless steel body, with G connection (ISO 228) - 1/8"

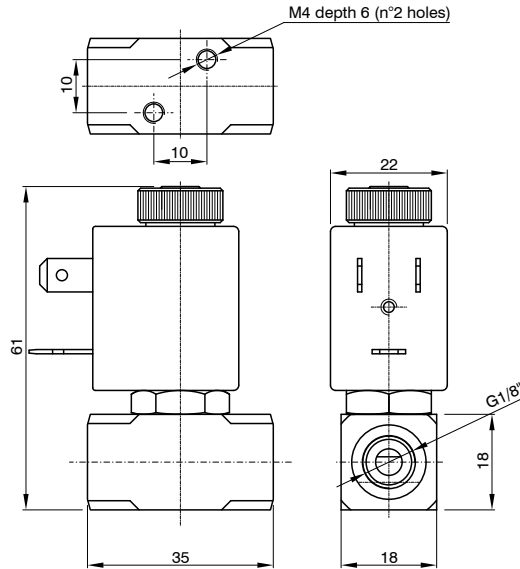

CODE "V" = FPM seals	G connection (ISO 228) ⊕ = Connection	Orifice (mm)	KV (m ³ /h)	Differential pressure (bar)			Power consumption			⊕ = Solenoid coil		Temperature range (°C)
	A			Min	Max		AC Inrush (VA)	AC Holding (VA)	DC (W)	Series	Size	
					AC	DC						
F3271⊕V12⊕	1/8"	1,2	0,04	0	19	19	12	8	6,5	MI	22	-10 ... +140
F3271⊕V15⊕		1,5	0,06		14	14						
F3271⊕V20⊕		2	0,09		8	8						
F3271⊕V25⊕		2,5	0,14		4,5	4,5						
F3271⊕V31⊕		3,1	0,19		2,5	2,5						

N.B. For use with steam maximum admitted pressure PS is 2,5 bar (relative pressure).

Example: F3271⊕V25⊕ => F3271AV25MI58:

2-way solenoid valve normally open, direct acting poppet type with G connection (ISO 228) 1/8", FPM seals, 2,5 mm orifice, solenoid coil 230 VAC (50-60 Hz) (MI58, size 22 for more information, please refer to the section "Solenoid coils - Series F300").

Pneumatic symbol

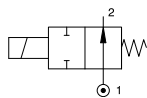

Diagram

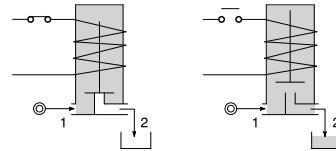

Construction characteristics	Technical characteristics	
<ul style="list-style-type: none"> - AISI 316 stainless steel body - AISI 316 stainless steel guide tube - AISI 430FR stainless steel mobile and fixed core - Silver advance ring - AISI 316 stainless steel springs - FPM sealing assemblies OPTIONS (on request): <ul style="list-style-type: none"> - For use with oxygen - XME solenoid coil for potentially explosive environments to ATEX standards - Ex mb IIC - certified solenoid coils - Versions for use with fluid temperature at -40 °C 	Maximum admitted pressure (bar)	50
	Maximum fluid viscosity (mm ² /s)	25cSt
	Ambient temperature: with class F solenoid coil (°C)	-10 ... +55
	Mounting position	Indifferent
	Weight (g)	150

F3210 - 2-way solenoid valve N.O. stainless steel body, with G connection (ISO 228) - 1/4" ... 1/2"

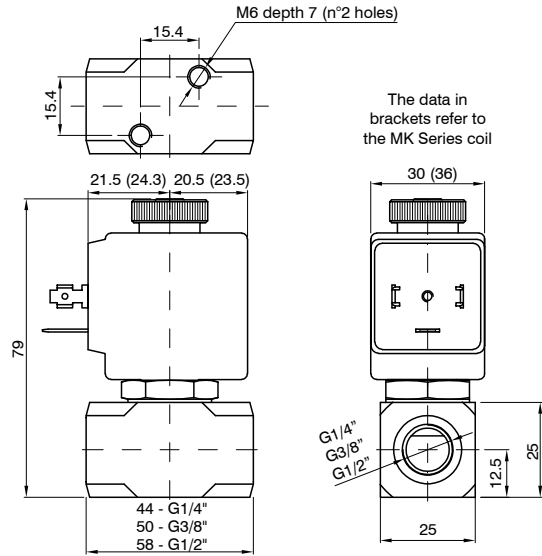

CODE "V" = FPM seals	G connection (ISO 228) ⊕ Connection			Orifice (mm)	KV (m³/h)	Differential pressure (bar)			Power consumption			⊕ = Solenoid coil		Temperature range (°C)	
	B	C	D			Min	Max		AC Inrush (VA)	AC Holding (VA)	DC (W)	Series	Size		
							AC	DC							
F3210⊕V15⊕	1/4"	3/8"	1/2"	1,5	0,07	0	/	/	/	/	MG/AC	30	-10 ... +140		
F3210⊕V20⊕				2	0,1									23	17
F3210⊕V25⊕				2,5	0,15									12	9
F3210⊕V30⊕				3	0,25									7	5,5
F3210⊕V35⊕				3,5	0,32									4,5	3
F3210⊕V40⊕				4	0,36									23	18
F3210⊕V45⊕				4,5	0,41									11	7
F3210⊕V52⊕				5,2	0,47									6,5	4
F3210⊕V15⊕	1/4"	3/8"	1/2"	1,5	0,07	0	/	/	/	10	MG/DC	30			
F3210⊕V20⊕				2	0,1									18	11
F3210⊕V25⊕				2,5	0,15									7	6,5
F3210⊕V30⊕				3	0,25									4	3,5
F3210⊕V35⊕				3,5	0,32									3	2,2
F3210⊕V40⊕				4	0,36									23	23
F3210⊕V45⊕				4,5	0,41									17	17
F3210⊕V52⊕				5,2	0,47									12	12
F3210⊕V15⊕	1/4"	3/8"	1/2"	1,5	0,07	0	/	/	/	27	MK (AC/DC)	36			
F3210⊕V20⊕				2	0,1									23	23
F3210⊕V25⊕				2,5	0,15									17	17
F3210⊕V30⊕				3	0,25									12	12
F3210⊕V35⊕				3,5	0,32									9	9
F3210⊕V40⊕				4	0,36									7	7
F3210⊕V45⊕				4,5	0,41									5,5	5,5
F3210⊕V52⊕				5,2	0,47									4,5	4,5
F3210⊕V64⊕				6,4	0,64	3	3	3,5	3,5						

N.B. For use with steam maximum admitted pressure PS is 2,5 bar (relative pressure).

Example: F3210⊕V25⊕ => F3210BV25MG5:

2-way solenoid valve normally open, direct acting poppet type with G connection (ISO 228) 1/4", FPM seals, 2,5 mm orifice, solenoid coil 24 VDC (MG5, size 30 for more information, please refer to the section "Solenoid coils - Series F300").

Pneumatic symbol

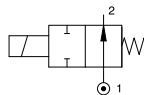

Diagram

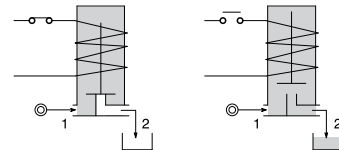

Construction characteristics

- AISI 303 stainless steel body
- AISI 303 stainless steel guide tube
- AISI 430FR stainless steel mobile and fixed core
- AISI 302 stainless steel springs
- FPM sealing assemblies

OPTIONS (on request):

- Silver advance ring
- For use with oxygen
- certified solenoid coils
- Versions for use with fluid temperature at -40 °C
- Manual override

Technical characteristics

Maximum admitted pressure (bar)	50
Maximum fluid viscosity (mm²/s)	25cSt
Ambient temperature: with class F solenoid coil (°C)	-10 ... +55
Ambient temperature: with class H solenoid coil (°C)	-10 ... +80
Mounting position	Indifferent
Weight (g) with solenoid coil MG series	300
Weight (g) with solenoid coil MK series	380



F3211 - 2-way solenoid valve N.O. stainless steel body, with G connection (ISO 228) - 1/8"

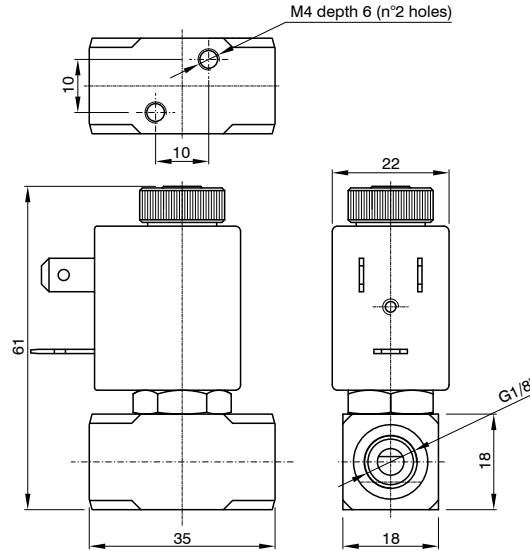

CODE "V" = FPM seals	G connection (ISO 228) ⊕ = Connection	Orifice (mm)	KV (m ² /h)	Differential pressure (bar)			Power consumption			⊕ = Solenoid coil		Temperature range (°C)
	A			Min	Max		AC Inrush (VA)	AC Holding (VA)	DC (W)	Series	Size	
					AC	DC						
F3211⊕V12⊕	1/8"	1,2	0,04	0	19	19	12	8	6,5	MI	22	-10 ... +140
F3211⊕V15⊕		1,5	0,06		14	14						
F3211⊕V20⊕		2	0,09		8	8						
F3211⊕V25⊕		2,5	0,14		4,5	4,5						
F3211⊕V31⊕		3,1	0,19		2,5	2,5						

N.B. For use with steam maximum admitted pressure PS is 2,5 bar (relative pressure).

Example: F3211⊕V25⊕ => F3211AV25MI58:

2-way solenoid valve normally open, direct acting poppet type with G connection (ISO 228) 1/8", FPM seals, 2,5 mm orifice, solenoid coil 230 VAC (50-60 Hz) (MI58, size 22 for more information, please refer to the section "Solenoid coils - Series F300").

Pneumatic symbol

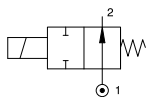

Diagram

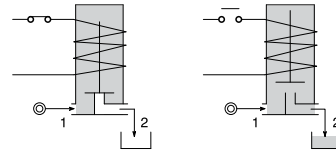

Construction characteristics	Technical characteristics	
- AISI 303 stainless steel body - AISI 303 stainless steel guide tube - AISI 430FR stainless steel mobile and fixed core - AISI 302 stainless steel springs - FPM sealing assemblies OPTIONS (on request): - XME solenoid coil for potentially explosive environments to ATEX standards - Ex mb IIC - For use with oxygen - certified solenoid coils - Versions for use with fluid temperature at -40 °C - Manual override	Maximum admitted pressure (bar)	50
	Maximum fluid viscosity (mm ² /s)	25cSt
	Ambient temperature: with class F solenoid coil (°C)	-10 ... +55
	Mounting position	Indifferent
	Weight (g)	150

F3206 - 2-way solenoid valve N.O. brass body, with G connection (ISO 228) - 1/8" and 1/4"

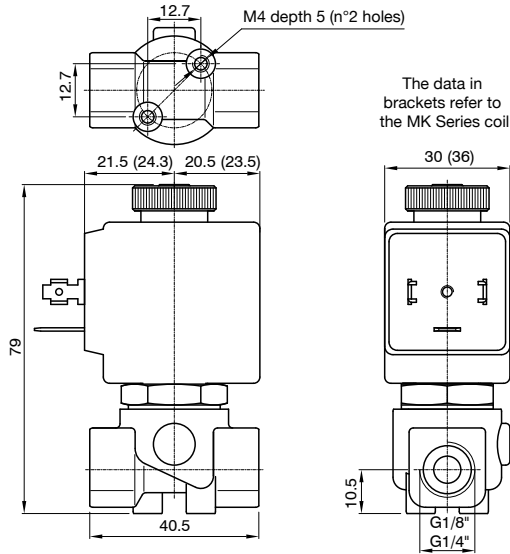

CODE "V" = FPM seals	G connection (ISO 228) ⊕ = Connection		Orifice (mm)	KV (m³/h)	Differential pressure (bar)			Power consumption			⊕ = Solenoid coil		Temperature range (°C)	
	A	B			Min	Max		AC Inrush (VA)	AC Holding (VA)	DC (W)	Series	Size		
						AC	DC							
F3206CV15B	1/8"	1/4"	1,5	0,07	0	/	20	15	/	MG/AC	30			
F3206CV20B			2	0,1									23	17
F3206CV25B			2,5	0,15									12	8
F3206CV30B			3	0,25									7	5,5
F3206CV35B			3,5	0,32									4,5	3
F3206CV40B			4	0,36									18	11
F3206CV45B			4,5	0,41									7	6,5
F3206CV52B			5,2	0,47									4	3,5
F3206CV52B			5,2	0,47									3	2,2
F3206CV15B	1/8"	1/4"	1,5	0,07	0	/	/	/	10	MG/DC	30	-10 ... +140		
F3206CV20B			2	0,1									23	23
F3206CV25B			2,5	0,15									17	17
F3206CV30B			3	0,25									12	12
F3206CV35B			3,5	0,32									8	8
F3206CV40B			4	0,36									7	7
F3206CV45B			4,5	0,41									5,5	5,5
F3206CV52B			5,2	0,47									4,5	4,5
F3206CV52B			5,2	0,47									3	3
F3206CV15B	1/8"	1/4"	1,5	0,07	0	/	/	/	27	MK (AC/DC)	36			
F3206CV20B			2	0,1									23	23
F3206CV25B			2,5	0,15									17	17
F3206CV30B			3	0,25									12	12
F3206CV35B			3,5	0,32									8	8
F3206CV40B			4	0,36									7	7
F3206CV45B			4,5	0,41									5,5	5,5
F3206CV52B			5,2	0,47									4,5	4,5
F3206CV64B			6,4	0,64									3,5	3,5

N.B. For use with steam maximum admitted pressure PS is 2,5 bar (relative pressure).

Example: F3206CV25B ⊕ => F3206BV25MG5:

2-way solenoid valve normally open, direct acting poppet type with G connection (ISO 228) 1/4", FPM seals, 2,5 mm orifice, solenoid coil 24 VDC (MG5, size 30 for more information, please refer to the section "Solenoid coils - Series F300").

Pneumatic symbol

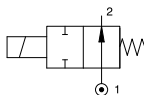

Diagram

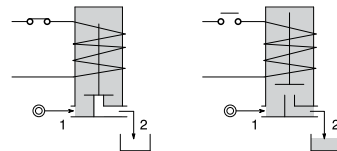

Construction characteristics

- Brass body
- Brass guide tube
- AISI 430FR stainless steel mobile and fixed core
- AISI 302 stainless steel springs
- FPM sealing assemblies

OPTIONS (on request):

- Stainless steel guide tube
- Chemical nickel plating surface treatment
- certified solenoid coils
- Versions for use with fluid temperature at -40 °C
- Manual override

Technical characteristics

Maximum admitted pressure (bar)	50
Maximum fluid viscosity (mm²/s)	25cSt
Ambient temperature: with class F solenoid coil (°C)	-10 ... +55
Ambient temperature: with class H solenoid coil (°C)	-10 ... +80
Mounting position	Indifferent
Weight (g) with solenoid coil MG series	300
Weight (g) with solenoid coil MK series	380



F3206 - 2-way solenoid valve N.O. brass body, with G connection (ISO 228) - 3/8" and 1/2"

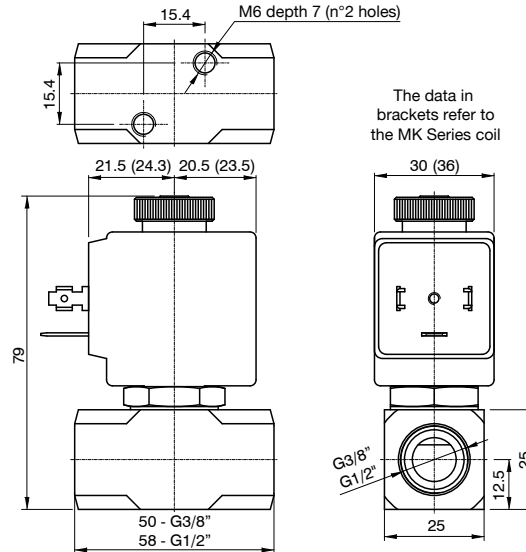

CODE "V" = FPM seals	G connection (ISO 228) ⊕ = Connection		Orifice (mm)	KV (m ² /h)	Differential pressure (bar)		Power consumption			⊕ = Solenoid coil		Temperature range (°C)	
	C	D			Min	Max		AC Inrush (VA)	AC Holding (VA)	DC (W)	Series		Size
						AC	DC						
F3206⊕V15⊕	3/8"	1/2"	1,5	0,07	0	23	/	20	15	/	MG/AC	30	
F3206⊕V20⊕			2	0,1		17							
F3206⊕V25⊕			2,5	0,15		12							
F3206⊕V30⊕			3	0,25		9							
F3206⊕V35⊕			3,5	0,32		7							
F3206⊕V40⊕			4	0,36		5,5							
F3206⊕V45⊕			4,5	0,41		4,5							
F3206⊕V52⊕			5,2	0,47		3							
F3206⊕V15⊕	3/8"	1/2"	1,5	0,07	0	18	/	/	10	MG/DC	30	-10 ... +140	
F3206⊕V20⊕			2	0,1		11							
F3206⊕V25⊕			2,5	0,15		7							
F3206⊕V30⊕			3	0,25		6,5							
F3206⊕V35⊕			3,5	0,32		4							
F3206⊕V40⊕			4	0,36		3,5							
F3206⊕V45⊕			4,5	0,41		3							
F3206⊕V52⊕			5,2	0,47		2,2							
F3206⊕V15⊕	3/8"	1/2"	1,5	0,07	0	23	/	/	27	MK (AC/DC)	36		
F3206⊕V20⊕			2	0,1		17							
F3206⊕V25⊕			2,5	0,15		12							
F3206⊕V30⊕			3	0,25		9							
F3206⊕V35⊕			3,5	0,32		7							
F3206⊕V40⊕			4	0,36		5,5							
F3206⊕V45⊕			4,5	0,41		4,5							
F3206⊕V52⊕			5,2	0,47		3							
F3206⊕V64⊕			6,4	0,64		3,5	3,5						

N.B. For use with steam maximum admitted pressure PS is 2,5 bar (relative pressure).

Example: F3206⊕V25⊕ => F3206DV25MG5:

2-way solenoid valve normally open, direct acting poppet type with G connection (ISO 228) 1/2", FPM seals, 2,5 mm orifice, solenoid coil 24 VDC (MG5, size 30 for more information, please refer to the section "Solenoid coils - Series F300").

Pneumatic symbol

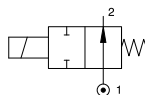

Diagram

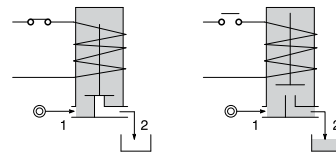

Construction characteristics

- Brass body
- Brass guide tube
- AISI 430FR stainless steel mobile and fixed core
- AISI 302 stainless steel springs
- FPM sealing assemblies

OPTIONS (on request):

- Stainless steel guide tube
- Chemical nickel plating surface treatment
- certified solenoid coils
- Versions for use with fluid temperature at -40 °C
- Manual override

Technical characteristics

Maximum admitted pressure (bar)	50
Maximum fluid viscosity (mm ² /s)	25cSt
Ambient temperature: with class F solenoid coil (°C)	-10 ... +55
Ambient temperature: with class H solenoid coil (°C)	-10 ... +80
Mounting position	Indifferent
Weight (g) with solenoid coil MG series	300
Weight (g) with solenoid coil MK series	380

F3305 - 3-way solenoid valve brass body, with G connection (ISO 228) - 1/8"

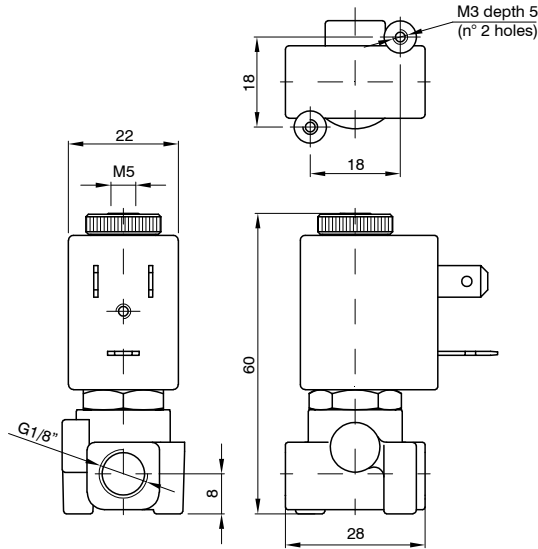

CODE "V" = FPM seals	G connection (ISO 228) ⊕ = Connection	Orifice (mm)		KV (m ³ /h)	Differential pressure (bar)			Power consumption			⊕ = Solenoid coil		Temperature range (°C)
		Inlet	Exhaust		Min	Max		AC Inrush (VA)	AC Holding (VA)	DC (W)	Series	Size	
N.C. - Normally closed													-10 ... +140
F3305CV12B	1/8"	1,2	1,5	0,04	0	15	15	12	8	6,5	MI	22	
F3305CV15B		1,5	1,5	0,06		10	10						
F3305CV20B		2	1,7	0,09		6	6						
N.O. - Normally open													
F3305CV15SB	1/8"	1,5	1,5	0,06	0	10	10	12	8	6,5	MI	22	
F3305CV17SB		1,7	2	0,07		6	6						
U - Universal													
F3305CV15UB	1/8"	1,5	1,5	0,06	0	6	6	12	8	6,5	MI	22	

N.B. For use with steam maximum admitted pressure PS is 2,5 bar (relative pressure).

Example: F3305CV12B => F3305AV12MI5:

3-way solenoid valve normally closed, direct acting poppet type with G connection (ISO 228) 1/8", FPM seals, 1,2 mm inlet orifice, solenoid coil 24 VDC (MI5, size 22 for more information, please refer to the section "Solenoid coils - Series F300").

Pneumatic symbol

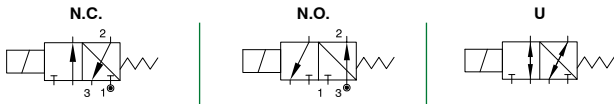

Diagram

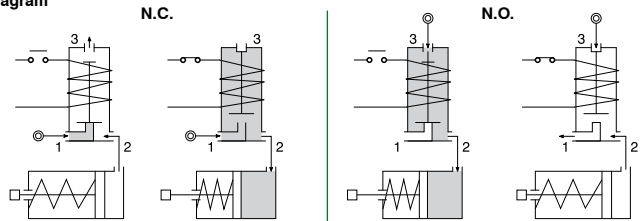

Construction characteristics

- Brass body
- Brass guide tube
- AISI 430FR stainless steel mobile and fixed core
- AISI 302 stainless steel springs
- FPM sealing assemblies

OPTIONS (on request):

- Stainless steel guide tube
- Chemical nickel plating surface treatment
- XME solenoid coil for potentially explosive environments to ATEX standards - Ex mb IIC
- CE certified solenoid coils
- Exhaust port with hositail connection
- Versions for use with fluid temperature at -40 °C
- Manual override

Technical characteristics

Maximum admitted pressure (bar)	50
Maximum fluid viscosity (mm ² /s)	25cSt
Ambient temperature: with class F solenoid coil (°C)	-10 ... +55
Mounting position	Universal
Weight (g)	110

F3306 - 3-way solenoid valve brass body, with G connection (ISO 228) - 1/8" and 1/4"

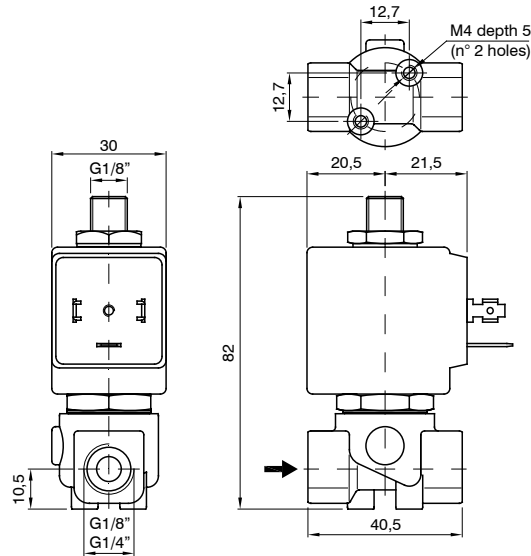

CODE "V" = FPM seals	G connection (ISO 228) ⊙ = Connection		Orifice (mm)		KV (m³/h)	Differential pressure (bar)			Power consumption			⊙ = Solenoid coil		Temperature range (°C)	
	A	B	Inlet	Exhaust		Min	Max		AC Inrush (VA)	AC Holding (VA)	DC (W)	Series	Size		
							AC	DC							
N.C. - Normally closed															
F3306⊙V15⊙	1/8"	1/4"	1,5	2,4	0,07	0	20	20	20	15	10	MG	30	-10 ... +140	
F3306⊙V20⊙			2	2,4	0,11		13	13							
F3306⊙V25⊙			2,5	2,4	0,16		10	10							
N.O. - Normally open															
F3306⊙V25S⊙	1/8"	1/4"	2,4	2,5	0,16	0	9	9	20	15	10	MG	30		-10 ... +140
F3306⊙V29S⊙			2,9	3	0,20		6,5	6,5							
U - Universal															
F3306⊙V25U⊙	1/8"	1/4"	2,5	2,4	0,16	0	5	4	20	15	10	MG	30	-10 ... +140	

N.B. For use with steam maximum admitted pressure PS is 2,5 bar (relative pressure).

Example: F3306⊙V15⊙ => F3306AV15MG5:

3-way solenoid valve normally closed, direct acting poppet type with G connection (ISO 228) 1/8", FPM seals, 1,5 mm inlet orifice, solenoid coil 24 VDC (MG5, size 30 for more information, please refer to the section "Solenoid coils - Series F300").

Pneumatic symbol

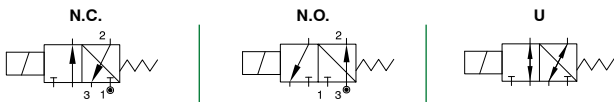

Diagram

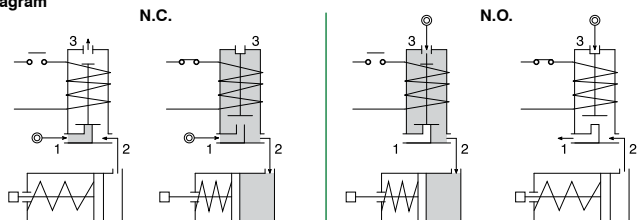

Construction characteristics	Technical characteristics	
<ul style="list-style-type: none"> - Brass body - AISI 303 stainless steel guide tube - AISI 430FR stainless steel mobile and fixed core - AISI 302 stainless steel springs - FPM sealing assemblies OPTIONS (on request): <ul style="list-style-type: none"> - Manual override - Chemical nickel plating surface treatment - is certified solenoid coils - Versions for use with fluid temperature at -40 °C 	Maximum admitted pressure (bar)	80
	Maximum fluid viscosity (mm²/s)	25cSt
	Ambient temperature: with class F solenoid coil (°C)	-10 ... +55
	Mounting position	Indifferent
	Weight (g)	125

F3310 - 3-way solenoid valve stainless steel body, with G connection (ISO 228) - 1/4"

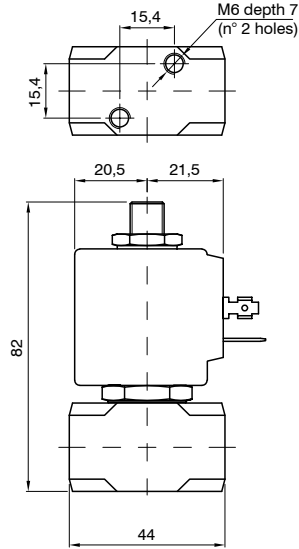
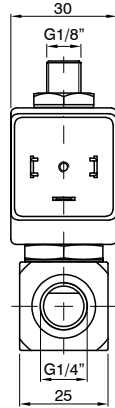

CODE "V" = FPM seals	G connection (ISO 228) ⊕ = Connection	Orifice (mm)		KV (m ³ /h)	Differential pressure (bar)			Power consumption			⊕ = Solenoid coil		Temperature range (°C)
		Inlet	Exhaust		Min	Max		AC Inrush (VA)	AC Holding (VA)	DC (W)	Series	Size	
N.C. - Normally closed													-10 ... +140
F3310⊕V20⊕	1/4"	2	2,4	0,11	0	13	13	20	15	10	MG	30	
F3310⊕V25⊕		2,5	2,4	0,16		10	10						
N.O. - Normally open													
F3310⊕V25S⊕	1/4"	2,4	2,5	0,16	0	9	9	20	15	10	MG	30	
F3310⊕V29S⊕		2,9	3	0,20		6,5	6,5						
U - Universal													
F3310⊕V25U⊕	1/4"	2,5	2,4	0,16	0	5	4	20	15	10	MG	30	

N.B. For use with steam maximum admitted pressure PS is 2,5 bar (relative pressure).

Example: F3310⊕V20⊕ => F3310BV20MG5:

3-way solenoid valve normally closed, direct acting poppet type with G connection (ISO 228) 1/4", FPM seals, 2 mm inlet orifice, solenoid coil 24 VDC (MG5, size 30 for more information, please refer to the section "Solenoid coils - Series F300").

Pneumatic symbol

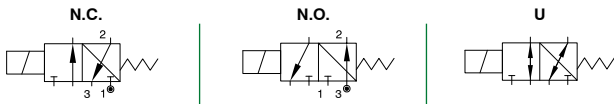

Diagram

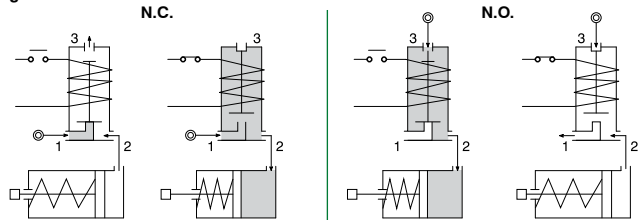

Construction characteristics

- AISI 303 stainless steel body
- AISI 303 stainless steel guide tube
- AISI 430FR stainless steel mobile and fixed core
- AISI 302 stainless steel springs
- FPM sealing assemblies

OPTIONS (on request):

- Silver advance ring
- certified solenoid coils
- Versions for use with fluid temperature at -40 °C

Technical characteristics

Maximum admitted pressure (bar)	80
Maximum fluid viscosity (mm ² /s)	25cSt
Ambient temperature: with class F solenoid coil (°C)	-10 ... +55
Mounting position	Indifferent
Weight (g)	360



F3311 - 3-way solenoid valve stainless steel body, with G connection (ISO 228) - 1/8"

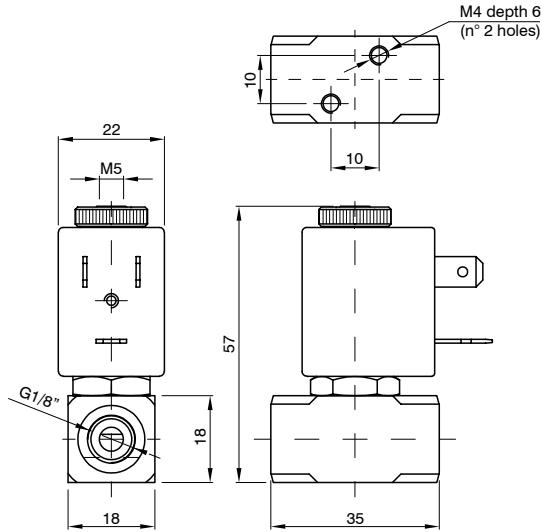

CODE "V" = FPM seals	G connection (ISO 228) ⊕ = Connection	Orifice (mm)		KV (m ³ /h)	Differential pressure (bar)			Power consumption			⊕ = Solenoid coil		Temperature range (°C)
		Inlet	Exhaust		Min	Max		AC Inrush (VA)	AC Holding (VA)	DC (W)	Series	Size	
						AC	DC						
N.C. - Normally closed													-10 ... +140
F3311⊕V12⊕	1/8"	1,2	1,5	0,04	0	15	15	12	8	6,5	MI	22	
F3311⊕V15⊕		1,5	1,5	0,06		10	10						
F3311⊕V20⊕		2	1,7	0,09		6	6						
N.O. - Normally open													
F3311⊕V15S⊕	1/8"	1,5	1,5	0,06	0	10	10	12	8	6,5	MI	22	
F3311⊕V17S⊕		1,7	2	0,07		6	6						
U - Universal													
F3311⊕V15U⊕	1/8"	1,5	1,5	0,06	0	6	6	12	8	6,5	MI	22	

N.B. For use with steam maximum admitted pressure PS is 2,5 bar (relative pressure).

Example: F3311⊕V20⊕ => F3311AV20MI58:

3-way solenoid valve normally closed, direct acting poppet type with G connection (ISO 228) 1/8", FPM seals, 2 mm inlet orifice, solenoid coil 230 VAC (50-60 Hz) (MI58, size 22 for more information, please refer to the section "Solenoid coils - Series F300").

Pneumatic symbol

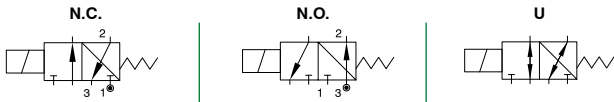

Diagram

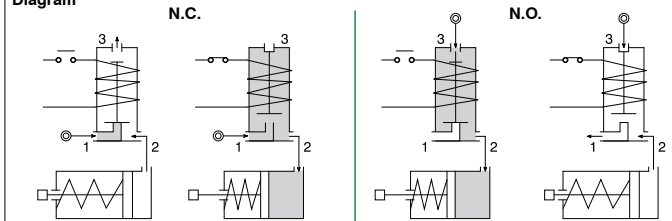

Construction characteristics	Technical characteristics	
<ul style="list-style-type: none"> - AISI 303 stainless steel body - AISI 303 stainless steel guide tube - AISI 430FR stainless steel mobile and fixed core - AISI 302 stainless steel springs - FPM sealing assemblies OPTIONS (on request): <ul style="list-style-type: none"> - Silver advance ring - certified solenoid coils - XME solenoid coil for potentially explosive environments to ATEX standards - Ex mb IIC - Exhaust port with hosedtail connection - Versions for use with fluid temperature at -40 °C 	Maximum admitted pressure (bar)	50
	Maximum fluid viscosity (mm ² /s)	25cSt
	Ambient temperature: with class F solenoid coil (°C)	-10 ... +55
	Mounting position	Indifferent
	Weight (g)	150

F332 - 3-way solenoid valve stainless steel or anodised aluminium body, with G connection (ISO 228) - 1/4"

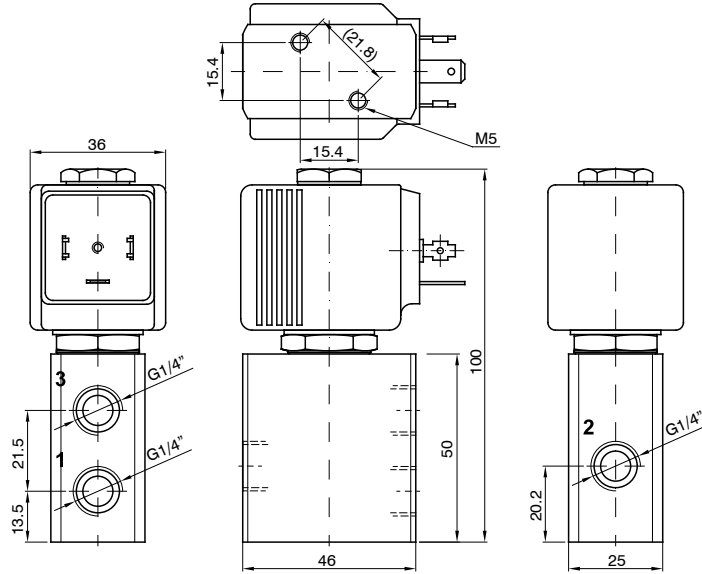

CODE "V" = FPM seals	G connection (ISO 228) ⊕ = Connection	Orifice (mm)		KV (m ³ /h)	Differential pressure (bar)			Power consumption			⊖ = Solenoid coil		Temperature range (°C)
		Inlet	Exhaust		Min	Max		AC Inrush (VA)	AC Holding (VA)	DC (W)	Series	Size	
Anodised aluminium body													-10 ... +140
U - Universal													
F3320⊕V75⊖	1/4"	7,5	7,5	0,64	0	5	5	40	30	27	MK	36	
N.C. - Normally closed													
F3321⊕V75⊖	1/4"	7,5	7,5	0,64	0	9	9	40	30	27	MK	36	
N.O. - Normally open													
F3322⊕V75⊖	1/4"	7,5	7,5	0,64	0	9	9	40	30	27	MK	36	
Stainless steel body													-10 ... +140
U - Universal													
F3323⊕V75⊖	1/4"	7,5	7,5	0,64	0	5	5	40	30	27	MK	36	
N.C. - Normally closed													
F3324⊕V75⊖	1/4"	7,5	7,5	0,64	0	9	9	40	30	27	MK	36	
N.O. - Normally open													
F3325⊕V75⊖	1/4"	7,5	7,5	0,64	0	9	9	40	30	27	MK	36	

Example: F3321⊕V75⊖ => F3321BV75MK5:

3-way solenoid valve normally closed, direct acting poppet type aluminium body with G connection (ISO 228) 1/4", FPM seals, 7,5 mm inlet orifice, solenoid coil 24 VDC (MK5, size 36 for more information, please refer to the section "Solenoid coils - Series F300").

Pneumatic symbol



Construction characteristics	Technical characteristics	
- AISI 303 stainless steel or anodised aluminium body	Maximum admitted pressure (bar)	50
- AISI 303 stainless steel guide tube	Maximum fluid viscosity (mm ² /s)	25cSt
- AISI 430FR stainless steel mobile and fixed core	Ambient temperature: with class H solenoid coil (°C)	-10 ... +80
- AISI 302 stainless steel springs	Mounting position	Indifferent
- FPM sealing assemblies	Weight (g)	430



F3371 - 3-way solenoid valve stainless steel body, with G connection (ISO 228) - 1/8"

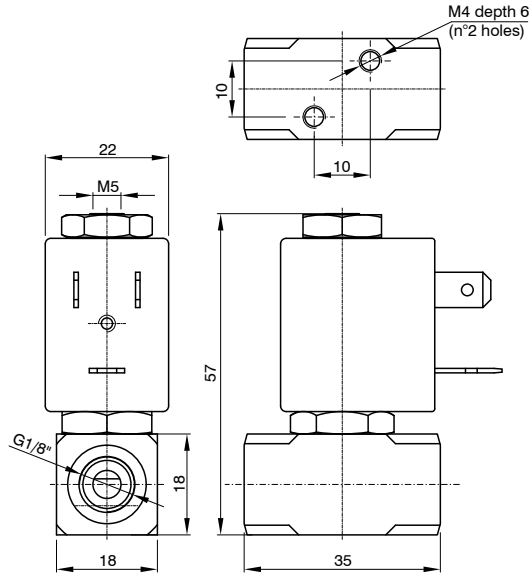

CODE "V" = FPM seals	G connection (ISO 228) ⊕ = Connection	Orifice (mm)		KV (m³/h)	Differential pressure (bar)			Power consumption			⊕ = Solenoid coil		Temperature range (°C)
		Inlet	Exhaust		Min	Max		AC Inrush (VA)	AC Holding (VA)	DC (W)	Series	Size	
						AC	DC						
N.C. - Normally closed													-10 ... +140
F3371⊕V12⊕	1/8"	1,2	1,5	0,04	0	15	15	12	8	6,5	MI	22	
F3371⊕V15⊕		1,5	1,5	0,06		10	10						
F3371⊕V20⊕		2	1,5	0,09		6	6						
N.O. - Normally open													
F3371⊕V15S⊕	1/8"	1,5	1,5	0,06	0	10	10	12	8	6,5	MI	22	
U - Universal													
F3371⊕V15U⊕	1/8"	1,5	1,5	0,06	0	6	6	12	8	6,5	MI	22	

N.B. For use with steam maximum admitted pressure PS is 2,5 bar (relative pressure).

Example: F3371⊕V12⊕ => F3371AV12MI58:

3-way solenoid valve normally closed, direct acting poppet type with G connection (ISO 228) 1/8", FPM seals, 1,2 mm inlet orifice, solenoid coil 230 VAC (50-60 Hz) (MI58, size 22 for more information, please refer to the section "Solenoid coils - Series F300").

Pneumatic symbol

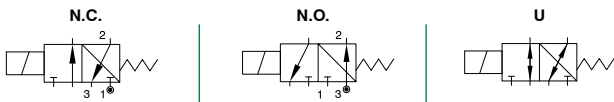

Diagram

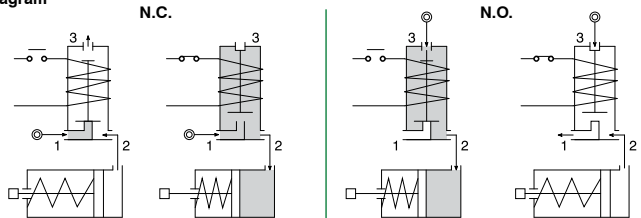

Construction characteristics

- AISI 316 stainless steel body
- AISI 316 stainless steel guide tube
- AISI 430FR stainless steel mobile and fixed core
- Silver advance ring
- AISI 316 stainless steel springs
- FPM sealing assemblies

OPTIONS (on request):

- XME solenoid coil for potentially explosive environments to ATEX standards - Ex mb IIC
- Exhaust port with hosetail connection
- certified solenoid coils
- Versions for use with fluid temperature at -40 °C

Technical characteristics

Maximum admitted pressure (bar)	50
Maximum fluid viscosity (mm²/s)	25cSt
Ambient temperature: with class F solenoid coil (°C)	-10 ... +55
Mounting position	Indifferent
Weight (g)	150

F3370 - 3-way solenoid valve stainless steel body, with G connection (ISO 228) - 1/4"

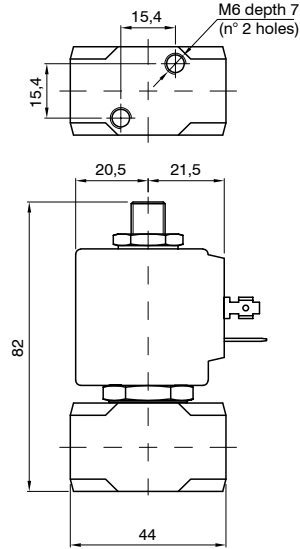
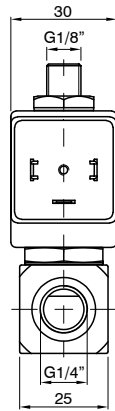

CODE "V" = FPM seals	G connection (ISO 228) ⊕ = Connection	Orifice (mm)		KV (m³/h)	Differential pressure (bar)			Power consumption			⊕ = Solenoid coil		Temperature range (°C)
		From 1 to 2	From 2 to 3		Min	Max		AC Inrush (VA)	AC Holding (VA)	DC (W)	Series	Size	
N.C. - Normally closed													-10 ... +140
F3370⊕V15⊕	1/4"	1,5	2,4	0,07	0	16	16	20	15	10	MG	30	
F3370⊕V20⊕		2	2,4	0,11		13	13						
F3370⊕V25⊕		2,5	2,4	0,16		10	10						
N.O. - Normally open													
F3370⊕V24S⊕	1/4"	2,4	2,5	0,16	0	9	9	20	15	10	MG	30	
U - Universal													
F3370⊕V25U⊕	1/4"	2,5	2,4	0,16	0	5	4	20	15	10	MG	30	

N.B. For use with steam maximum admitted pressure PS is 2,5 bar (relative pressure).

Example: F3370⊕V15⊕ => F3370BV15MG5:

3-way solenoid valve normally closed, direct acting poppet type with G connection (ISO 228) 1/4", FPM seals, 1,5 mm orifice, from 1 to 2, solenoid coil 24 VDC (MG5, size 30 for more information, please refer to the section "Solenoid coils - Series F300").

Pneumatic symbol

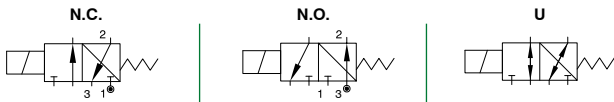

Diagram

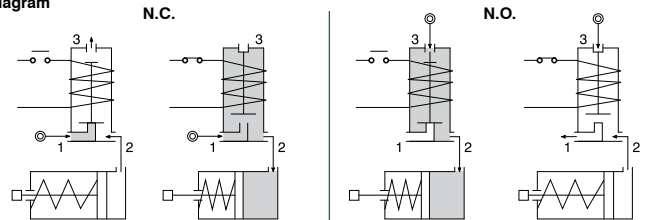

Construction characteristics

- AISI 316 stainless steel body
- AISI 316 stainless steel guide tube
- AISI 430FR stainless steel mobile and fixed core
- Silver advance ring
- AISI 316 stainless steel springs
- FPM sealing assemblies

OPTIONS (on request):

- For use with oxygen
- CE certified solenoid coils
- Versions for use with fluid temperature at -40 °C

Technical characteristics

Maximum admitted pressure (bar)	80
Maximum fluid viscosity (mm²/s)	25cSt
Ambient temperature: with class F solenoid coil (°C)	-10 ... +55
Mounting position	Indifferent
Weight (g)	360



**FX3370 - 3-way solenoid valve N.C. stainless steel body, with G connection (ISO 228)
with certified housing: Ex d IIC T6 or T5 or T4 Gb - 1/4"**

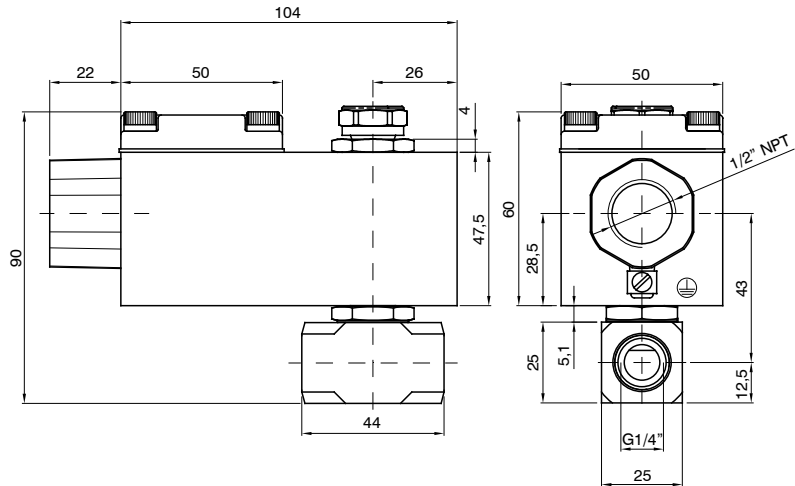

CODE "V" = FPM seals	G connection (ISO 228) ⊕ = Connection	Orifice (mm)		KV (m ³ /h)	Differential pressure (bar)			Power consumption		⊕ = Solenoid coil	Temperature range (°C)
		From 1 to 2	From 2 to 3		Min	Max		AC Holding (VA)	DC (W)		
						AC	DC				
FX3370⊕V15⊕	1/4"	1,5	2,4	0,07	0	16	16	12	8	A6B = 24 Volt (AC 50-60 Hz) A6E = 220/230 Volt (AC 50-60 Hz) A60 = 12 Volt (DC) A61 = 24 Volt (DC)	-10 ... +80
FX3370⊕V20⊕		2	2,4	0,11		13	13				
FX3370⊕V25⊕		2,5	2,4	0,16		10	10				

N.B. For use with steam maximum admitted pressure PS is 2,5 bar (relative pressure).

Example: FX3370⊕V15⊕ => FX3370BV15A60:

3-way solenoid valve normally closed, direct acting poppet type with certified housing: Ex d IIC T6 or T5 or T4 Gb, with G connection (ISO 228) 1/4", FPM seals, 1,5 mm orifice, from 1 to 2, solenoid coil 12 VDC (A60).

Pneumatic symbol

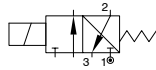

Diagram

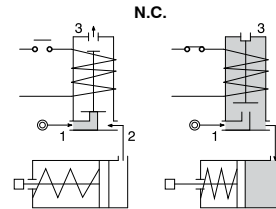

Construction characteristics	Technical characteristics	
- AISI 316 stainless steel body	Maximum admitted pressure (bar)	80
- AISI 316 stainless steel guide tube	Maximum fluid viscosity (mm ² /s)	25cSt
- AISI 430FR stainless steel mobile and fixed core	Ambient temperature (°C)	-40 ... +60
- AISI 316 stainless steel springs	Mounting position	Vertical with solenoid coil upwards
- Red light alloy housing	Weight (g)	650
- 1/2" NPT electrical connection (M20x1,5 on request)		
- FPM sealing assemblies		

F3107 - 2-way solenoid valve N.C. brass body and cover, with G connection (ISO 228) - 1/4" ... 1" 1/4

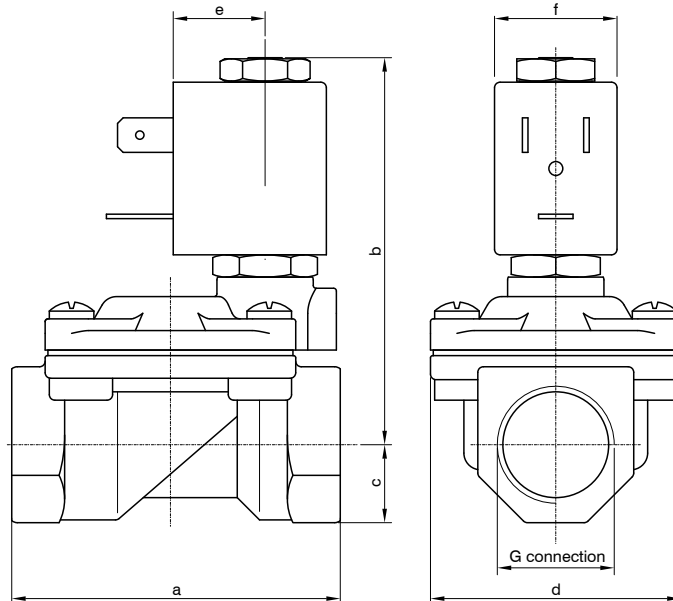

CODE "V" = FPM seals	G connection (ISO 228) ⊕ Connection						Orifice (mm)	KV (m ³ /h)	Differential pressure (bar)			Power consumption			⊕ = Solenoid coil		Temperature range (°C)
	B	C	D	E	F	G			Min	Max		AC Inrush (VA)	AC Holding (VA)	DC (W)	Series	Size	
										AC	DC						
F3107⊕V10⊕	1/4"	/					10	1,5	0,15	15	15	12	8	6,5	MI	22	-10 ... +140
F3107⊕V10⊕	/	3/8"	/				10	1,7		15	15						
F3107⊕V12⊕	/	3/8"	/				12	2,2		15	15						
F3107⊕V12⊕	/	1/2"	/		/		12	2,5		15	15						
F3107⊕V18⊕	/	3/4"		/		18	5,5	13		13							
F3107⊕V25⊕	/	1"		/		25	10,2	10		10							
F3107⊕V30⊕	/	1" 1/4		/		30	15	10	10								

G connection	1/4" Ø10	3/8" Ø10	3/8" Ø12	1/2" Ø12	3/4"	1"	1" 1/4 Ø30
a	49	49	59	59	79	96	119
b	65	65	70	70	76	85	92
c	11	11	14	14	18	20	25
d	32	32	45	45	55	72	85
e	16						
f	22						
Weight (g)	230	240	420	390	650	1050	1700

N.B. For use with steam maximum admitted pressure PS is 2,5 bar (relative pressure).

Example: F3107⊕V25⊕ => F3107FV25MI58:

2-way solenoid valve normally closed, servo-assisted diaphragm with G connection (ISO 228) 1", FPM seals, 25 mm orifice, solenoid coil 230 VAC (50-60 Hz) (MI58, size 22 for more information, please refer to the section "Solenoid coils - Series F300").

Pneumatic symbol

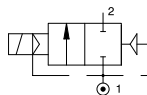

Diagram

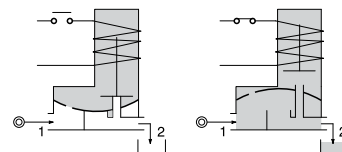

Construction characteristics	Technical characteristics								
<ul style="list-style-type: none"> - Brass body and cover - AISI 303 stainless steel guide tube - AISI 430FR stainless steel mobile and fixed core - AISI 302 stainless steel springs - FPM sealing assemblies <p>OPTIONS (on request):</p> <ul style="list-style-type: none"> - Manual override - Chemical nickel plating surface treatment - Version with slowed commutation - Version for vacuum (air/gas) - For use with oxygen - XME solenoid coil for potentially explosive environments to ATEX standards - Ex mb IIC - certified solenoid coils 	<table border="1"> <tr> <td>Maximum admitted pressure (bar)</td> <td>25</td> </tr> <tr> <td>Minimum differential pressure (bar)</td> <td>0,15</td> </tr> <tr> <td>Maximum fluid viscosity (mm²/s)</td> <td>25cSt</td> </tr> <tr> <td>Ambient temperature: with class F solenoid coil (°C)</td> <td>-10 ... +55</td> </tr> </table>	Maximum admitted pressure (bar)	25	Minimum differential pressure (bar)	0,15	Maximum fluid viscosity (mm ² /s)	25cSt	Ambient temperature: with class F solenoid coil (°C)	-10 ... +55
Maximum admitted pressure (bar)	25								
Minimum differential pressure (bar)	0,15								
Maximum fluid viscosity (mm ² /s)	25cSt								
Ambient temperature: with class F solenoid coil (°C)	-10 ... +55								
	Mounting position	Preferably with solenoid coil upwards							



**FX3107 - 2-way solenoid valve N.C. brass body and cover, with G connection (ISO 228)
with certified housing: Ex d IIC T6 or T5 or T4 Gb - 1/4" ... 3"**

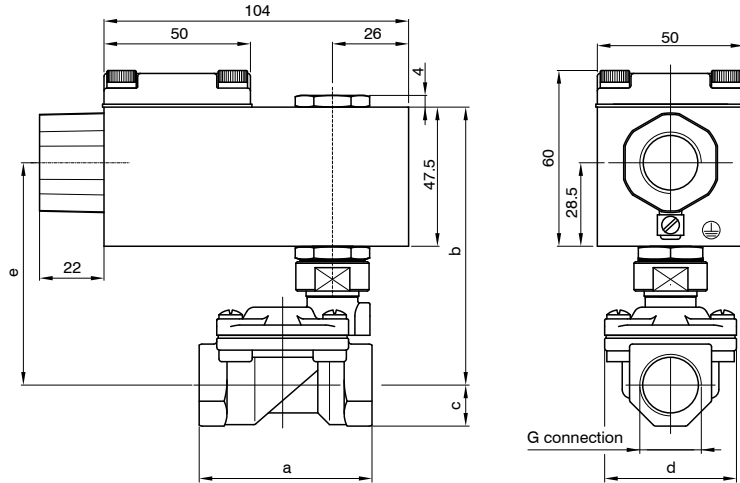

CODE "V" = FPM seals "B" = NBR seals	G connection (ISO 228) ⊕ = Connection											Orifice (mm)	KV (m³/h)	Differential pressure (bar)			Power consumption		⊕ = Solenoid coil	Temperature range (°C)
	B	C	D	E	F	G	H	I	M	R	Min			Max		AC Holding (VA)	DC (W)			
	AC		DC																	
FX3107⊕V10⊕	1/4"					/						10	1,5	0,15	15	15	12	8	A6B= 24 Volt (AC 50-60 Hz) A6E= 220/230 Volt (AC 50-60 Hz) A60= 12 Volt (DC) A61= 24 Volt (DC)	-10 ... +80
FX3107⊕V10⊕	/	3/8"				/					10	1,7	15		15					
FX3107⊕V12⊕	/	3/8"				/					12	2,2	15		15					
FX3107⊕V12⊕	/	1/2"				/					12	2,5	15		15					
FX3107⊕V18⊕	/	3/4"				/					18	5,5	13		13					
FX3107⊕V25⊕	/		1"			/					25	10,2	10		10					
FX3107⊕V30⊕	/			1" 1/4		/					30	15	10		10					
FX3107⊕V37⊕	/			1" 1/4		/					37	18	10		10					
FX3107⊕V37⊕	/				1" 1/2	/					37	21	10		10					
FX3107⊕V50⊕	/						2"				50	36	10		10					
FX3107⊕B75⊕	/							2" 1/2	/		75	75	0,3	5	5					
FX3107⊕B75⊕	/								3"		75	84		5	5					

G connection	1/4" Ø10	3/8" Ø10	3/8" Ø12	1/2" Ø12	3/4"	1"	1" 1/4 Ø30	1" 1/4	1" 1/2	2"	2" 1/2	3"
a	49	49	59	59	79	96	119	142	142	158	226	226
b	90	90	95	95	101	110	118	110	110	119	138	138
c	11	11	14	14	18	20	25	28	28	35	51	51
d	32	32	45	45	54	72	85	102	102	119	169	169
e	71	71	76	76	82	91	99	91	91	100	119	119
Weight (g)	720	720	920	920	1100	1500	2270	3330	3120	4720	10400	10000

N.B. The solenoid valve is suited for intercepting only fluids that are NOT potentially explosive.

Example: FX3107⊕V10⊕ => FX3107BV10A60:

2-way solenoid valve normally closed, servo-assisted diaphragm with certified housing: Ex d IIC T6 or T5 or T4 Gb, with G connection (ISO 228) 1/4", FPM seals, 10 mm orifice, solenoid coil 12 VDC (A60).

Pneumatic symbol

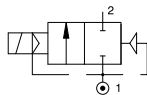

Diagram

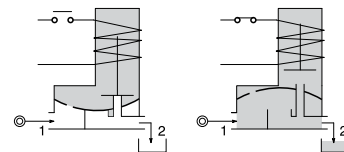

Construction characteristics	Technical characteristics	
- Brass body and cover - Red light alloy housing - 1/2" NPT electrical connection (M20x1,5 on request) - FPM sealing assemblies (NBR only for "M" and "R" versions)	Maximum admitted pressure (bar)	25
OPTIONS (on request): - Chemical nickel plating surface treatment - Version with slowed commutation	Minimum differential pressure (bar)	0,15 ... 0,3
	Maximum fluid viscosity (mm²/s)	25cSt
	Ambient temperature (°C)	-40 ... +60
	Mounting position	Vertical with solenoid coil upwards

F3177 - 2-way solenoid valve N.C. stainless steel body and cover, with G connection (ISO 228) - 3/8" ... 1"

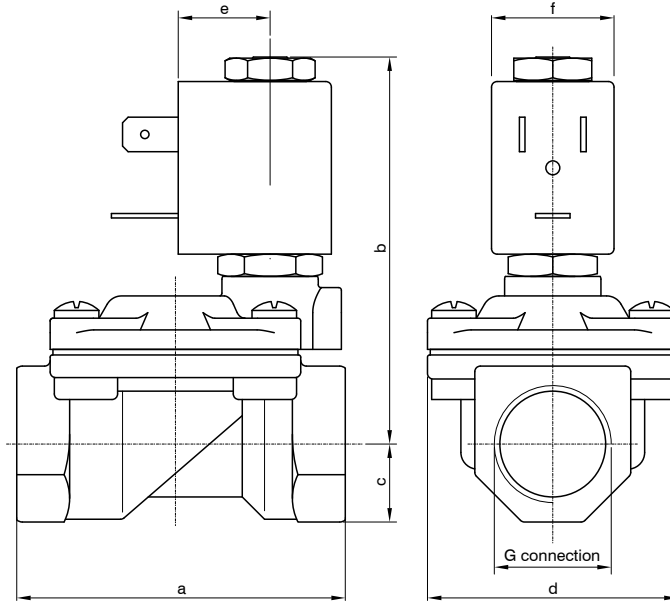

CODE "V" = FPM seals	G connection (ISO 228) ⊕ = Connection				Orifice (mm)	KV (m ³ /h)	Differential pressure (bar)			Power consumption			⊕ = Solenoid coil		Temperature range (°C)
	C	D	E	F			Min	Max		AC Inrush (VA)	AC Holding (VA)	DC (W)	Series	Size	
								AC	DC						
F3177CV12⊕	3/8"	/	/	/	12	2,2	0,15	15	15	12	8	6,5	MI	22	-10 ... +140
F3177CV12⊕	/	1/2"	/	/	12	2,5		15	15						
F3177CV18⊕	/	/	3/4"	/	18	5,5		13	13						
F3177CV25⊕	/	/	/	1"	25	10,2		10	10						

G connection	3/8"	1/2"	3/4"	1"
a	59	59	79	96
b	70	70	76	85
c	11	13	18	20
d	45	45	55	72
e	16			
f	22			
Weight (g)	300	320	550	950

N.B. For use with steam maximum admitted pressure PS is 2,5 bar (relative pressure).

Example: F3177CV12⊕ => F3177CV12MI58:

2-way solenoid valve normally closed, servo-assisted diaphragm with G connection (ISO 228) 3/8", FPM seals, 12 mm orifice, solenoid coil 230 VAC (50-60 Hz) (MI58, size 22 for more information, please refer to the section "Solenoid coils - Series F300").

Pneumatic symbol

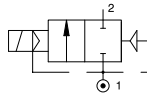

Diagram

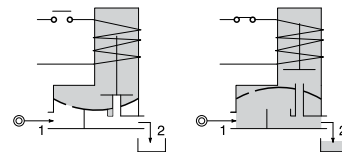

Construction characteristics	Technical characteristics	
<ul style="list-style-type: none"> - AISI 316 stainless steel body and cover - AISI 303 stainless steel guide tube - AISI 430FR stainless steel mobile and fixed core - AISI 302 stainless steel springs - FPM sealing assemblies OPTIONS (on request): <ul style="list-style-type: none"> - Manual override - Seals for use with foodstuff fluids - Version with slowed commutation - Silver advance ring - For use with oxygen - XME solenoid coil for potentially explosive environments to ATEX standards - Ex mb IIC - certified solenoid coils 	Maximum admitted pressure (bar)	25
	Minimum differential pressure (bar)	0,15
	Maximum fluid viscosity (mm ² /s)	25cSt
	Ambient temperature: with class F solenoid coil (°C)	-10 ... +55
Mounting position	Preferably with solenoid coil upwards	



**FX3177 - 2-way solenoid valve N.C. stainless steel body and cover, with G connection (ISO 228)
with certified housing: Ex d IIC T6 or T5 or T4 Gb - 3/8" ... 1"**

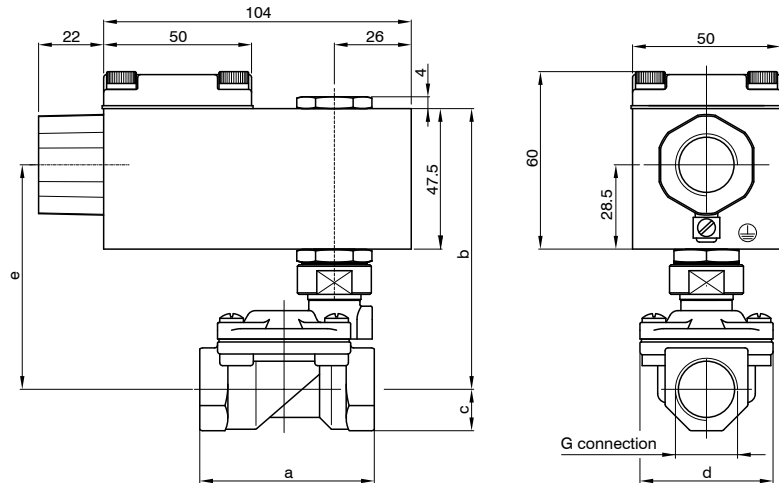

CODE "V" = FPM seals	G connection (ISO 228) ⊕ = Connection				Orifice (mm)	KV (m³/h)	Differential pressure (bar)				⊖ = Solenoid coil	Temperature range (°C)	
	C	D	E	F			Min	Max		AC Holding (VA)			DC (W)
FX3177⊕V121⊖	3/8"	/	/	/	12	2,2		0,15	15		15	12	
FX3177⊕V121⊖	/	1/2"	/	/	12	2,5	15		15				
FX3177⊕V181⊖	/	/	3/4"	/	18	5,5	13		13				
FX3177⊕V251⊖	/	/	/	1"	25	10,2	10		10				

G connection	3/8" Ø12	1/2" Ø12	3/4"	1"
a	59	59	79	96
b	95	95	101	110
c	14	14	18	20
d	45	45	54	72
e	76	76	82	91
Weight (g)	1120	1110	1100	1500

N.B. The solenoid valve is suited for intercepting only fluids that are NOT potentially explosive.

Example: FX3177⊕V12⊖ => FX3177CV12A60:

2-way solenoid valve normally closed, servo-assisted diaphragm with certified housing: Ex d IIC T6 or T5 or T4 Gb, with G connection (ISO 228) 3/8", FPM seals, 12 mm orifice, solenoid coil 12 VDC (A60).

Pneumatic symbol

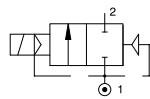

Diagram

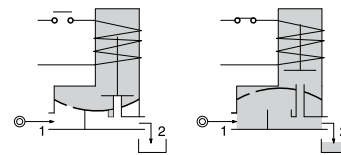

Construction characteristics	Technical characteristics	
- AISI 316 stainless steel body and cover	Maximum admitted pressure (bar)	25
- Red light alloy housing	Minimum differential pressure (bar)	0,15
- 1/2" NPT electrical connection (M20x1,5 on request)	Maximum fluid viscosity (mm²/s)	25cSt
- FPM sealing assemblies	Ambient temperature (°C)	-40 ... +60
OPTIONS (on request):	Mounting position	Vertical with solenoid coil upwards
- Version with slowed commutation		

F3277 - 2-way solenoid valve N.O. stainless steel body and cover, with G connection (ISO 228) - 3/8" ... 1"

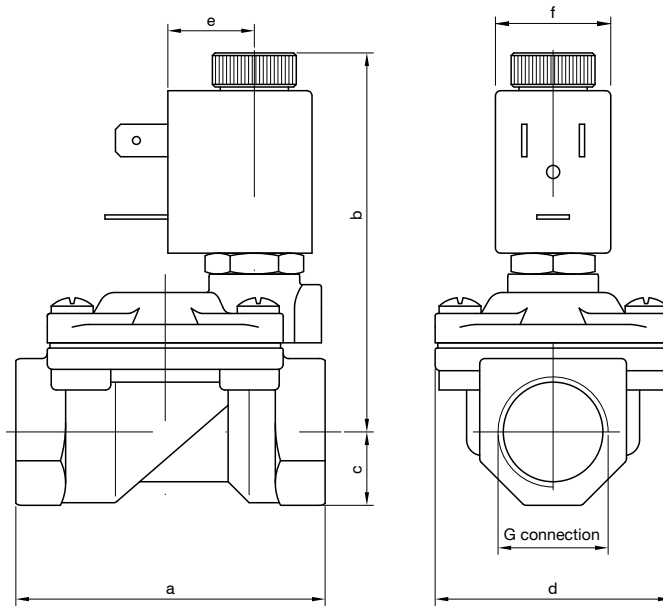

CODE "V" = FPM seals	G connection (ISO 228) ⊕ = Connection				Orifice (mm)	KV (m³/h)	Differential pressure (bar)		Power consumption			⊕ = Solenoid coil		Temperature range (°C)	
	C	D	E	F			Min	Max		AC Inrush (VA)	AC Holding (VA)	DC (W)	Series		Size
								AC	DC						
F3277CV12⊕	3/8"		/		12	2,2	0,15	15	15	12	8	6,5	MI	22	-10 ... +140
F3277CV12⊕	/	1/2"	/		12	2,5		15	15						
F3277CV18⊕	/	/	3/4"	/	18	5,5		13	13						
F3277CV25⊕	/	/	/	1"	25	10,2		10	10						

G connection	3/8"	1/2"	3/4"	1"
a	59	59	79	96
b	73	73	76	85
c	14	14	18	20
d	45	45	55	72
e	16			
f	22			
Weight (g)	300	320	550	950

N.B. For use with steam maximum admitted pressure PS is 2,5 bar (relative pressure).

Example: F3277CV12⊕ => F3277CV12MI58:

2-way solenoid valve normally open, servo-assisted diaphragm, with G connection (ISO 228) 3/8", FPM seals, 12 mm orifice, solenoid coil 230 VAC (50-60 Hz) (MI58, size 22 for more information, please refer to the section "Solenoid coils - Series F300").

Pneumatic symbol

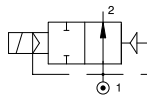

Diagram

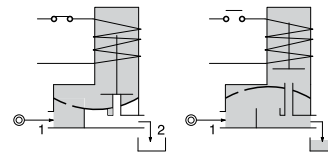

Construction characteristics	Technical characteristics	
<ul style="list-style-type: none"> - AISI 316 stainless steel body and cover - AISI 303 stainless steel guide tube - AISI 430FR stainless steel mobile and fixed core - AISI 302 stainless steel springs - FPM sealing assemblies OPTIONS (on request): <ul style="list-style-type: none"> - Seals for use with foodstuff fluids - Version with slowed commutation - Silver advance ring - For use with oxygen - XME solenoid coil for potentially explosive environments to ATEX standards - Ex mb IIC - certified solenoid coils 	Maximum admitted pressure (bar)	25
	Minimum differential pressure (bar)	0,15
	Maximum fluid viscosity (mm²/s)	25cSt
	Ambient temperature: with class F solenoid coil (°C)	-10 ... +55
	Mounting position	Preferably with solenoid coil upwards



F3207 - 2-way solenoid valve N.O. brass body and cover, with G connection (ISO 228) - 1/4" ... 1" 1/4

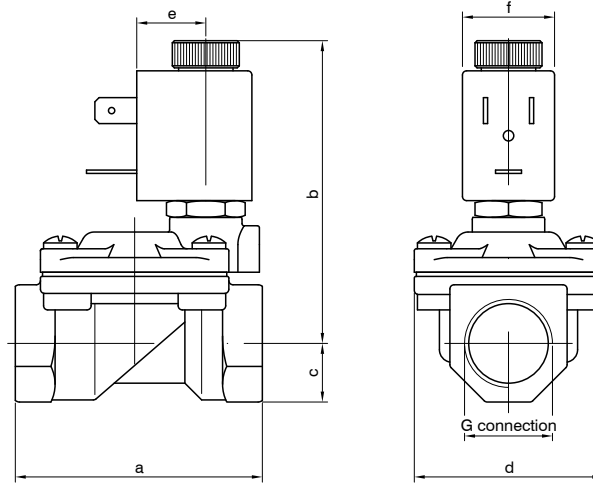

CODE "V" = FPM seals	G connection (ISO 228) ⊕ = Connection						Orifice (mm)	KV (m³/h)	Differential pressure (bar)			Power consumption			⊕ = Solenoid coil		Temperature range (°C)
	B	C	D	E	F	G			Min	Max		AC Inrush (VA)	AC Holding (VA)	DC (W)	Series	Size	
										AC	DC						
F3207⊕V10⊕	1/4"		/				10	1,5	0,15	15	15	12	8	6,5	MI	22	-10 ... +140
F3207⊕V10⊕	/	3/8"		/			10	1,7		15	15						
F3207⊕V12⊕	/	3/8"		/			12	2,2		15	15						
F3207⊕V12⊕	/		1/2"		/		12	2,5		15	15						
F3207⊕V18⊕	/			3/4"	/		18	5,5		13	13						
F3207⊕V25⊕	/				1"	/	25	10,2		10	10						
F3207⊕V30⊕	/					1" 1/4	30	15		10	10						

G connection	1/4" Ø10	3/8" Ø10	3/8" Ø12	1/2" Ø12	3/4"	1"	1" 1/4 Ø30
a	49	49	59	59	79	96	119
b	65	65	73	73	76	85	96
c	11	11	14	14	18	20	25
d	32	32	45	45	55	72	85
e	16						
f	22						
Weight (g)	230	240	420	390	650	1050	1700

N.B. For use with steam maximum admitted pressure PS is 2,5 bar (relative pressure).

Example: F3207⊕V10⊕ => F3207CV10MI58:

2-way solenoid valve normally open, servo-assisted diaphragm, with G connection (ISO 228) 1/4", FPM seals, 10 mm orifice, solenoid coil 230 VAC (50-60 Hz) (MI58, size 22 for more information, please refer to the section "Solenoid coils - Series F300").

Pneumatic symbol

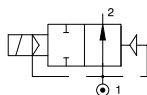

Diagram

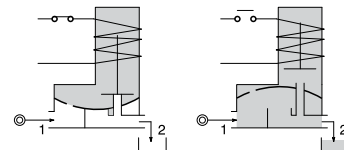

Construction characteristics	Technical characteristics	
<ul style="list-style-type: none"> - Brass body and cover - AISI 303 stainless steel guide tube - AISI 430FR stainless steel mobile and fixed core - AISI 302 stainless steel springs - FPM sealing assemblies OPTIONS (on request): <ul style="list-style-type: none"> - Manual override - Chemical nickel plating surface treatment - XME solenoid coil for potentially explosive environments to ATEX standards - Ex mb IIC - certified solenoid coils 	Maximum admitted pressure (bar)	25
	Minimum differential pressure (bar)	0,15
	Maximum fluid viscosity (mm²/s)	25cSt
	Ambient temperature: with class F solenoid coil (°C)	-10 ... +55
	Mounting position	Preferably with solenoid coil upwards

F3207 - 2-way solenoid valve N.O. brass body and cover, with G connection (ISO 228) - 1" 1/4 ... 3"

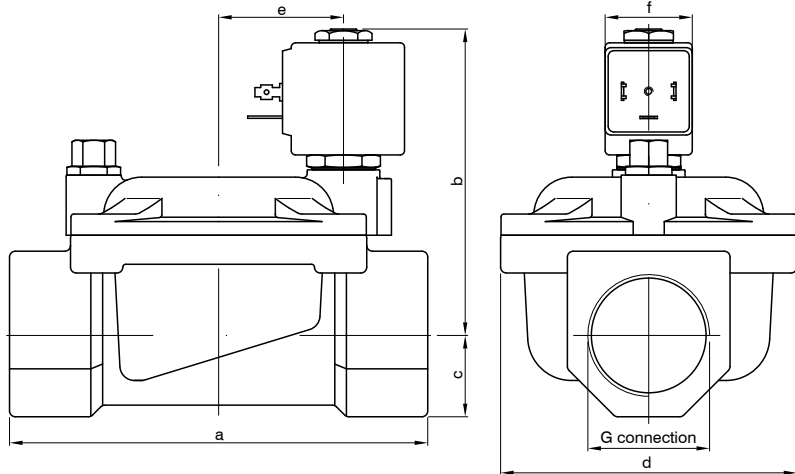

CODE "V" = FPM seals "B" = NBR seals	G connection (ISO 228) ⊕ = Connection					Orifice (mm)	KV (m ³ /h)	Differential pressure (bar)			Power consumption			⊕ = Solenoid coil		Temperature range (°C)
	G	H	I	M	R			Min	Max		AC Inrush (VA)	AC Holding (VA)	DC (W)	Series	Size	
									AC	DC						
F3207⊕V37⊕	1" 1/4		/			37	18	0,15	10	10	20	15	10	MG	30	-10 ... +140
F3207⊕V37⊕	/	1" 1/2		/		37	21		10	10						
F3207⊕V50⊕	/		2"			50	36		10	10						
F3207⊕B75⊕		/		2" 1/2	/	75	75	0,3	5	5	20	15	10	MG	30	-10 ... +90
F3207⊕B75⊕		/			3"	75	84		5	5						

G connection	1" 1/4	1" 1/2	2"	2" 1/2	3"
a	142	142	158	226	226
b	105	105	115	134	134
c	28	28	35	51	51
d	102	102	119	169	169
e	21				
f	30				
Weight (g)	3000	2850	4300	1170	9900

N.B. For use with steam maximum admitted pressure PS is 2,5 bar (relative pressure).

Example: F3107⊕V37⊕ => F3107GV37MG5:

2-way solenoid valve normally closed, servo-assisted diaphragm with G connection (ISO 228) 1" 1/4, FPM seals, 37 mm orifice, solenoid coil 24 VDC (MG5, size 30 for more information, please refer to the section "Solenoid coils - Series F300").

Pneumatic symbol

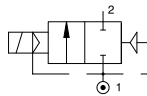

Diagram

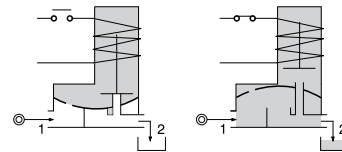

Construction characteristics

- Brass body and cover
- AISI 303 stainless steel guide tube
- AISI 430FR stainless steel mobile and fixed core
- AISI 302 stainless steel springs
- FPM sealing assemblies (NBR only for "M" and "R" versions)

OPTIONS (on request):

- Manual override
- Chemical nickel plating
- Version for vacuum (air/gas)
- certified solenoid coils

Technical characteristics

Maximum admitted pressure (bar)	20
Minimum differential pressure (bar)	0,15 ... 3
Maximum fluid viscosity (mm ² /s)	25cSt
Ambient temperature: with class F solenoid coil (°C)	-10 ... +55
Mounting position	Preferably with solenoid coil upwards



F3108 - 2-way solenoid valve N.C. brass body and cover, with G connection (ISO 228) - 3/8" ... 1"

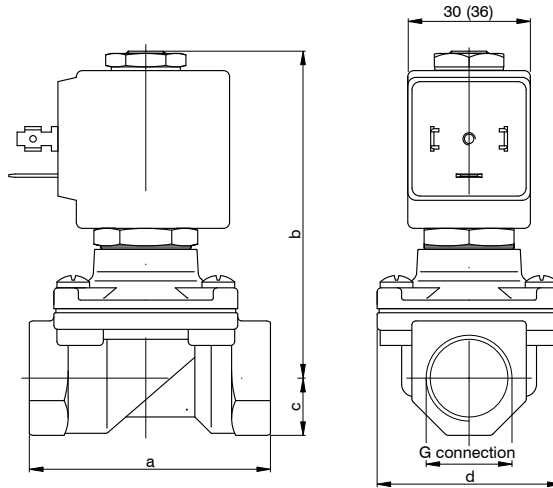

The data in brackets refer to the MK Series coil

CODE "V" = FPM seals	G connection (ISO 228) ⊕ = Connection				Orifice (mm)	KV (m³/h)	Differential pressure (bar)		Power consumption			⊕ = Solenoid coil		Temperature range (°C)	
	C	D	E	F			Min	Max	AC Inrush (VA)	AC Holding (VA)	DC (W)	Series	Size		
F3108⊕V12⊕	3/8"	/	/	/	12	2	0	10	/	20	15	/	MG/AC	30	-10 ... +140
F3108⊕V12⊕	/	1/2"	/	/	12	2,2		10	/						
F3108⊕V12⊕	3/8"	/	/	/	12	2		12	10	40	30	27	MK (AC/DC)		
F3108⊕V12⊕	/	1/2"	/	/	12	2,2		12	10						
F3108⊕V18⊕	/	/	3/4"	/	18	4,5		9	/	40	30	/	MK/DC		
F3108⊕V25⊕	/	/	/	1"	25	8,5		7	/						
F3108⊕V18C⊕	/	/	3/4"	/	18	4,5		/	9	/	/	27			
F3108⊕V25C⊕	/	/	/	1"	25	8,5		/	8	/	/				

G connection		3/8"	1/2"	3/4"	1"
a		59	59	79	96
b		83	83	90	101
c		14	14	18	20
d		45	45	55	72
Weight (g)	MG	520	490	/	/
	MK	600	570	810	1220

N.B. For use with steam maximum admitted pressure PS is 2,5 bar (relative pressure).

Example: F3108⊕V12⊕ => F3108CV12MG5:

2-way solenoid valve normally closed, with assisted-lift diaphragm with G connection (ISO 228) 3/8", FPM seals, 12 mm orifice, solenoid coil 24 VDC (MG5, size 30 for more information, please refer to the section "Solenoid coils - Series F300").

Pneumatic symbol

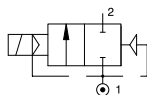

Diagram

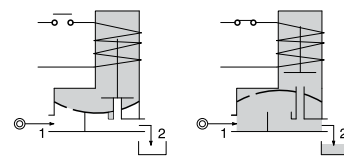

Construction characteristics	Technical characteristics	
<ul style="list-style-type: none"> - Brass body and cover - AISI 303 stainless steel guide tube - AISI 430FR stainless steel mobile and fixed core - AISI 302 stainless steel springs - FPM sealing assemblies OPTIONS (on request): <ul style="list-style-type: none"> - Chemical nickel plating - certified solenoid coils 	Maximum admitted pressure(bar)	25
	Maximum fluid viscosity (mm²/s)	25cSt
	Ambient temperature: with class F solenoid coil (°C)	-10 ... +55
	Ambient temperature: with class H solenoid coil (°C)	-10 ... +80
	Mounting position	Preferably with solenoid coil upwards

F3168 - 2-way solenoid valve N.C. brass body and cover, with G connection (ISO 228) - 3/8" ... 1 1/2

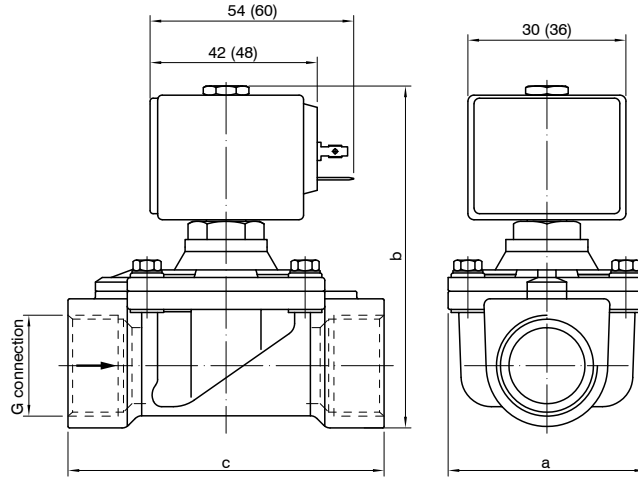

The data in brackets refer to the MK Series coil

CODE "V" = FPM seals	G connection (ISO 228) ⊕ = Connection						Orifice (mm)	KV (m ³ /h)	Differential pressure (bar)		Power consumption (W)	⊕ = Solenoid coil		Temperature range (°C)
	C	D	E	F	G	H			Min	Max		Series	Size	
	AC		DC											
F3168CV11B	3/8"			/			11	1,2	14	5	10	MG	30	-10 ... +140
									/	14	27	MK	36	
F3168CV16B	/	1/2"		/			16	2,4	14	2,5	10	MG	30	
									/	14	27	MK	36	
F3168CV16B	/		3/4"	/			16	2,4	14	2,5	10	MG	30	
									/	14	27	MK	36	
F3168CV20HB	/		3/4"	/			20	7,2	16	5	10	MG	30	
									/	16	27	MK	36	
F3168CV25B	/			1"	/		25	7,2	8	/	10	MG	30	
									14	1,5	14	MK	36	
									/	6	27	MK	36	
F3168CV25HB	/			1"	/		25	8,4	16	5	10	MG	30	
									/	16	27	MK	36	
F3168CV35B	/			1" 1/4	/		35	16,2	16	/	10	MG	30	
									/	6	14	MK	36	
									/	16	27	MK	36	
F3168CV40B	/			1" 1/2	/		40	16,8	16	/	10	MG	30	
									/	6	14	MK	36	
									/	16	27	MK	36	

G connection	3/8"	1/2"	3/4"	3/4" (H)	1"	1" (H)	1" 1/4	1" 1/2
a	50	50	50	65	65	65	94	94
b	89	100	100	103	112	110	130	130
c	56	70	70	104	104	104	128	128

N.B. For use with steam maximum admitted pressure PS is 2,5 bar (relative pressure).

Example: F3168CV11B => F3168CV11MG5:

2-way solenoid valve normally closed, with assisted-lift diaphragm with G connection (ISO 228) 3/8", FPM seals, 11 mm orifice, solenoid coil 24 VDC (MG5, size 30 for more information, please refer to the section "Solenoid coils - Series F300").

Pneumatic symbol

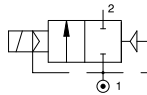

Diagram

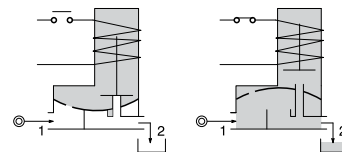

Construction characteristics	Technical characteristics	
<ul style="list-style-type: none"> - Brass body and cover - AISI 303 stainless steel guide tube - AISI 430FR stainless steel mobile and fixed core - AISI 302 stainless steel springs - FPM sealing assemblies (NBR on request) OPTIONS (on request): <ul style="list-style-type: none"> - NPT connections - ATEX Ex d explosion protection solenoid coil - For use with oxygen - certified solenoid coils 	Maximum admitted pressure (bar)	16
	Maximum fluid viscosity (mm ² /s)	25cSt
	Ambient temperature: with class F solenoid coil (°C)	-10 ... +55
	Ambient temperature: with class H solenoid coil (°C)	-10 ... +80
Mounting position	Preferably with solenoid coil upwards	



F3178 - 2-way solenoid valve N.C. stainless steel body and cover, with G connection (ISO 228) - 3/8" ... 1" 1/2

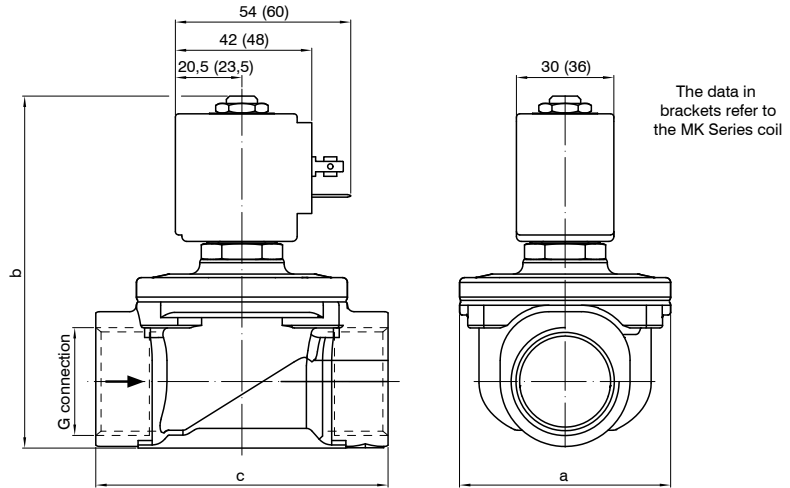

CODE "V" = FPM seals	G connection (ISO 228) ⊕ = Connection						Orifice (mm)	KV (m ³ /h)	Differential pressure (bar)		Power consumption (W)	⊕ = Solenoid coil		Temperature range (°C)
	C	D	E	F	G	H			Min	Max		Series	Size	
										AC	DC			
F3178⊕V15⊕	3/8"			/			15	2,4	14	6	10	MG	30	-10 ... +140
									/	14	27	MK	36	
F3178⊕V16⊕	/	1/2"		/			16	3	14	6	10	MG	30	
									/	14	27	MK	36	
F3178⊕V20⊕	/		3/4"	/			20	3,6	14	6	10	MG	30	
									/	14	27	MK	36	
F3178⊕V25⊕		/		1"	/		25	8,4	14	3	10	MG	30	
									/	8	14	MK	36	
F3178⊕V35⊕		/		1" 1/4	/		35	18	8	/	10	MG	30	
									14	2	14	MK	36	
F3178⊕V40⊕		/		1" 1/2			40	19,2	/	7	27	MK	36	
									8	/	10	MG	30	
									14	2	14	MK	36	
									/	7	27	MK	36	

G connection	3/8"	1/2"	3/4"	1"	1" 1/4	1" 1/2
a	52	52	58	65	94	94
b	92	92	100	109	126	126
c	68	68	75	90	128	128

N.B. For use with steam maximum admitted pressure PS is 2,5 bar (relative pressure).

Example: F3178⊕V15⊕ => F3178CV15MG5:

2-way solenoid valve normally closed, with assisted-lift diaphragm with G connection (ISO 228) 3/8", FPM seals, 15 mm orifice, solenoid coil 24 VDC (MG5, size 30 for more information, please refer to the section "Solenoid coils - Series F300").

Pneumatic symbol

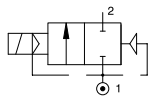

Diagram

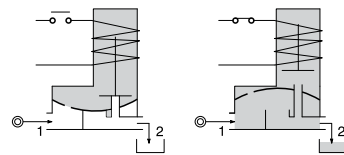

Construction characteristics	Technical characteristics	
<ul style="list-style-type: none"> - AISI 316 stainless steel body and cover - AISI 316 stainless steel guide tube - AISI 430FR stainless steel mobile and fixed core - AISI 302 stainless steel springs - Silver advance ring - FPM sealing assemblies (NBR on request) OPTIONS (on request): <ul style="list-style-type: none"> - NPT connections - ATEX Ex d explosion protection solenoid coil - For use with oxygen - certified solenoid coils 	Maximum admitted pressure (bar)	16
	Maximum fluid viscosity (mm ² /s)	25cSt
	Ambient temperature: with class F solenoid coil (°C)	-10 ... +55
	Ambient temperature: with class H solenoid coil (°C)	-10 ... +80
Mounting position	Preferably with solenoid coil upwards	

**FX3168 - 2-way solenoid valve N.C. brass body, with G connection (ISO 228)
with certified housing: Ex d IIC T6 or T5 or T4 Gb - 3/8" ... 1"**

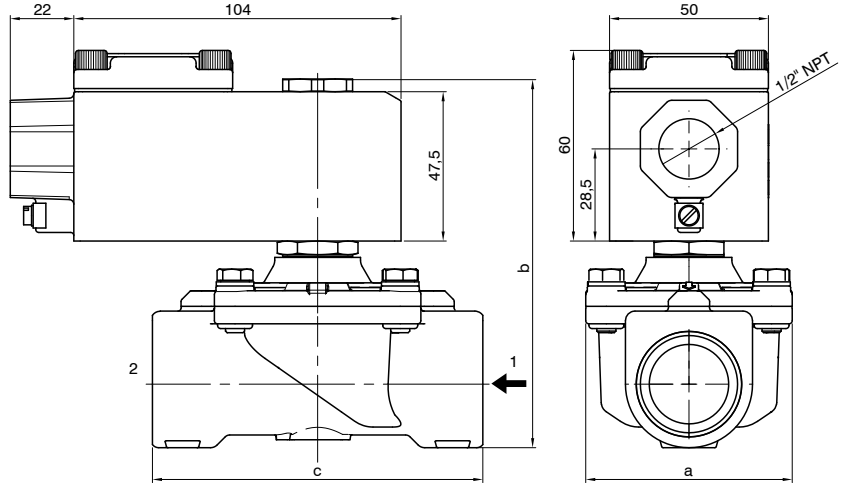

CODE "V" = FPM seals	G connection (ISO 228) ⊕ = Connection				Orifice (mm)	KV (m³/h)	Differential pressure (bar)			Power consumption (W)	⊕ = Solenoid coil	Temperature range (°C)
	C	D	E	F			Min	Max				
								AC	DC			
FX3168⊕V11⊕	3/8"		/		11	1,2	0	5	5	8	A6B= 24 Volt (AC 50-60 Hz) A6E= 220/230 Volt (AC 50-60 Hz) A60= 12 Volt (DC) A61= 24 Volt (DC)	-10 ... +80
FX3168⊕V16⊕	/	1/2"	/		16	2,4		5	5			
FX3168⊕V16⊕	/	/	3/4"	/	16	2,4		5	5			
FX3168⊕V20H⊕	/	/	3/4"	/	20	7,2		5	5			
FX3168⊕V25H⊕	/	/		1"	25	8,4		5	5			

G connection	3/8"	1/2"	3/4"	3/4" (H)	1" (H)
a	50	50	50	65	65
b	95	106	106	109	116
c	56	70	70	104	104

Example: FX3168⊕V11⊕ => FX3168CV11A60:

2-way solenoid valve normally closed, with assisted-lift diaphragm with certified housing: Ex d IIC T6 or T5 or T4 Gb, with G connection (ISO 228) 3/8", FPM seals, 11 mm orifice, solenoid coil 12 VDC (A60).

Pneumatic symbol

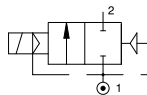

Diagram

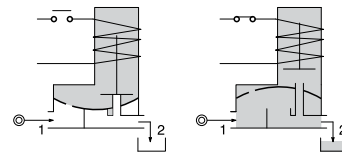

Construction characteristics

- Brass body
- Red light alloy housing
- 1/2" NPT electrical connection (M20x1,5 on request)
- FPM sealing assemblies

Technical characteristics

Maximum admitted pressure (bar)	16
Minimum differential pressure (bar)	0
Maximum fluid viscosity (mm²/s)	25cSt
Ambient temperature (°C)	-40 ... +60
Mounting position	Vertical with solenoid coil upwards



**FX3178 - 2-way solenoid valve N.C. stainless steel body, with G connection (ISO 228)
with certified housing: Ex d IIC T6 or T5 or T4 Gb - 3/8" ... 1"**

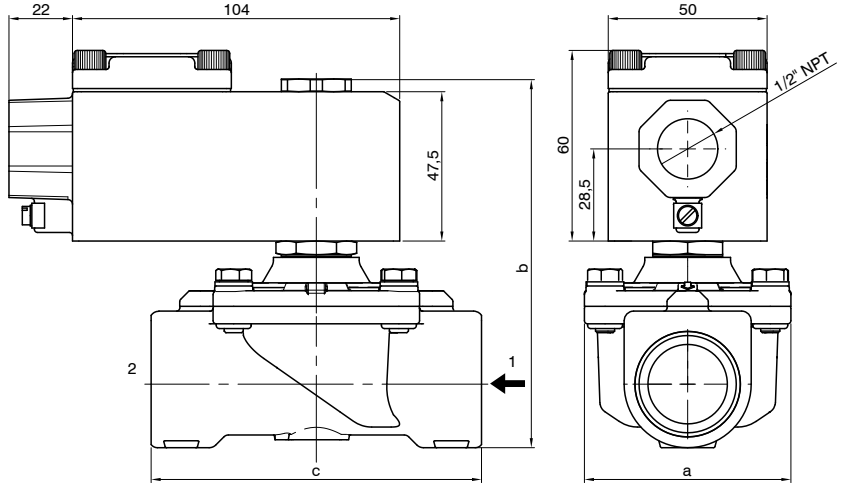

CODE "V" = FPM seals	G connection (ISO 228) ⊕ = Connection				Orifice (mm)	KV (m³/h)	Differential pressure (bar)			Power consumption (W)	⊖ = Solenoid coil	Temperature range (°C)
	C	D	E	F			Min	Max				
								AC	DC			
FX3178⊕V15⊖	3/8"	/	/	/	15	2,4	0	6	6	8	A6B= 24 Volt (AC 50-60 Hz) A6E= 220/230 Volt (AC 50-60 Hz) A60= 12 Volt (DC) A61= 24 Volt (DC)	-10 ... +80
FX3178⊕V16⊖	/	1/2"	/	/	16	3	6	6				
FX3178⊕V20⊖	/	/	3/4"	/	20	3,6	6	6				
FX3178⊕V25⊖	/	/	/	1"	25	8,4	3	3				

G connection	3/8"	1/2"	3/4"	1"
a	52	52	58	65
b	98	98	106	115
c	68	68	75	90

Example: FX3178⊕V15⊖ => FX3178CV15A60:

2-way solenoid valve normally closed, with assisted-lift diaphragm with certified housing: Ex d IIC T6 or T5 or T4 Gb, with G connection (ISO 228) 3/8", FPM seals, 15 mm orifice, solenoid coil 12 VDC (A60).

Pneumatic symbol

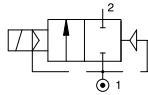

Diagram

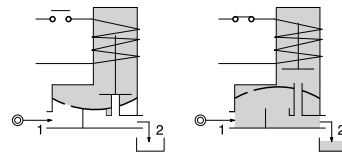

Construction characteristics	Technical characteristics	
- AISI 316 stainless steel body - Red light alloy housing - 1/2" NPT electrical connection (M20x1,5 on request) - FPM sealing assemblies	Maximum admitted pressure (bar)	16
OPTIONS (on request): - Solenoid coil with stainless steel housing	Minimum differential pressure (bar)	0
	Maximum fluid viscosity (mm²/s)	25cSt
	Ambient temperature (°C)	-40 ... +60
	Mounting position	Vertical with solenoid coil upwards

F3119 - 2-way solenoid valve N.C. brass body and cover, with G connection (ISO 228) - 1/4" ... 1/2"

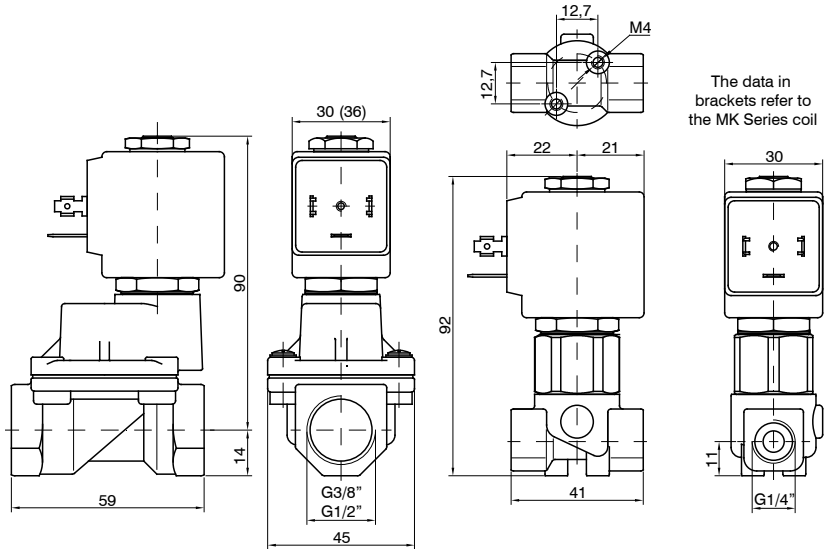

The data in brackets refer to the MK Series coil

CODE "V" = FPM seals	G connection (ISO 228) ⊕ = Connection			Orifice (mm)	KV (m ³ /h)	Differential pressure (bar)			Power consumption			⊕ = Solenoid coil		Temperature range (°C)
	B	C	D			Min	Max		AC Inrush (VA)	AC Holding (VA)	DC (W)	Series	Size	
							AC	DC						
F3119⊕V52⊕	1/4"	/	/	5,2	0,47	1,5	50	50	20	15	10	MG	30	-10 ... +140
F3119⊕V12⊕	/	3/8"	/	12	2	1	30	30						
F3119⊕V12⊕	/	/	1/2"	12	2,2	1	30	30	40	30	27	MK	36	
F3119⊕V12/1⊕	/	3/8"	/	12	2	1	50	50						
F3119⊕V12/1⊕	/	/	1/2"	12	2,2	1	50	50						

N.B. For use with steam maximum admitted pressure PS is 2,5 bar (relative pressure).

Example: F3119⊕V52⊕ => F3119BV52MG5:

2-way solenoid valve normally closed, servo-assisted piston with G connection (ISO 228) 1/4", main seals in PTFE other in FPM, 5,2 mm orifice, solenoid coil 24 VDC (MG5, size 30 for more information, please refer to the section "Solenoid coils - Series F300").

Pneumatic symbol

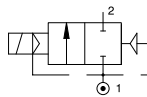

Diagram

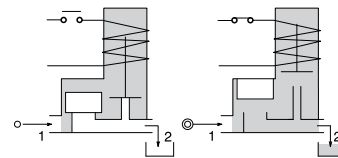

Construction characteristics	Technical characteristics	
- Brass body and cover	Maximum admitted pressure (bar)	60
- AISI 303 stainless steel guide tube	Maximum fluid viscosity (mm ² /s)	25cSt
- AISI 430FR stainless steel mobile and fixed core	Minimum differential pressure (bar)	1
- AISI 302 stainless steel springs	Maximum admitted leakage (Nl/h)	<0,2
- Brass piston	Ambient temperature: with class F solenoid coil (°C)	-10 ... +55
- PTFE piston seal	Ambient temperature: with class H solenoid coil (°C)	-10 ... +80
- Sealing assemblies mainly PTFE, others FPM	Mounting position	Preferably with solenoid coil upwards
OPTIONS (on request):	Weight (g) with solenoid coil MG series	630
- Chemical nickel plating	Weight (g) with solenoid coil MK series	710
- certified solenoid coils		



F3119W - 2-way solenoid valve N.C. brass body and cover, with G connection (ISO 228) - 3/8" and 1/2"

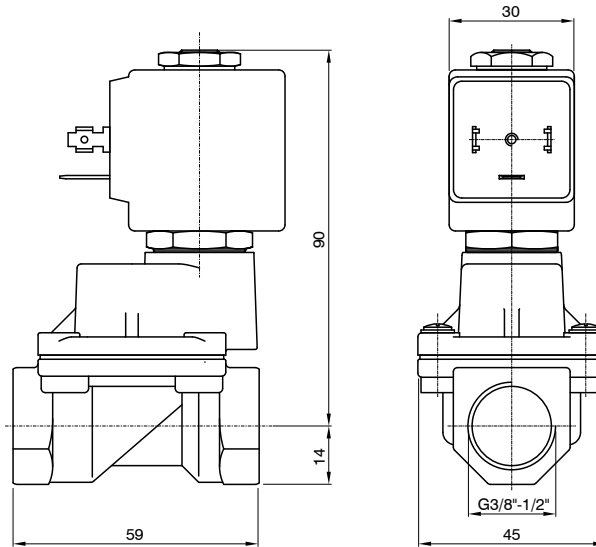

CODE "W" = PTFE seals	G connection (ISO 228) ⊕ = Connection		Orifice (mm)	KV (m ² /h)	Differential pressure (bar)		Power consumption			⊕ = Solenoid coil		Temperature range (°C)	
	C	D			Min	Max		AC Inrush (VA)	AC Holding (VA)	DC (W)	Series		Size
						AC	DC						
F3119⊕W12/1⊕	3/8"	/	12	2	2,5	10	10	20	15	10	MG	30	-10 ... +180
F3119⊕W12/1⊕	/	1/2"	12	2,2	2,5	10	10						

Example: F3119⊕W12/1⊕ => F3119CW12/1MG5:

2-way solenoid valve normally closed, servo-assisted piston for use with steam with G connection (ISO 228) 3/8", PTFE seals, 12 mm orifice, solenoid coil 24 VDC (MG5, size 30 for more information, please refer to the section "Solenoid coils - Series F300").

Pneumatic symbol

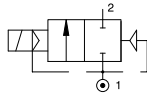

Diagram

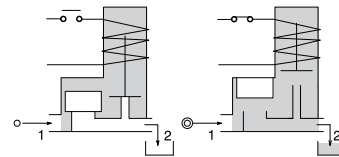

Construction characteristics	Technical characteristics	
<ul style="list-style-type: none"> - Brass body and cover - AISI 303 stainless steel guide tube - AISI 430FR stainless steel mobile and fixed core - AISI 302 stainless steel springs - AISI 303 stainless steel piston - PTFE piston seal - PTFE sealing assemblies OPTIONS (on request): <ul style="list-style-type: none"> - Chemical nickel plating surface treatment - certified solenoid coils 	Minimum differential pressure (bar)	2,5
	Maximum admitted leakage (Nl/h)	<0,2
	Ambient temperature: with class F solenoid coil (°C)	-10 ... +55
	Mounting position	Preferably with solenoid coil upwards
	Weight (g)	630

F3123 - 2-way solenoid valve N.C. brass body and cover, with G connection (ISO 228) - 3/8"

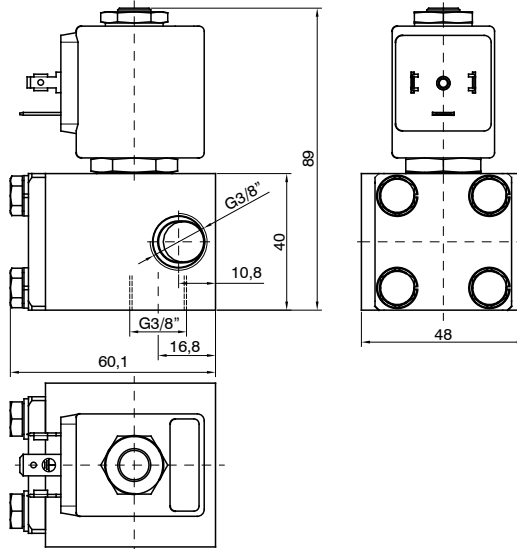

CODE "W" = PTFE seals	G connection (ISO 228) ⊕ = Connection	Orifice (mm)	KV (m ³ /h)	Differential pressure (bar)			Power consumption			⊕ = Solenoid coil		Temperature range (°C)
				Min	Max		AC Inrush (VA)	AC Holding (VA)	DC (W)	Series	Size	
					AC	DC						
F3123⊕W07⊕	3/8"	7	14	0,7	100	80	20	15	10	MG	30	-10 ... +95
					150	150	40	30	27	MK	36	

Example: F3123⊕W07⊕ => F3123CW07MG5:

2-way solenoid valve normally closed, servo-assisted piston with G connection (ISO 228) 3/8", main seals in PTFE other in FPM, 7 mm orifice, solenoid coil 24 VDC (MG5, size 30 for more information, please refer to the section "Solenoid coils - Series F300").

Pneumatic symbol

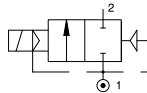

Diagram

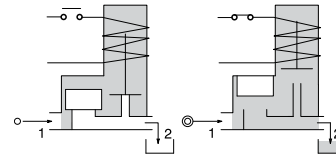

Construction characteristics	Technical characteristics	
- Brass body and cover	Maximum admitted pressure (bar)	200
- AISI 303 stainless steel guide tube	Maximum fluid viscosity (mm ² /s)	12cSt
- AISI 430FR stainless steel mobile and fixed core	Minimum differential pressure (bar)	0,7
- AISI 302 stainless steel springs	Maximum admitted leakage (NI/h)	<0,2
- AISI 303 stainless steel piston	Ambient temperature: with class F solenoid coil (°C)	-10 ... +55
- Sealing assemblies mainly PTFE, others FPM	Ambient temperature: with class H solenoid coil (°C)	-10 ... +80
OPTIONS (on request):	Mounting position	Preferably with solenoid coil upwards
- Chemical nickel plating		
- certified solenoid coils		



F3124 - 2-way solenoid valve N.C. brass body and cover, with G connection (ISO 228) - 1/2"

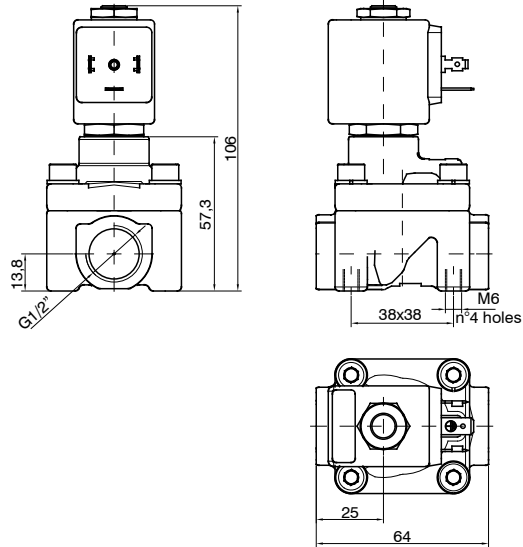

CODE "W" = PTFE seals	G connection (ISO 228) ⊙ = Connection	Orifice (mm)	KV (m ³ /h)	Differential pressure (bar)			Power consumption			⊙ = Solenoid coil		Temperature range (°C)
	D			Min	Max		AC Inrush (VA)	AC Holding (VA)	DC (W)	Series	Size	
					AC	DC						
F3124⊙W12⊙	1/2"	12	60	3	100	100	20	15	10	MG	30	-10 ... +95

Example: F3124⊙W12⊙ => F3124DW12MG5:

2-way solenoid valve normally closed, servo-assisted piston with G connection (ISO 228) 1/2", main seals in PTFE other in FPM, 12 mm orifice, solenoid coil 24 VDC (MG5, size 30 for more information, please refer to the section "Solenoid coils - Series F300").

Pneumatic symbol

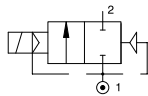

Diagram

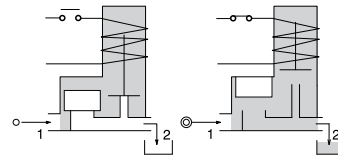

Construction characteristics	Technical characteristics	
<ul style="list-style-type: none"> - Brass body and cover - AISI 303 stainless steel guide tube - AISI 430FR stainless steel mobile and fixed core - AISI 302 stainless steel springs - PBT piston - Sealing assemblies mainly PTFE, others FPM OPTIONS (on request): <ul style="list-style-type: none"> - Chemical nickel plating - certified solenoid coils 	Maximum admitted pressure (bar)	150
	Maximum fluid viscosity (mm ² /s)	12cSt
	Minimum differential pressure (bar)	3
	Maximum admitted leakage (Nl/h)	<0,2
	Ambient temperature: with class F solenoid coil (°C)	-10 ... +55
	Mounting position	Preferably with solenoid coil upwards

F3224 - 2-way solenoid valve N.O. brass body and cover, with G connection (ISO 228) - 1/2"

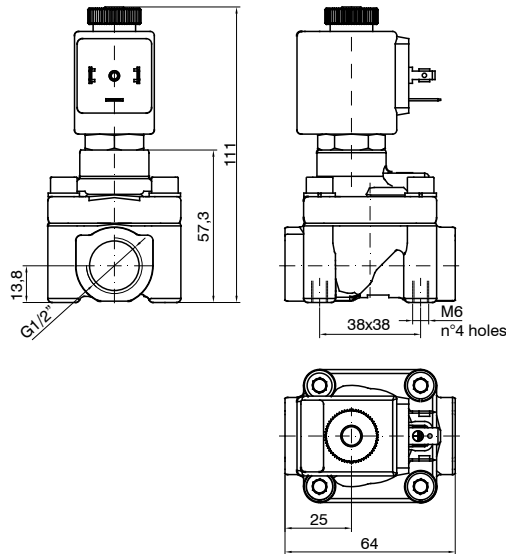

CODE "W" = PTFE seals	G connection (ISO 228) ⊕ = Connection	Orifice (mm)	KV (m ³ /h)	Differential pressure (bar)			Power consumption			⊕ = Solenoid coil		Temperature range (°C)
	D			Min	Max		AC Inrush (VA)	AC Holding (VA)	DC (W)	Series	Size	
					AC	DC						
F3224⊕W12⊕	1/2"	12	60	3	50	50	20	15	10	MG	30	-10 ... +95

Example: F3224⊕W12⊕ => F3224DW12MG5:

2-way solenoid valve normally open, servo-assisted piston with G connection (ISO 228) 1/2", main seals in PTFE other in FPM, 12 mm orifice, solenoid coil 24 VDC (MG5, size 30 for more information, please refer to the section "Solenoid coils - Series F300").

Pneumatic symbol

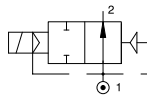

Diagram

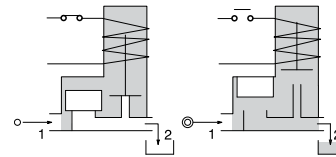

Construction characteristics	Technical characteristics	
<ul style="list-style-type: none"> - Brass body and cover - AISI 303 stainless steel guide tube - AISI 430FR stainless steel mobile and fixed core - AISI 302 stainless steel springs - PBT piston - Sealing assemblies mainly PTFE, others FPM OPTIONS (on request): <ul style="list-style-type: none"> - Chemical nickel plating - certified solenoid coils 	Maximum admitted pressure (bar)	100
	Maximum fluid viscosity (mm ² /s)	12cSt
	Minimum differential pressure (bar)	3
	Maximum admitted leakage (NI/h)	<0,2
	Ambient temperature: with class F solenoid coil (°C)	-10 ... +55
	Mounting position	Preferably with solenoid coil upwards

Solenoid coil 30 mm Ø13, type MG

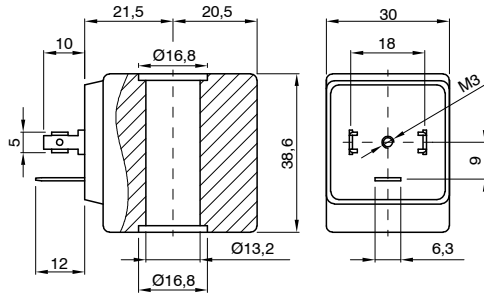

- Options:**
- Electrical connection via cables
 - Special voltages and powers
 - Self-extinguish

Ordering code	
MG	
VOLTAGE	
4=	12 VDC
5=	24 VDC
56=	24 VAC (50-60 Hz)
57=	110 VAC (50-60 Hz)
58=	230 VAC (50-60 Hz)
EAC	

Operational characteristics									
Class of insulation	Tolerance on AC voltage	Tolerance on DC voltage	IP Rating with connector	Continuous service	Electrical connection	Connector	Power		Weight (g)
							AC (VA)	DC (W)	
F	-10% ... +15%	±10%	IP65	ED100%	DIN 43650 A	Code: 300.11.00	15	10	120

Solenoid coil 22 mm Ø10, type MI

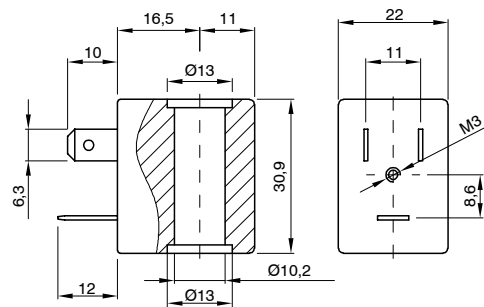

- Options:**
- Electrical connection via cables
 - Special voltages and powers
 - Self-extinguish

Ordering code	
MI	
VOLTAGE	
4=	12 VDC
5=	24 VDC
21=	48-50 VAC (50-60 Hz)
56=	24 VAC (50-60 Hz)
57=	110 VAC (50-60 Hz)
58=	230 VAC (50-60 Hz)
EAC	

Operational characteristics									
Class of insulation	Tolerance on AC voltage	Tolerance on DC voltage	IP Rating with connector	Continuous service	Electrical connection	Connector	Power		Weight (g)
							AC (VA)	DC (W)	
F	-10% ... +15%	±10%	IP65	ED100%	DIN 43650 B	Code: 305.11.00	8	6,5	50

Solenoid coil 36 mm Ø13, type MK

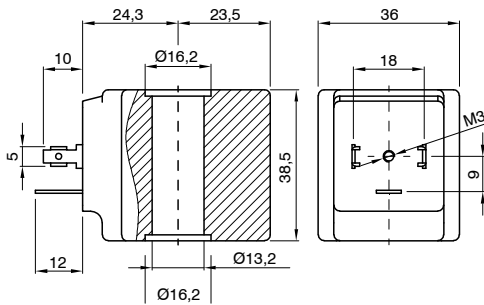

- Options:**
- Electrical connection via cables
 - Special voltages and powers
 - Self-extinguish

Ordering code	
MK	
VOLTAGE	
4=	12 VDC
5=	24 VDC
56=	24 VAC (50-60 Hz)
57=	110 VAC (50-60 Hz)
58=	230 VAC (50-60 Hz)
EAC	

Operational characteristics									
Class of insulation	Tolerance on AC voltage	Tolerance on DC voltage	IP Rating with connector	Continuous service	Electrical connection	Connector	Power		Weight (g)
							AC (VA)	DC (W)	
H	-10% ... +15%	±10%	IP65	ED100%	DIN 43650 A	Code: 300.11.00	30	27	200

Solenoid coil 30 mm Ø10, type XME

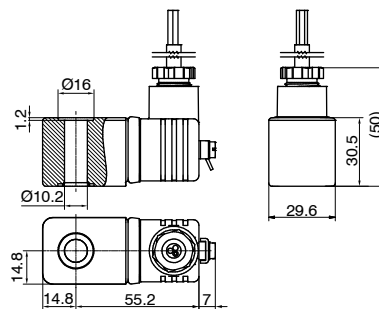

- CE II 2G Ex mb IIC T6, T5, T4 Gb
CE II 2D Ex mb IIC T85°C, T100°C, T135°C Db IP65

Ordering code	
XME-3	
VOLTAGE	
5=	24 VDC
56=	24 VAC (50-60 Hz)
57=	110 VAC (50-60 Hz)
58=	230 VAC (50-60 Hz)
Ex IECEx	

Operational characteristics								
Class of insulation	Tolerance on AC voltage	Tolerance on DC voltage	IP Rating with connector	Continuous service	Electrical connection	Power		Weight (g)
						AC (VA)	DC (W)	
H	-10% ... +15%	±10%	IP65	ED100%	3 m cable	5,3	5,4	325

Series PVF

Angle seat valves with AISI 316 or 304 stainless steel body.

2-way N.C. angle seat valve. Threaded ports (Designed to prevent water hammer) - 1/2" ... 3"

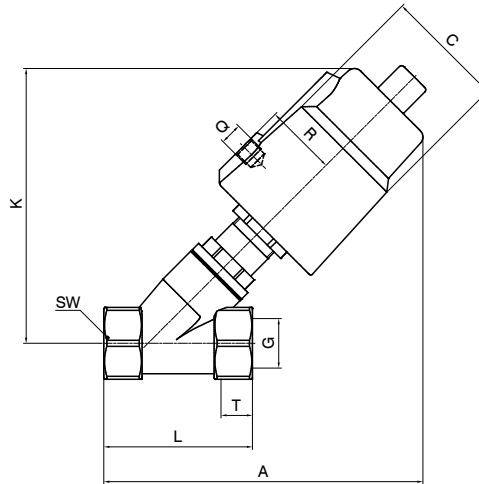

PNEUMAX FLUID CONTROL

Table of dimensions

CODE	☉ = Function		G connection	Actuator (mm)	C (mm)	R (mm)	K (mm)	Q (mm)	T (mm)	A (mm)	L (mm)	SW (mm)	☉ = Material	
	N.O.	N.C.											AISI	
PVF40☉15-M	0	1	1/2"	40	50,5	27	111	1/8"	15	119	68	27	304	316
PVF50☉15-M				50	60	33	124			131				
PVF50☉20-M			3/4"	50	60	33	132	1/8"	16	140	75	32		
PVF50☉25-M				50	60	33	136			145	90	40		
PVF63☉25-M			1"	63	75	41	162	1/8"	17	169				
PVF63☉32-M				63	75	41	174			1/8"	21	187		
PVF90☉32-M			1-1/4"	90	106	55	223	235						
PVF63☉40-M				1-1/2"	63	75	41	175	1/8"	21	187	116		
PVF90☉40-M			90		106	55	223	235						
PVF63☉50-M			2"	63	75	41	183	1/8"	22	201	138	69		
PVF90☉50-M				90	106	55	232			250				
PVF125A☉65-M			2-1/2"	125 (Aluminium)	148	74	302	1/4"	26	320	178	85		
PVF125A☉80-M			3"	125 (Aluminium)	148	74	313	1/4"	27	372	210	100		

Technical data (N.O. - N.C. versions)

CODE	☉ = Function		G connection	KV (m³/h)	Actuator (mm)	Maximum ΔP (bar) (N.O.)		Maximum ΔP (bar) (N.C.)		Pilot pressure (bar)	☉ = Material		
	N.O.	N.C.				Above seat	Under seat	Above seat	Under seat		AISI		
PVF40☉15-M	0	1	1/2"	4,8	40	16	16	16	13	3 ... 8	304	316	
PVF50☉15-M				4,8	50	16	16	16	14				
PVF50☉20-M			3/4"	10	50	12	16	16	14				
PVF50☉25-M				14	50	3	13	16	8				
PVF63☉25-M			1"	14	63	16	16	16	13				
PVF63☉32-M				23	63	14	13	16	6				
PVF90☉32-M			1-1/4"	23	90	/	/	16	16				
PVF63☉40-M				1-1/2"	30	63	14	7	16				5
PVF90☉40-M			30		90	/	16	16	16				
PVF63☉50-M			2"	70	63	6	5	9	3				
PVF90☉50-M				70	90	/	12	16	10				
PVF125A☉65-M			2-1/2"	107	125 (Aluminium)	/	14	16	9				
PVF125A☉80-M			3"	157	125 (Aluminium)	/	12	12	5				3 ... 10

Pneumatic symbol

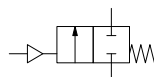

Construction characteristics	Technical characteristics (Valve body)	Technical characteristics (Actuator)
<ul style="list-style-type: none"> - High flow rate thanks to body configuration with inclined seating - Anti water hammer functioning with input below poppet - Pneumatically operated valve with stainless steel body, resistant to ambient corrosion - Self-levelling poppet to ensure improved sealing - Optical position indicator - Self-adjusting maintenance free stuffer seals package - Valves may be mounted in all positions <p>OPTIONS (on request):</p> <ul style="list-style-type: none"> - Double acting versions are available on request - Connection type: GAS ISO / NPT 	<ul style="list-style-type: none"> - Material: AISI 316/304 stainless steel - Fluid temperature: -10 °C ... + 180 °C - Ambient temperature: -10 °C ... + 80 °C - Fluid viscosity: max. 600cSt. - Poppet: PTFE - Seals package: PTFE and FKM 	<ul style="list-style-type: none"> - Body: AISI 304 - Pilot fluid: dry or lubricated air, gas and neutral fluids - Fluid temperature: max. +60 °C



2-way N.C. angle seat valve. Welded connection (Designed to prevent water hammer)

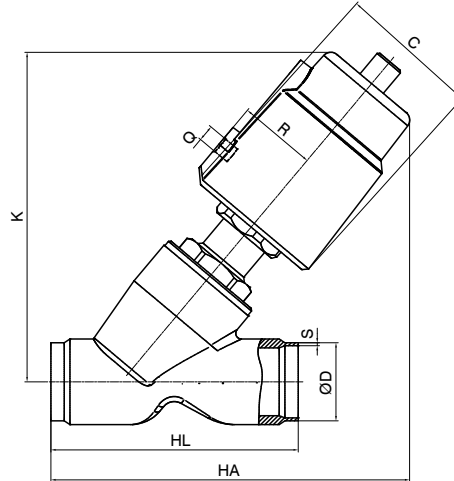

Table of dimensions

CODE	F= Function		Actuator (mm)	C (mm)	R (mm)	K (mm)	Q (mm)	HA (mm)	HL (mm)	DIN11850-2		DIN11850-3		M= Material	
	N.O.	N.C.								D	S	D	S	AISI 304	AISI 316
PVF40-15H-M	0	1	40	50,5	27	112	1/8"	118	70	19	1,5	20	2	A	B
PVF50-15H-M			50	60	33	125		128	20						
PVF50-20H-M			50	60	33	132		135	23	24					
PVF50-25H-M			50	60	33	136		150	29	30					
PVF63-25H-M			63	75	41	162		175	35	36					
PVF63-32H-M			63	75	41	174		186							
PVF90-32H-M			90	106	55	223		232	41	42					
PVF63-40H-M			63	75	41	175		190							
PVF90-40H-M			90	106	55	223		235	53	54					
PVF63-50H-M			63	75	41	183		206							
PVF90-50H-M			90	106	55	232		250							

Technical data (N.O. - N.C. versions)

CODE	F= Function		KV (m³/h)	Actuator (mm)	Maximum ΔP (bar) (N.O.)		Maximum ΔP (bar) (N.C.)		Pilot pressure (bar)	M= Material	
	N.O.	N.C.			Above seat	Under seat	Above seat	Under seat		AISI 304	AISI 316
PVF40-15H-M	0	1	4,8	40	16	16	16	13	3 ... 8	A	B
PVF50-15H-M			4,8	50	16	16	16	14			
PVF50-20H-M			10	50	12	16	16	14			
PVF50-25H-M			14	50	3	13	16	8			
PVF63-25H-M			14	63	16	16	16	13			
PVF63-32H-M			23	63	14	13	16	6			
PVF90-32H-M			23	90	/	/	16	16			
PVF63-40H-M			30	63	14	7	16	5			
PVF90-40H-M			30	90	/	16	16	16			
PVF63-50H-M			70	63	6	5	9	3			
PVF90-50H-M			70	90	/	12	16	10			

Pneumatic symbol

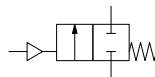

Construction characteristics	Technical characteristics (Valve body)	Technical characteristics (Actuator)
<ul style="list-style-type: none"> - High flow rate thanks to body configuration with inclined seating - Anti water hammer functioning with input below poppet - Pneumatically operated valve with stainless steel body, resistant to ambient corrosion - Self-levelling poppet to ensure improved sealing - Optical position indicator - Self-adjusting maintenance free stuffer seals package - Valves may be mounted in all positions <p>OPTIONS (on request):</p> <ul style="list-style-type: none"> - Double acting versions are available on request 	<ul style="list-style-type: none"> - Material: AISI 316/304 stainless steel - Fluid temperature: -10 °C ... +180 °C - Ambient temperature: -10 °C ... +80 °C - Fluid viscosity: max. 600cSt. - Poppet: PTFE - Seals package: PTFE and FKM 	<ul style="list-style-type: none"> - Body: AISI 304 - Pilot fluid: dry or lubricated air, gas and neutral fluids - Fluid temperature: max. +60 °C

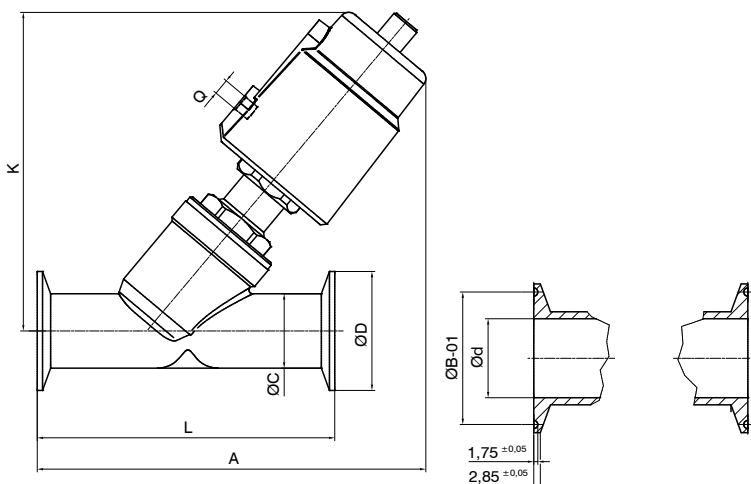
2-way N.C. angle seat valve. Clamp (Designed to prevent water hammer)

Table of dimensions

CODE	⊕ = Function		Actuator (mm)	A (mm)	K (mm)	Q (mm)	L (mm)	C (mm)	B (mm)	Ød	ØD	Ⓜ = Material	
	N.O.	N.C.										AISI 304	AISI 316
PVF40⊕15K-Ⓜ	0	1	40	130	115	1/8"	80	19	27,5	15	34	A	B
PVF50⊕15K-Ⓜ			50	140	126								
PVF50⊕20K-Ⓜ			50	158	148								
PVF50⊕25K-Ⓜ			50	165	140		130	32	43,5	27	50,5		
PVF63⊕25K-Ⓜ			63	188	166								
PVF63⊕32K-Ⓜ			63	200	174		146	37	43,5	31	50,5		
PVF90⊕32K-Ⓜ			90	245	223								
PVF63⊕40K-Ⓜ			63	210	175								
PVF90⊕40K-Ⓜ			90	255	223		160	40	56,5	33	64		
PVF63⊕50K-Ⓜ			63	221	185								
PVF90⊕50K-Ⓜ			90	265	235		175	53	56,5	45	64		

Technical data (N.O. - N.C. versions)

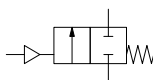
CODE	⊕ = Function		KV (m³/h)	Actuator (mm)	Maximum ΔP (bar) (N.O.)		Maximum ΔP (bar) (N.C.)		Pilot pressure (bar)	Ⓜ = Material	
	N.O.	N.C.			Above seat	Under seat	Above seat	Under seat		AISI 304	AISI 316
PVF40⊕15K-Ⓜ	0	1	4,8	40	16	16	16	13	3 ... 8	A	B
PVF50⊕15K-Ⓜ			4,8	50	16	16	16	14			
PVF50⊕20K-Ⓜ			10	50	12	16	16	14			
PVF50⊕25K-Ⓜ			14	50	3	13	16	8			
PVF63⊕25K-Ⓜ			14	63	16	16	16	13			
PVF63⊕32K-Ⓜ			23	63	14	13	16	6			
PVF90⊕32K-Ⓜ			23	90	/	/	16	16			
PVF63⊕40K-Ⓜ			30	63	14	7	16	5			
PVF90⊕40K-Ⓜ			30	90	/	16	16	16			
PVF63⊕50K-Ⓜ			70	63	6	5	9	3			
PVF90⊕50K-Ⓜ			70	90	/	12	16	10			

Pneumatic symbol

Construction characteristics	Technical characteristics (Valve body)	Technical characteristics (Actuator)
<ul style="list-style-type: none"> - High flow rate thanks to body configuration with inclined seating - Anti water hammer functioning with input below poppet - Pneumatically operated valve with stainless steel body, resistant to ambient corrosion - Self-levelling poppet to ensure improved sealing - Optical position indicator - Self-adjusting maintenance free stuffer seals package - Valves may be mounted in all positions <p>OPTIONS (on request):</p> <ul style="list-style-type: none"> - Double acting versions are available on request 	<ul style="list-style-type: none"> - Material: AISI 316/304 stainless steel - Fluid temperature: -10 °C ... +180 °C - Ambient temperature: -10 °C ... +80 °C - Fluid viscosity: max. 600cSt. - Poppet: PTFE - Seals package: PTFE and FKM 	<ul style="list-style-type: none"> - Body: AISI 304 - Pilot fluid: dry or lubricated air, gas and neutral fluids - Fluid temperature: max. +60 °C



▶ 2-way N.C. angle seat valve. Flange mounting (Designed to prevent water hammer)

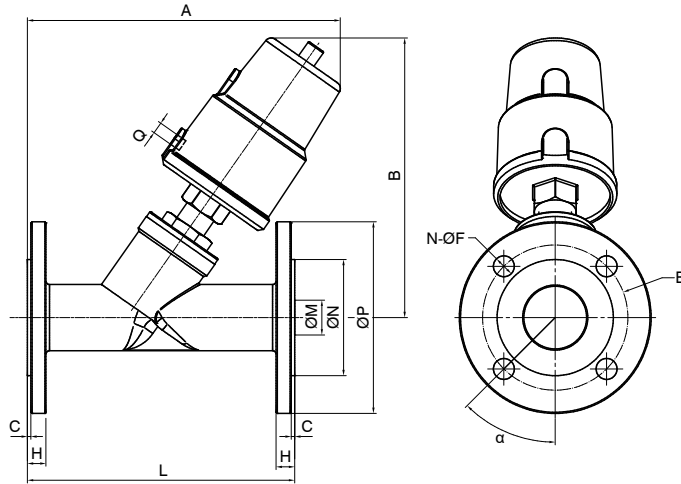

Table of dimensions

CODE	☉ = Function		Actuator (mm)	A (mm)	B (mm)	Q (mm)	L (mm)	C (mm)	H (mm)	ØE	N-ØF	ØM	ØN	ØP	α	☉ = Material		
	N.O.	N.C.														AISI 304	AISI 316	
PVF40☉15F-M	0	1	40	135	125	1/8"	130	2	14	65	4-14	16	45	95	45°	A	B	
PVF50☉15F-M			50	145	140		150	2	14	75	4-14	19	56	105				
PVF50☉20F-M			50	165	140		160	2	14	85	4-14	26	65	115				
PVF50☉25F-M			50	170	145		180	2	16	100	4-18	31	78	140				
PVF63☉25F-M			63	190	175		200	3	16	110	4-18	38	84	150				
PVF63☉32F-M			63	190	188		230	3	16	125	4-18	49	100	165				
PVF90☉32F-M			90	230	235		63	206	190									
PVF63☉40F-M			63	206	190		90	250	240									
PVF90☉40F-M			90	250	240		63	235	195									
PVF63☉50F-M			63	235	195		90	277	245									
PVF90☉50F-M			90	277	245													

Technical data (N.O. - N.C. versions)

CODE	☉ = Function		KV (m³/h)	Actuator (mm)	Maximum ΔP (bar) (N.O.)		Maximum ΔP (bar) (N.C.)		Pilot pressure (bar)	☉ = Material	
	N.O.	N.C.			Above seat	Under seat	Above seat	Under seat		AISI 304	AISI 316
PVF40☉15F-M	0	1	4,8	40	16	16	16	13	3 ... 8	A	B
PVF50☉15F-M			4,8	50	16	16	16	14			
PVF50☉20F-M			10	50	12	16	16	14			
PVF50☉25F-M			14	50	3	13	16	8			
PVF63☉25F-M			14	63	16	16	16	13			
PVF63☉32F-M			23	63	14	13	16	6			
PVF90☉32F-M			23	90	/	/	16	16			
PVF63☉40F-M			30	63	14	7	16	5			
PVF90☉40F-M			30	90	/	16	16	16			
PVF63☉50F-M			70	63	6	5	9	3			
PVF90☉50F-M			70	90	/	12	16	10			

Pneumatic symbol

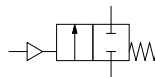

Construction characteristics	Technical characteristics (Valve body)	Technical characteristics (Actuator)
<ul style="list-style-type: none"> - High flow rate thanks to body configuration with inclined seating - Anti water hammer functioning with input below poppet - Pneumatically operated valve with stainless steel body, resistant to ambient corrosion - Self-levelling poppet to ensure improved sealing - Optical position indicator - Self-adjusting maintenance free stuffer seals package - Valves may be mounted in all positions <p>OPTIONS (on request):</p> <ul style="list-style-type: none"> - Double acting versions are available on request 	<ul style="list-style-type: none"> - Material: AISI 316/304 stainless steel - Fluid temperature: -10 °C ... +180 °C - Ambient temperature: -10 °C ... +80 °C - Fluid viscosity: max. 600cSt. - Poppet: PTFE - Seals package: PTFE and FKM 	<ul style="list-style-type: none"> - Body: AISI 304 - Pilot fluid: dry or lubricated air, gas and neutral fluids - Fluid temperature: max. +60 °C

Proximity sensor

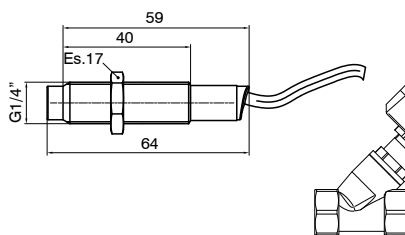

Ordering code	
PVF.0.S	
OUTPUT TYPE	
01 = NPN (N.C.)	
● 02 = NPN (N.O.)	
03 = PNP (N.C.)	
04 = PNP (N.O.)	

Nickel brass sensor, usable on valves up to size 2 inches for detection ON - OFF

Cable: 2 m

OPTIONS (on request):

A reduction is available for sizes 2 1/2" and 3".

Operational characteristics

Maximum current (mA)	Voltage field (VDC)	Temperature (°C)	Detection distance	IP Rating	Weight (g)
100	10 ... 30	-10 ... +70	3 mm (max) ±10%	IP67	69



Series PVA

Brass body angle seat valves and pad valve.

▶ **"T" body version pad valve**

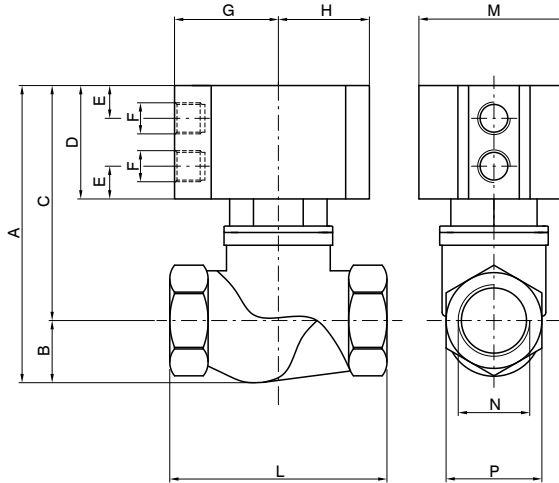

Ordering code	
PVA.B.A.P.T.C.M	
ACTING	
DE=	Double acting
SC=	Normally closed
SA=	Normally open
PISTON	
N=	Non magnetic
M=	Magnetic
CONNECTIONS	
A=	G1/4"
B=	G3/8"
C=	G1/2"
D=	G3/4"
E=	G1"
F=	G1 1/4"
G=	G1 1/2"
H=	G2"
SEALS	
N=	NBR
V=	FPM
F=	PTFE

Table of dimensions

Connection (N)	Non magnetic piston			Magnetic piston			B	E	F	G	H	L	M	P
	A	C	D	A	C	D								
G1/4"	93,5	77,5	41	97,5	81,5	45	16	10,25	G1/8"	32,5	28,5	64	47	25
G3/8"	93,5	77,5	41	97,5	81,5	45	16	10,25		32,5	28,5	64	47	25
G1/2"	93,5	78	41	99,5	82	45	17,5	10,25		32,5	28,5	68	47	30
G3/4"	105	83	41	113	90	48	22	11,25		44	40	79	70	36
G1"	117	89	41	125	101	53	28	11,25		44	40	94	70	44
G1 1/4"	131	103	48	136	108	53	28	11,25		44	40	110	70	55
G1 1/2"	154	118	57	166	130	69	36	13,75		56	49	120	90	60
G2"	169	124	57	181	136	69	45	13,75		56	49	140	90	73

Technical data

Actuator (O)	Valve (O)	Weight (g)
40	13,5	350
40	13,5	350
40	15	400
63	20,5	850
63	25	1100
63	30	1400
80	38	2100
80	49,5	3000

2-way valves, for interception of fluids, pneumatically actuated by a compact double or single acting cylinder with 360° swivel connections, NBR, FPM or PTFE seals in contact with the fluid. The barrel profile allows the use of magnetic sensors PNEUMAX code "1500_...", "RS_...", "RS_...", "HS_...", for sensor slot type "A" (see section 3, magnetic sensors series "SA" of the Pneumax General Catalogue).

Pressure curves

DOUBLE ACTING CYLINDER

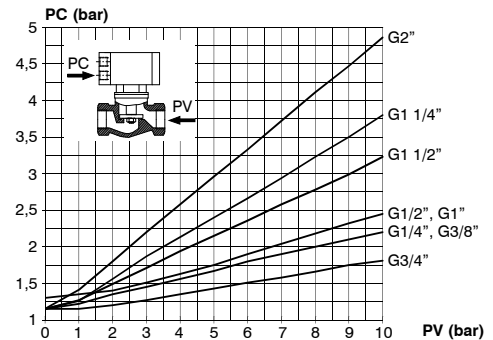
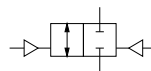
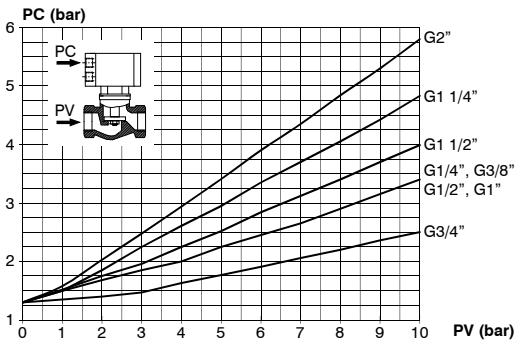

SINGLE ACTING CYLINDER, NORMALLY CLOSED VALVE

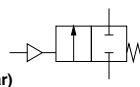
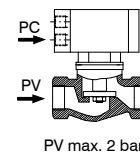
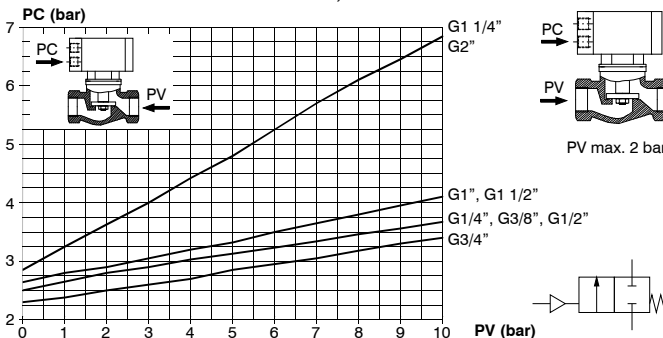

SINGLE ACTING CYLINDER, NORMALLY OPEN VALVE

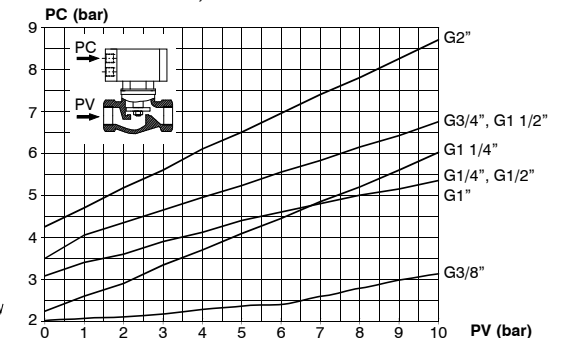

Construction characteristics	Technical characteristics	
- Rear eye, piston and rod bushing: anodised aluminium - Cylinder: aluminium alloy anodised - Springs: zinc plated steel - Seals in contact with fluid: NBR, FPM, PTFE - Pneumatic cylinder seals: NBR, FPM, PTFE - Piston rod: chromed stainless steel - Bushing, bushing pad, nut pad: brass	Pneumatic cylinder fluid	Filtered air. No lubrication needed, if applied it shall be continuous
	Valve fluid	Compatible fluid with seals compounds available
	Working pressure (Cylinder) (bar)	10
	Temperature °C (Non magnetic piston, NBR seals)	-10 ... +70
	Temperature °C (Non magnetic piston, FPM seals)	-10 ... +150
	Temperature °C (Non magnetic piston, PTFE seals)	-10 ... +150
	Temperature °C (Magnetic piston, NBR, FPM, PTFE seals)	-10 ... +70

“Y” body version pad valve

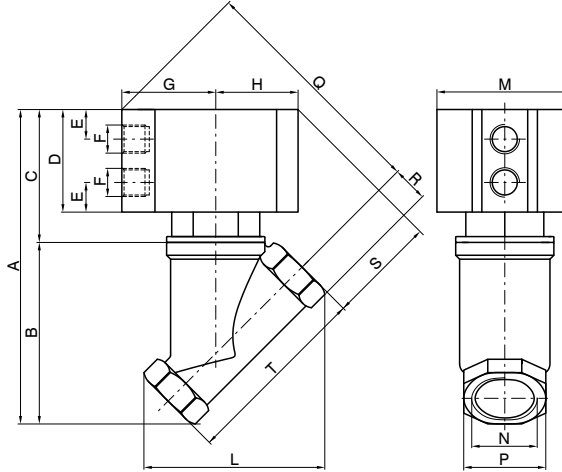

Ordering code	
PVA.B.A.ⓐ.Y.ⓐ.M	
ACTING	DE= Double acting
ⓐ	SC= Normally closed
	SA= Normally open
PISTON	
ⓑ	N= Non magnetic
	M= Magnetic
CONNECTIONS	
A=	G1/4"
B=	G3/8"
C=	G1/2"
ⓐ	D= G3/4"
	E= G1"
	F= G1 1/4"
	G= G1 1/2"
	H= G2"
SEALS	
ⓓ	N= NBR
	V= FPM
	F= PTFE

Table of dimensions

Connection (N)	Non magnetic piston					Magnetic piston					B	E	F	G	H	L	M	P	R	T
	A	C	D	Q	S	A	C	D	Q	S										
G1/4"	121	71	45	95	51	124	74	48	97	53	50	10,3	G1/8"	32,5	28,5	52	47	21	10,5	50
G3/8"	121	71	45	95	51	124	74	48	97	53	50	10,3		32,5	28,5	52	47	21	10,5	50
G1/2"	127	71	45	97	54	130	74	48	99	56	56	10,3		32,5	28,5	57	47	27	13,5	56
G3/4"	148	80	48	119	66	201	133	104	175	92	68	11,3		44	40	70	70	32	16	66
G1"	159	75	48	123	75	215	131	104	175	92	84	11,3		44	40	82	70	38	19	78
G1 1/4"	184	91	65	140	70	231	138	112	172	96	93	11,3		44	40	105	70	47	23,5	101
G1 1/2"	180	99	81	173	85	255	129	111	187	107	126	13,8		56	49	125	90	55	27,5	113
G2"	246	106	88	182	88	269	129	111	203	109	140	13,8		56	49	136	90	68	34	125

Technical data

Actuator (Ø)	Valve (Ø)	Weight (g)
40	13	350
40	13	350
40	13	400
63	18	850
63	21,5	850
63	30	1200
80	36	2000
80	46	2300

2-way valves, for interception of fluids, pneumatically actuated by a compact double or single acting cylinder with 360° swivel connections, NBR, FPM or PTFE seals in contact with the fluid. The barrel profile allows the use of magnetic sensors PNEUMAX code "1500_," "RS_," "RS_," "HS_," for sensor slot type "A" (see section 3, magnetic sensors series "SA" of the Pneumax General Catalogue).

Pressure curves

DOUBLE ACTING CYLINDER

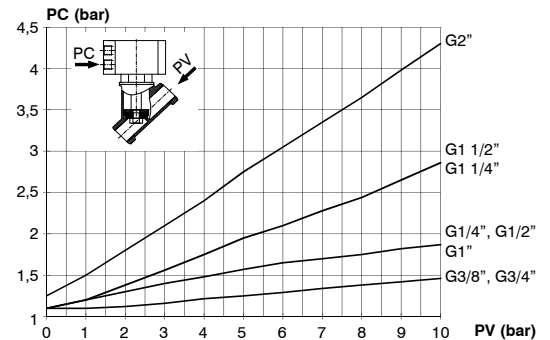
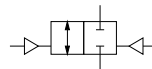
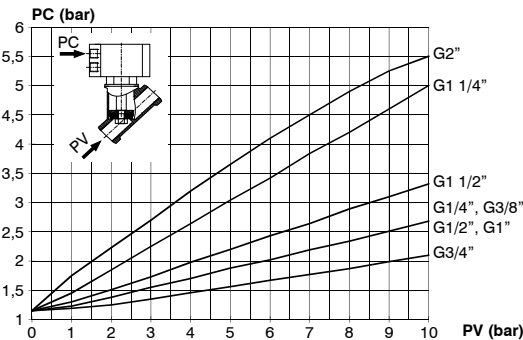

SINGLE ACTING CYLINDER, NORMALLY CLOSED VALVE

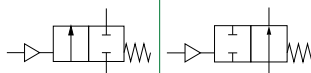
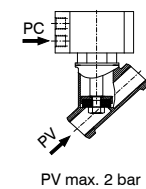
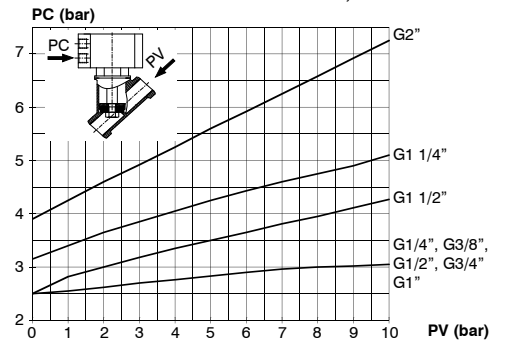

SINGLE ACTING CYLINDER, NORMALLY OPEN VALVE

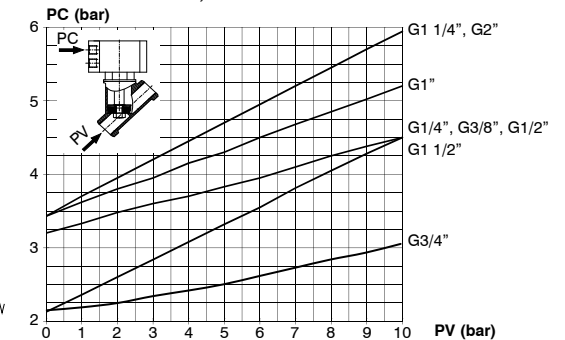

Construction characteristics	Technical characteristics	
<ul style="list-style-type: none"> - Rear eye, piston and rod bushing: anodised aluminium - Cylinder: aluminium alloy anodised - Springs: zinc plated steel - Seals in contact with fluid: NBR, FPM, PTFE - Pneumatic cylinder seals: NBR, FPM, PTFE - Piston rod: chromed stainless steel - Bushing, bushing pad, nut pad: brass 	Pneumatic cylinder fluid	Filtered air. No lubrication needed, if applied it shall be continuous
	Valve fluid	Compatible fluid with seals compounds available
	Working pressure (Cylinder) (bar)	10
	Temperature °C (Non magnetic piston, NBR seals)	-10 ... +70
	Temperature °C (Non magnetic piston, FPM seals)	-10 ... +150
	Temperature °C (Non magnetic piston, PTFE seals)	-10 ... +150
	Temperature °C (Magnetic piston, NBR, FPM, PTFE seals)	-10 ... +70



HEADQUARTERS



PNEUMAX

PNEUMAX S.P.A.

Via Cascina Barbellina, 10
24050 Lurano (BG) - Italia
Tel. 035/4192777
Fax 035/4192740 - 035/4192741
info@pneumaxspa.com
www.pneumaxspa.com

WORLDWIDE NETWORK

EUROPE

ALBANIA

Industrial Air Solution shpk
Rruga industriale Tirane Vore, km 11,
1032 Vore Tirane
Tel. +355 69 40 80 349
info@iasolution.al
www.iasolution.al

AUSTRIA AND SWITZERLAND

Managed by Pneumax GmbH (Germany)

BELGIUM

Pneuvano BV
Koralenhoeve 4
2160, Wommelgem
Tel. +32 3 355 32 20
info@pneuvano.com
www.pneuvano.com

BULGARIA

Ulmer DM OOD
Adam Mizkevich Str. 4a, 1360, Sofia
Tel. +359 (2) 9259951
office@ulmer.bg
www.ulmer.bg

CYPRUS

G C V Spare Parts & Services Ltd
Industrial Area, Anatoniko 8086
P.O. Box 62731, Paphos
Tel. +357 26812444
gcv.cy@cytanet.com.cy
www.gcv-parts.com

CROATIA

ProElektronika d.o.o. - Zagabria
Stefanovecka 10, 10040, Zagabria
Tel. +385 (0)1 5588 988
info@proelektronika.hr
www.proelektronika.hr

ESTONIA

Alas-Kuul AS
Loomäe tee 1, Lehmja küla
75306, Rae vald Harjumaa
Tel. +372 6593 218
info@alas-kuul.ee
www.alas-kuul.ee

FRANCE

Pneumax France SAS
Z.I. NORD PARADIES 7
Rue de Waldkirch - BP 42
67601, Selestat CEDEX
Tel. +33 (3) 88580450
commercial@pneumax-france.fr
www.pneumax-france.fr



GERMANY

Pneumax GmbH
Tantalstraße 4
63571, Gelnhausen
Tel. +49 (0) 6051 9777 0
info@pneumax-gmbh.de
www.pneumax.de



GREECE

Hydropneumatic Hellas S.A.
69, Spirou Patsi Str. T.K., 118 55, Atene
Tel. +30 (210) 3474181-2-3
info@mitsis.com.gr
www.mitsis.com.gr

UNITED KINGDOM

Pneumax UK Ltd.
110 Vista Park,
Mauretania Road
SO16 0YS, Nursling
Tel. +44 2380 740412
sales@pneumax.co.uk
www.pneumax.co.uk

ICELAND

Barki E.H.F. Ltd
Nybylavegi 22, 200, Kópavogur
Tel. +354 554 6499
barkiea@islandia.is

LITHUANIA

UAB "Domingos prekyba"
Savanoriu PR 187-4 Korp, 2053, Vilnius
Tel. +370 5 2322231
info@dominga.lt
www.dominga.lt

NORTHERN MACEDONIA

DIL KOM DOOEL
St. Joska Jordanoski No 657500, Prilep
Tel. +389 78244177
export.dilkom@gmail.com
www.dilkom.mk

MALTA

iAutomate Limited
San Bernard, Marsa MRS 1332, Malta
Tel. +356 2786 3996
matthew@iautomate.mt
www.iautomate.mt

NETHERLANDS

Pneu/Tec B.V.
Dirk Storklaan 75, 2132 PX, Hoofddorp
Tel. +31 (0) 235699090
sales@pneutec.nl
www.pneutec.nl

POLAND

Rectus Polska SP. Z.O.O.
Gumna 96, 43-426, Debowiec
Tel. +48 (33) 857 98 00
pneumax@pneumax.pl
www.pneumax.pl

PORTUGAL

Portugal Pneumax Lda
Complexo Industrial da
Granja Fracção H-Casarias
2625-607, Vialonga
Tel. +351 (219) 737390
geral@pneumax.pt
www.pneumax.pt



CZECH REPUBLIC

Pneumax Automation s.r.o.
U Panského mlýna 240/9,
747 06, Opava
Tel. +420 553 760 953
pneumax@pneumaxsro.cz
www.pneumaxsro.cz



ROMANIA

Gica Import Export
Zona Industriala de Vest str. II nr. 5,
310491, Arad
Tel. +40 257 259816
comercial@gica.ro
www.gica.ro



WORLDWIDE NETWORK

DENMARK - FINLAND NORWAY - SWEDEN (SCANDINAVIA)

Pneumax Scandinavia AB
Strandvägen 101, SE-234 31, Lomma
Tel. +46 (40) 617 40 40
info@pneumax.se
www.pneumax.se



SERBIA

Hidraulika DOO
Cirila i Metodija 15, 15000, Šabac
Tel. +381 15 360 090
info@hidraulika.rs
www.hidraulika.rs

SLOVENIA

Hidravlika d.o.o.
Medlog, 16, 3000, Celje
Tel. +386 (3) 5453610
info@hidravlika.si
www.hidravlika.si

TRG d.o.o.

Celovška cesta 150, 1000, Ljubljana
+386 1 500 14 51
info@podjetje-trg.si
www.podjetje-trg.si

SPAIN

Pneumax S.A.
Olaso Kalea, 54, 20870, Elgoibar
Tel. +34 943 744144
pneumax@pneumax.es
www.pneumax.es



Pneumax Catalunya S.A.

C/Riera de Vallvidrera,
Parc. 2N. 1 Pl. Riera del Moli
8750, Molins de Rei
Tel. +34 (93) 680 25 30
pneumax@pneumaxcat.com
www.pneumax.es



TURKEY

Eteknik Otomasyon Tic. Ltd. Sti
Perpa Ticaret Merkezi B Blok Kat:11 No:1636 Ok-
meydanı Sisli (Istanbul)
Tel. +90 212 320 81 10
recepakar@eteknik.com
www.eteknik.com

UKRAINE

UKRTECHTRONIC LLC.
st. Nyzhnoyurkivska, 9, 04080, Kiev
Tel. +38 044 500 98 48
sales@techtronic.com.ua
www.techtronic.com.ua

HUNGARY

Szele-Tech Bt.
Gvadányi u. 33-39. I. em. 108., 1141, Budapest
Tel. +36 1 401 0023
info@szele-tech.hu
www.szele-tech.hu

NORTH AMERICA

CANADA

Manufacture Scorpion Inc.
561, rue Edouard, J2G 3Z5, Granby
Tel. +1 (450) 378-3595
contact@mscopyon.com
www.manufacturescorpion.com

USA

Pneumax Automation LLC
128 Durkee Lane, Dallas
NC 28034 - USA
Tel.: +1 704 215 6991
Fax: +1 888 613 6529
info@pneumax.us
www.pneumax.us



MEXICO

Pneumatecna S.A. DE C.V. - Zapopan
Calle Volcán Popocatepetl 1844, Colli Urbano
45070, Zapopan, Jalisco
Tel. +52 33 31255978
pneumatecna@yahoo.com.mx
www.pneumatecna.com.mx

CENTRAL AMERICA

COSTA RICA

PYASA Proyectos y Automatización S.A.
Oficentro Santa María Oficina 1A,
50 metros Norte
Del Hampton Inn & Suites, Alajuela
Tel. +506 2441-5129 / 2441-5130
info@pyasa.net
<https://pyasa.net>

EL SALVADOR

Tecni Equipos S.A. de C.V.
Av. Sierra Nevada, 704 Edificio CC, 2
Colonia Miramonte, San Salvador
Tel. (503) 2260-8293
Tel. (503) 2261-1497
tecniequipos.com.sv

GUATEMALA

PYASA Proyectos y Automatización S.A.
Avenida 3era 13-30 El Rosario Ofibodegas
San Javier zona 3 de Mixco bodega 7
Ciudad del Guatemala
Tel. +502 24911414
info@pyasa.net
<https://pyasa.net>

NICARAGUA

PYASA Proyectos y Automatización S.A.
Plaza Maranhao, local 7, Reparto Los Robles, o
bien, del Hotel Seminole 100 m sur,
1/2 m al oeste
Managua
Tel. +505-2255-6840
info@pyasa.net
<https://pyasa.net>

SOUTH AMERICA

ARGENTINA

Figli Daniele S.r.l.
PTE PERON 3234
San Justo - Pcia De Bs As.
Tel. +54 11 4484-2074
Fax +54 11 4651-6721
bruno@dinautomacion.com.ar
www.dinautomacion.com.ar

BRAZIL

Pneumax Brasil
Rua Apucarana 211
8301050, São José dos Pinhais
Tel. +55 41 33987262
diretoria@pneumaxbr.com.br
www.pneumaxbr.com.br



CHILE

Schultz Automización e Ingeniería Ltda
El Retiro 1247 - Enea - Pudahuel, Santiago
Tel. +56 (2) 4951400
jschultz@schultzautomatizacion.cl
www.schultzsa.cl

COLOMBIA

Soluciones Neumaticas S.A.S.
Calle. 21 #1-21, Barrio San Nicolas, Cali
Tel. +57 (2) 4897647
ingenieria@solucionesneumaticas.com
www.solucionesneumaticas.com

ECUADOR

**Equipos para automatización
Industrial Equipautind S.A.**
Km 12,5 de la vía a Daule s/n entre
La Ciudadela el caracol y el motel las Palmas
090706, Guayaquil
Tel. +593-42017785 / 2017914
info@equipautind.com.ec
www.equipautind.com.ec

AINSA S.A.

Av. Juan Tanco Marengo
Km 2,5 y Agustín Freire
EC090509, Guayaquil
Tel. +593-4 3712670
info@ainsa.com.ec
www.ainsa.com.ec

PERU

Neumatec Perú S.A.C.
Calle General Suárez 1023,
Miraflores, Lima 18
Tel. +51 (1) 4442499
ventas@neumatecperu.com
www.neumatecperu.com

WEF Perú S.A.C.

Jr. Dinamarca 1427,
LIMA 01, Cercado de Lima
Tel. +51 1 4255740
oficinacentral@wefperu.com
www.wefperu.com

URUGUAY

Secoin S.A
General Aguilar 1270 bis,
Gral. Fausto Aguilar 1270,
11800 Departamento de Montevideo
Tel. +598 2209 3815
ventas@secoin.com.uy
www.secoin.com.uy

VENEZUELA

Sinteco Barquisimeto
AV.Las Industrias Km2,
Edif. Centro de servicios
mercantiles local 2, Barquisimeto
Tel. +58 414 3500587
sintecobarqto@gmail.com



AFRICA

ALGERIA

C.M.P.R. Sarl
23 Rue Lalla Fatma N'Soumeur Hassen
Badi El-Harrach, Algeri
Tel. +213 21 82 70 69
tn.cmpr@yahoo.fr

EGYPT

Egyptian Engineering
Shop 6 building no 1 Jordan co.
10th Of Ramadan City
Tel. +20554368385
Fax: +20554368385
info@eehydronpneu.com
www.eehydronpneu.com

ALKHAMIS Hydraulic Company

A/6 Elfarouqia Buildings -Gesr
El Suis St., El Nozha Cairo
Tel. +20 2 26206391/3/2
Fax: +20 2 26206394
gkhamisimp@gmail.com
www.alkhamis-eg.com

GHANA

Cemix Limited
34 SPINTEX ROAD-ACCRA-GHANA-WEST
Tel. +233 0302 817030
sales@cemixghana.com
www.cemixghana.com

MOROCCO

R2i TFZ
lIot 87, 1er étage, Bureau 20,
zone franche d'Exportation Tanger
Tel. +212 539 39 10 17
r2itfz@r2imaroc.ma
www.r2itfz.com

TUNISIA

L'Equipement moderne
86, Av. de Carthage, 1000, Tunis
Tel. +216 71 343844
equipement.moderne@planet.tn
www.equipementmoderne.com.tn

ASIA

SAUDI ARABIA

Arabian Universal Establishment for Trading
Southern Shopping Center, P.O BOX 3105
21471, Jeddah
Tel. +966 26 477159
bassam@aue-co.com
www.arabianuniversal.com

CHINA

Pneumax Pneumatic Equipments Co., Ltd.
No. 76, Jinma Rd., Jiufu Economic
Development Zone, Jiuting Town
201615, PRC, Shanghai
Tel. +86 (21) 57763100
sales@pneumaxchina.com
www.pneumaxchina.com



UNITED ARAB EMIRATES

Fine Industrial & Agri ENG. Services
P. O. BOX 5763, Sharja UAE
Tel. +971 (6) 5335434
fineinds@emirates.net.ae

PHILIPPINES

Integrated Hydro-Pneumatic Systems, Inc.
N°4 St. Thomas Avenue,
Lopez Commercial Area
Sucat, Parañaque City
Tel. +632 02 820-0569
integhps@iconex.net

JORDAN

Al Sultan Company
P.O. Box 620996
11162, Amman
Tel: + 962 6 4753764
info@alsultanco.com
www.alsultanco.com

INDIA

Pneumax Pneumatic India Pvt. Ltd.
D-82, Hosiery Complex, Phase-II extrn.
201305, Noida, UP
Tel. +91 (120) 4352560 / 61 / 62
info@pneumax-india.com
www.pneumaxindia.com



INDONESIA

Managed by Pneumax Singapore Pte Ltd

PT. Mutiara Citramulia Teknindo
Ruko Karawaci Residence Blok A1,
No. 17 Jl. Raya
Legok. Bojong Nangka Kelapa Dua
Serpong-Tangerang 15810, Banten, 15810,
Giacarta
Tel. +62 21 29324792
pneumaxmct@cbn.net.id
www.pneumaxspa.com/en

IRAN

Ital Electro Pneumatic
NO. 204-2ND FLOOR-TAGHINIA
BLDG-SOUTH SA'ADI STREET
114715719, Teheran
Tel. +98 (21) 33919177
info@italpneum.com

ISRAEL

Ilan & Gavish
Yokneam Ilit 20692
POB 335, Soltam Site
Tel. +972 3 9221824
mail@ilan-gavish.com
www.ilan-gavish.co.il

LEBANON

Yamine Trading Company SARL
Boushrieh, Industrial City, P.O. Box 90 684
Jdeideh, El Metn 1202
2060, Beirut
Tel. +961 1 885520
info@yamminetrading.com
www.yamminetrading.com

MALAYSIA

Managed by Pneumax Singapore Pte Ltd
PSI Pneumatic Control Sdn Bhd
4M (1) Desa Universiti Commercial Complex,
Jalan Sungai Dua
11700, Penang
Tel. +60 4 6592627
sales-psi@airdynamics.com.sg

OMAN

Muscat Pneumatic System & Project LLC
Shop # 1484, Building # 1450B,
P.O. Box 105 PC: 120,
Muscat, Sultanate Of Oman
Tel. +968 93989398
sales@muscat-pneumatic.com

PAKISTAN

Fluid Teknik
Suite 101-104 Industrial Town Plaza, Opp. Sind
Madressah, Shahrah-e-Liaquat
74000, Karachi
Tel. +92 (21) 2410335
info@fluid-technik.com.pk
www.fluid-technik.com.pk

SINGAPORE

Pneumax Singapore Pte Ltd
51, Ubi Avenue 1/ 01-16,
Paya Ubi Industrial Park
408933, Singapore
Tel. +65 6392 0581
sales@pneumax.com.sg
www.pneumax.com.sg



SYRIA

Al Rowad Trading
P.O. BOX. 12806
Damasco
Tel: +963 944 228 955
alrowadtrading01@hotmail.com

THAILAND

Thai Agency Engineering Co. LTD
9 Soi Yasoop 2, 2nd-3rd Floor, Vorasin
building, Vipavadirangsit Road, Ladyao
10900, Chumphon
Tel: +66 (2) 6915900
taec@bkk.loxinfo.co.th
www.thai-a.com

OCEANIA

AUSTRALIA

Air Automation Group Pty Ltd
15 Broadhurst Rd,
Ingleburn NSW 2565
Tel. +61 02 9618 6777
sales@airautomation.com.au
www.airautomation.com.au

NEW ZEALAND

Treotham Automation Pty Ltd
Level 4, 21 Putney Way,
Manukau Auckland 2104
Tel. +64 9278 6577
Fax: +64 9278 6578
info@treotham.co.nz
www.treotham.co.nz



PNEUMAX

PNEUMAX S.p.A.

Via Cascina Barbellina, 10

24050 Lurano (BG) - Italy

P. +39 035 41 92 777

info@pneumaxspa.com

www.pneumaxspa.com