



Instruction Manual

NDIR TYPE INFRARED GAS ANALYZAR

TYPE: ZPG

Horizontal type
ZPGA, ZPGD

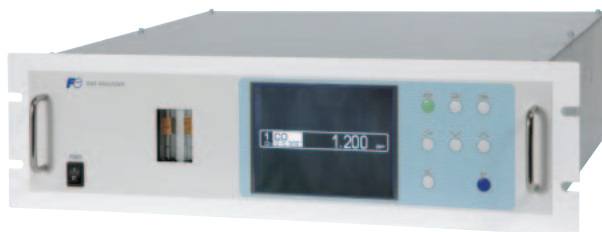

Vertical type
ZPG3E
(Replacement of ZRG3)
(Sample switching
system type)



PREFACE

Thank you very much for purchasing Fuji's Infrared Gas Analyzer (Type: ZPG).

- Be sure to read this instruction manual carefully before performing installation, wiring, operation, and maintenance of the analyzer. Improper handling may result in accidents or injury.
- The specifications of this analyzer are subject to change without prior notice for further product improvement.
- Modification of this analyzer is strictly prohibited unless a written approval is obtained from the manufacturer. Fuji will not bear any responsibility for a trouble caused by such a modification.
- The person who actually operates the analyzer should keep this instruction manual.
- After reading through the manual, be sure to keep it near at hand for future reference.
- This instruction manual should be delivered to the end user without exception.

Manufacturer : Fuji Electric Co., Ltd.
Type : Described in the nameplate on main frame
Date of manufacture : Described in the nameplate on main frame
Country of manufacture : Japan

Request

- No part or the whole of this manual may be reproduced without written permission of Fuji.
- Description in this manual is subject to change without prior notice for further improvement.



© Fuji Electric Co., Ltd. 2012



Issued in September, 2012
Rev. 1st edition May, 2014
Rev. 2nd edition October, 2015
Rev. 3rd edition September, 2016

CAUTION ON SAFETY

To operate the analyzer properly, be sure to read “Caution on Safety” carefully.



- The descriptions listed here provide important information on safety. Be sure to observe them at all times. Those safety precautions are classified into 3 levels, “DANGER,” “CAUTION” and “PROHIBITION.”

 DANGER	Improper handling may cause dangerous situations that may result in death or serious injury.
 CAUTION	Improper handling may cause dangerous situations that may result in medium-level troubles, minor injury, or property damage.
 PROHIBITION	Items which must not be done are indicated.



Caution on installation and transport of gas analyzer	
 DANGER	<ul style="list-style-type: none"> • The unit is not of explosion-proof specifications. Do not use it in an atmosphere of explosive gases. Otherwise, serious accidents such as explosion or fire may result.
 CAUTION	<ul style="list-style-type: none"> • For installation, observe the rule on it given in the instruction manual, and select a place where the weight of analyzer can be supported. Installation in an inadequate place may cause turnover or falling, resulting in injury. • Be sure to wear protective gloves when lifting the analyzer. Lifting it with bare hands may result in injury. • Be sure to fix the cover before transporting the analyzer. Transportation in unstable state may result in injury. • The gas analyzer is heavy. To transport the analyzer, please use a hand cart or equivalent. Prevent from carrying analyzer by hand as much as possible. Otherwise, unexpected harm to your body or injury may result. • Take care not to let cable chips and other foreign objects enter the unit during installation work. Otherwise, fire, failure, or malfunction may result.

Caution on piping	
 DANGER	<p>Be sure to observe the following precautions while installing piping. Improper piping may result in gas leakage.</p> <p>If the leaking gas contains a toxic component, serious accidents may result. If it contains combustible gases, explosion or fire may result.</p> <ul style="list-style-type: none"> • Connect pipes correctly referring to the instruction manual. • Discharge the exhaust gas outdoors to prevent it from remaining within the sampling device or indoors. • Relieve the exhaust gas from the analyzer to the atmospheric pressure to prevent buildup of undesirable pressure to the analyzer. Otherwise, piping within the analyzer may be disconnected, resulting in gas leakage. • Use pipes and pressure reducing valves to which no oil/grease is attached to the piping. Otherwise, fire may result.

Caution on wiring	
 CAUTION	<ul style="list-style-type: none"> • Be sure to turn off the power before installing wiring. Otherwise, electric shock may result. • Be sure to perform protective earth ground connection. Otherwise, electric shock or failure may result. • Select a proper wiring material that satisfies the ratings of the instrument. Otherwise, electric shock or fire may result. • Be sure to connect a power supply of correct rating. Otherwise, fire may result.

Caution on use	
 DANGER	<ul style="list-style-type: none"> • Be sure to read the instruction manual for standard gases before handling standard gases such as calibration gas to use them properly.
 CAUTION	<ul style="list-style-type: none"> • Leaving the analyzer unused for a long time or restarting it after long-term suspension requires procedures different from normal operation or suspension procedures. Be sure to follow the instructions in each instruction manual. Otherwise, intended performance may not be achieved. Also, accidents or injury may result. • Do not operate the analyzer for a long time with its cover left open. Otherwise, dust, foreign matter, etc. may contaminate on internal walls, thereby causing faults.

Caution on use	
 PROHIBITION	<ul style="list-style-type: none"> • Do not touch the input/output terminals with metal or finger. Otherwise, electric shock or injury may result. • Do not smoke or use flames near the analyzer. Otherwise, fire may result. • Do not allow water to enter the analyzer. Otherwise, electric shock or internal fire may result.

Caution on maintenance and check	
 DANGER	<ul style="list-style-type: none"> • Before performing work with the cover of the analyzer kept open for maintenance and check, be sure to purge completely not only within the analyzer but also measuring gas lines with nitrogen or air. Otherwise, poisoning, fire, or explosion may result due to gas leakage.
 CAUTION	<p>Be sure to observe the following to perform work safely, avoiding electric shock or injury.</p> <ul style="list-style-type: none"> • Remove the watch and other metallic objects before work. • Do not touch the instrument with wet hands. • If the fuse is blown, eliminate the cause and replace it with the one of the same capacity and type. Otherwise, electric shock or accidents may result. • Do not use replacement parts other than those specified by the manufacturer. Otherwise, intended performance may not be achieved. Besides accidents or failures may result. • Dispose replacement parts such as maintenance parts as incombustibles according to the local waste disposal regulations.

Others	
 CAUTION	<ul style="list-style-type: none"> • If the cause of any fault cannot be identified by referring to the instruction manual, be sure to contact your dealer or Fuji's technician in charge of adjustment. Disassembling the instrument carelessly may result in electric shock or injury.

WARRANTY AND MAINTENANCE

1. Scope of application

To use this equipment, the following conditions must be met:

- the use of the equipment incurs no risk of a serious accident even if a failure or malfunction occurs on the equipment, and
- in case of product failure or malfunction, safety measures such as redundant design, prevention of malfunction, fail safe system, foolproof mechanism are provided outside of the equipment.

Be sure to use this instrument under the conditions or environment mentioned in this instruction manual. Please consult us for the use for the following applications:

Radiation-related facilities, systems related to charging or settlement, or other usages which may have large impact on lives, bodies, property, or other rights or interests.

2. Operating conditions and environment

Refer to "Caution on safety" and Section 9, "Specifications".

3. Precautions and prohibitions

Refer to "Caution on safety" and Section 9, "Specifications".

4. Warranty

4-1. Period of warranty

- (1) Warranty period for this product including accessories is one year after delivery.
- (2) Warranty period for the parts repaired by our service providers is six months after the completion of repair.

4-2. Scope of warranty

- (1) If any failure or malfunction attributable to Fuji Electric occurs in the period of warranty, we shall provide the product after repairing or replacing the faulty part for free of charge at the place of purchase or delivery. The warranty does not apply to failure or malfunctions resulting from:
 - 1) inappropriate conditions, environment, handling or usage that is not instructed in a catalog, instruction book or user's manual, or overuse of the product,
 - 2) other devices not manufactured by Fuji Electric,
 - 3) improper use, or an alteration or repair that is not performed by Fuji Electric,
 - 4) inappropriate maintenance or replacement of expendable parts listed in the instruction book or the catalog,
 - 5) damages incurred during transportation or fall after purchase,
 - 6) any reason that Fuji Electric is not responsible for, including a disaster or natural disaster such as earthquake, thunder, storm and flood damage, or inevitable accidents such as abnormal voltage.
- (2) Regardless of the time period of the occurrence, Fuji Electric is not liable for the damage caused by the factors Fuji Electric is not responsible for, opportunity loss of the purchaser caused by malfunction of Fuji Electric product, passive damages, damage caused due to special situations regardless of whether it was foreseeable or not, and secondary damage, accident compensation, damage to products that were not manufactured by Fuji Electric, and compensation towards other operations.

5. Failure diagnosis

Regardless of the time period of the occurrence, if any failure occurs, the purchaser shall perform a primary failure diagnosis. However, at the purchaser's request, Fuji Electric or our service providers shall provide the diagnosis service for a fee. In such a case, the purchaser shall be charged for the service.

6. Service life

This product, excluding limited-life parts and consumable parts, is designed for a service life of 10 years under general operating conditions (with an average ambient temperature of 30°C).

The service life may be shortened depending on operating conditions and environment. To ensure the service life, it is important to perform planned maintenance of the product including limited-life parts and consumable parts.

7. Maintenance plan

Maintenance can be divided into "preventive maintenance" and "corrective maintenance". Preventive maintenance can further classified into "daily inspection" and "periodic inspection". Preventive maintenance is achieved through systematic implementation of "daily inspection" and "periodic inspection".

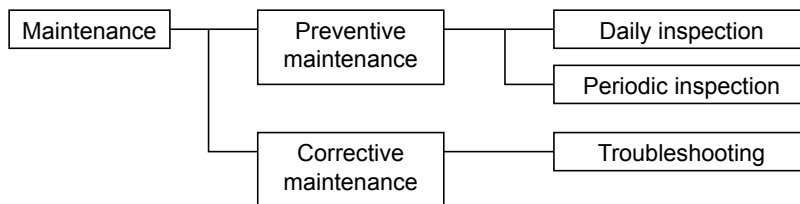

(1) Daily inspection

Be sure to perform daily inspection prior to operation to check for any problem in daily operation. For the specific items of daily inspection, refer to Section 7, "Maintenance".

(2) Periodic inspection

Periodic inspection is to replace limited-life parts before their service lives are over, thus preventing failure. Recommended inspection interval is 6 months to 12 months. If you are using the instrument under harsh environment, we recommend you to shorten the inspection interval. For the specific items of periodic inspection, refer to Section 7, "Maintenance".

(3) Corrective maintenance

Corrective maintenance is a measure to be taken after a trouble has occurred. Refer to Section 7 "Maintenance" and Section 8. "Error messages". If the measures mentioned in this instruction manual do not solve the problem, please contact one of our sales offices or service offices.

8. Limited-life parts and consumable parts

This product contains the following limited-life parts and consumable parts which may affect the service life of the product itself.

(1) Aluminum electrolytic capacitor

- Design life: 5 years under general working conditions (annual average of ambient temperature: 30°C)
- Symptoms when a capacitor loses its capacity: deterioration of power quality, malfunction
- Factors which affect battery life: temperature. The life is shortened by half when the temperature rises by 10°C. (Arrhenius' law)
- Replacement: Estimate the lifetime of capacitor according to your operating environment, and have the capacitor replaced or overhauled at appropriate time, at least once in 10 years.

Do not use capacitors beyond its lifetime. Otherwise, electrolyte leakage or depletion may cause odor, smoke, or fire. Please contact Fuji Electric or its service providers when an overhaul is required.

(2) LCD

- Design life: approx. three years for continuous use
- Symptoms when LCD is depleted: unclear indication, back light not working
- Factors which affect battery life: temperature. The life is shortened by half when the temperature rises by 10°C. (Arrhenius' law)
- Replacement: Estimate the lifetime of built-in battery according to your operating environment, and replace it at appropriate time.

9. Spare parts and accessories

Refer to "Confirmation of delivered equipment" and/or Section 7 "Maintenance" for spare parts and accessories.

10. Period for repair and provision of spare parts after product discontinuation (maintenance period)

The discontinued models (products) can be repaired for 5 years from the date of discontinuation. Also, most spare parts used for repair are provided for five years from the date of discontinuation. However, some electric parts may not be obtained due to their short life cycle. In this case, repair or provision of spare parts may be difficult even in the above period.

Please contact one of our sales offices or service offices for further information.

CONTENTS

PREFACE.....	i
CAUTION ON SAFETY	ii
WARRANTY AND MAINTENANCE	v
CONTENTS	viii
1. OVERVIEW.....	1
2. NAME OF DELIVERED ITEMS AND EACH PARTS	2
2.1 Confirmation of delivered items	2
2.2 Name and description of analyzer.....	4
3. INSTALLATION	6
3.1 Installation conditions.....	6
3.2 Installation.....	7
3.2.1 Installation of analyzer main frame	7
3.3 Piping.....	9
3.4 Sampling.....	12
3.4.1 Conditions of sampling gas.....	12
3.4.2 Sampling gas flow.....	12
3.4.3 Preparation of standard gas.....	12
3.4.4 Purging of instrument inside	12
3.4.5 Pressure at sampling gas outlet.....	13
3.4.6 Example configuration of gas sampling system	13
3.5 Wiring.....	14
<Horizontal type>	
(1) Power supply.....	15
(2) Analog output signal	16
(3) O ₂ sensor input	17
(4) Contact input/output (DIO).....	18
(5) Communication.....	19
<Vertical type>	
(1) Power supply.....	20
(2) Analog output signal (A/O).....	21
(3) O ₂ sensor input (A/I).....	21
(4) Contact input (DI)	21
(5) Contact output (DO).....	21
(6) External connection diagram	22
(7) Description on terminal block.....	23
3.6 Timing of contact output for calibration	27

4.	OPERATION	28
4.1	Preparation for operation	28
4.2	Warm-up operation and regular operation	28
5.	DESCRIPTION OF DISPLAY AND OPERATION PANELS.....	29
5.1	Name and description of operation panel	29
5.2	Overview of display and operation panels.....	30
5.3	Outline of display screen.....	31
5.4	Basic operation.....	34
6.	SETTING AND CALIBRATION.....	35
6.1	Switch of range	35
6.1.1	Setting of range switch mode.....	35
6.1.2	Manual range switch.....	36
6.2	Calibration setting.....	37
6.2.1	Setting of calibration concentration.....	37
6.2.2	Setting of manual zero calibration.....	39
6.2.3	Setting of calibration range.....	41
6.2.4	Setting of auto calibration component/range	42
6.3	Alarm setting.....	44
6.3.1	Setting of alarm values	44
6.3.2	Hysteresis setting	46
6.3.3	Peak alarm setting (Only for horizontal type)	47
6.4	Setting of auto calibration.....	49
6.4.1	Auto calibration	49
6.4.2	Forced run/stop of auto calibration.....	52
6.5	Setting of auto zero calibration	54
6.5.1	Auto zero calibration	54
6.5.2	Forced run/stop of auto zero calibration.....	56
6.6	Parameter setting.....	58
6.7	Maintenance mode.....	64
6.7.1	Sample switch setting	69
6.8	Manual calibration procedure	73
6.8.1	Manual zero calibration	73
6.8.2	Manual span calibration.....	74
7.	MAINTENANCE	75
7.1	Daily check	75
7.2	Daily check and maintenance procedures.....	75
7.3	Long term maintenance.....	76
7.4	Cleaning of sampling cell	77
7.4.1	Disassembly and assembly of sampling cell.....	77
7.4.2	How to clean sampling cell.....	79

7.5	Replacement of fuse.....	79
8.	ERROR MESSAGE.....	80
9.	SPECIFICATIONS	83
9.1	General specifications	83
9.2	Code symbols.....	87
9.3	Outline diagram.....	91

1. OVERVIEW

This instrument measures the concentration of NO, SO₂, CO₂ and CO contained in sample gas on the principle that different atomic molecules have an absorption spectrum in the wave band of infrared rays, and the intensity of absorption is determined by the Lambert-Beer law.

Since this instrument incorporates a compact O₂ sensor, it allows measuring up to 2 components simultaneously by using the built-in O₂ sensor (up to 1 components if O₂ sensor is excluded).





Furthermore, use of a microprocessor and large sized liquid crystal display realizes improvement of operability, accuracy and multi-functions.

Optimum use as an analyzer unit of a measurement system for gas separation process and atmospheric environment measurement and combustion exhaust gas from refuse incinerators and boilers, or gas from various industrial furnaces.



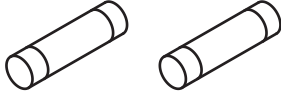
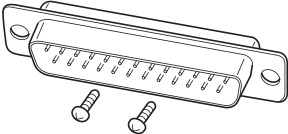

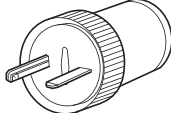
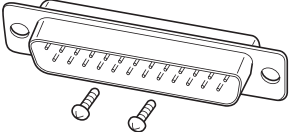
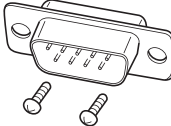
2. NAME OF DELIVERED ITEMS AND EACH PARTS

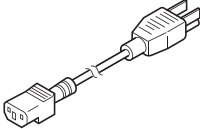
2.1 Confirmation of delivered items

<Horizontal type>

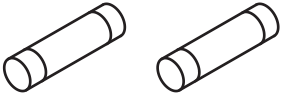
Analyzer: 1 unit		
Fuse: 2 pcs		Standard: IEC127-2 Size: $\phi 5 \times 20\text{mm}$ Rating: 250V/2A delay type Part No.: R75796N17
Analog output connector: 1 Fixing screws: 2		25 pin D-sub connector (male) Part No.: R77256N262 $M2.6 \times 4\text{mm}$
Instruction manual (this manual): 1 copy (INZ-TN1ZPG-E)		
External input connector: 1 (External O ₂ analyzer and External zirconia O ₂ analyzer are specified)		Part No.: R77240N35
Digital input/output connector: 3 max. with the number of DIO Fixing screws: 6 max. (When digital input/output function is specified)		25 pin D-sub connector (male) Part No.: R77256N262 $M2.6 \times 4\text{mm}$ Max. 3 sets
RS-485 connector: 1 Fixing screws: 2 (When provided with communication function)		9 pin D-sub connector (male) Part No.: R77256N284 $M2.6 \times 4\text{mm}$
Ferrite core: 1 For power cable (When terminal block for power supply is specified)		
Power supply cord: 1 (When power inlet is specified)		

<Vertical type>

<p>Analyzer: 1 unit</p>		
<p>Fuse: 2 pcs</p>		<p>Standard: IEC127-2 Size: $\phi 5 \times 20\text{mm}$ Rating: 250V/2A delay type Part No.: R75796N17</p>
<p>Instruction manual (this manual): 1 copy (INZ-TN1ZPG-E)</p>		
<p>Ferrite core: 1 For power cable</p>		<p>Part No.: R79181N14</p>
<p>Ferrite core: 3 For digital I/O cable</p>		<p>Part No.: R79181N14</p>

2.2 Name and description of analyzer

<Horizontal type>

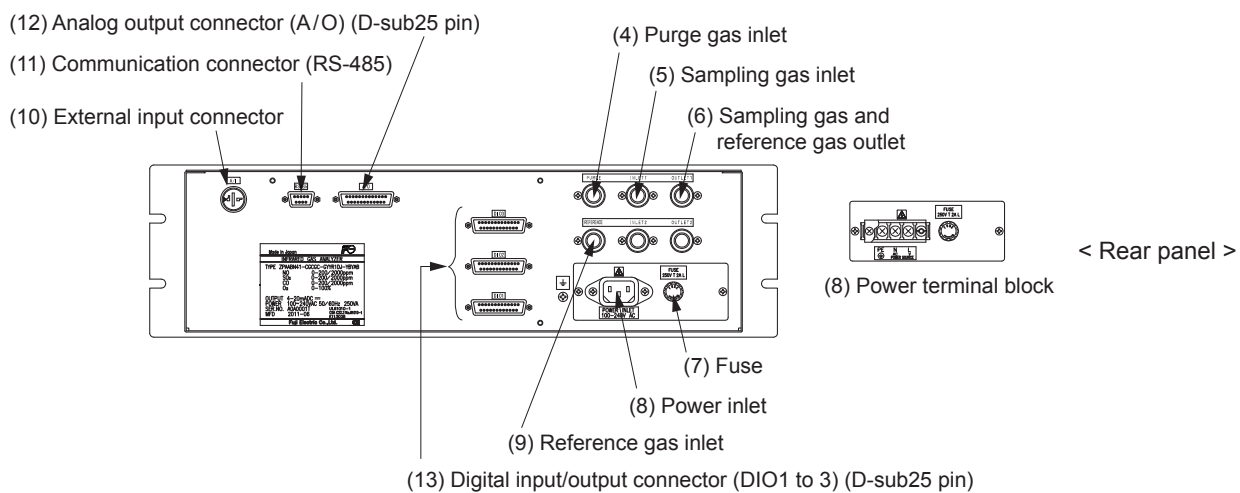
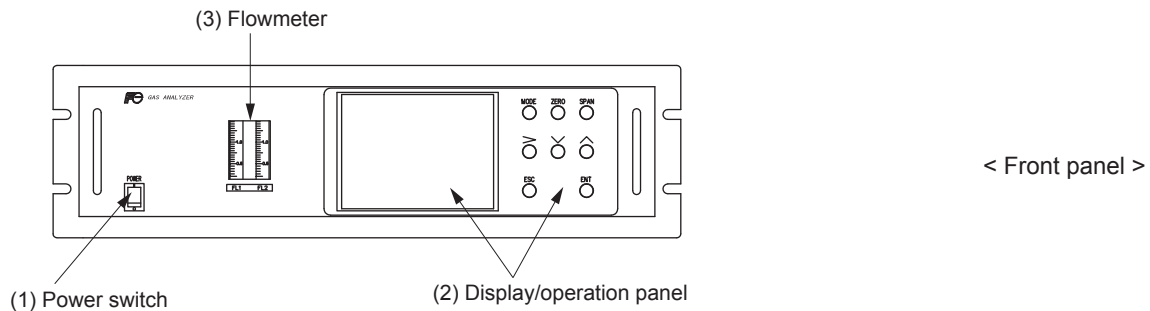

Name	Description	Name	Description
(1) Power switch	Used for ON/OFF the analyzer.	(9) Reference gas inlet	For connecting to the reference gas tube.
(2) Display/operation panel	Liquid crystal display and keys for setting various functions.	(10) External input connector	For connecting to the output of externally installed O ₂ analyzer.
(3) Flow meter	For checking the flow rate of sampling gas and reference gas.	(11) Communication connector	RS-485 connector for communication.
(4) Purge gas inlet	For connecting to the purge gas tube.	(12) Analog output connector (D-sub25 pin)	Connector for the analog output
(5) Sampling gas inlet	For connecting to the measuring gas tube.	(13) Digital input/output connector (D-sub25 pin)	Connector for the digital input/output
(6) Sampling gas and reference gas outlet	For connecting to the exhaust line.		
(7) Fuse	Fuse inside		
(8) Power supply	For connecting to the power supply line.		

<Vertical type>

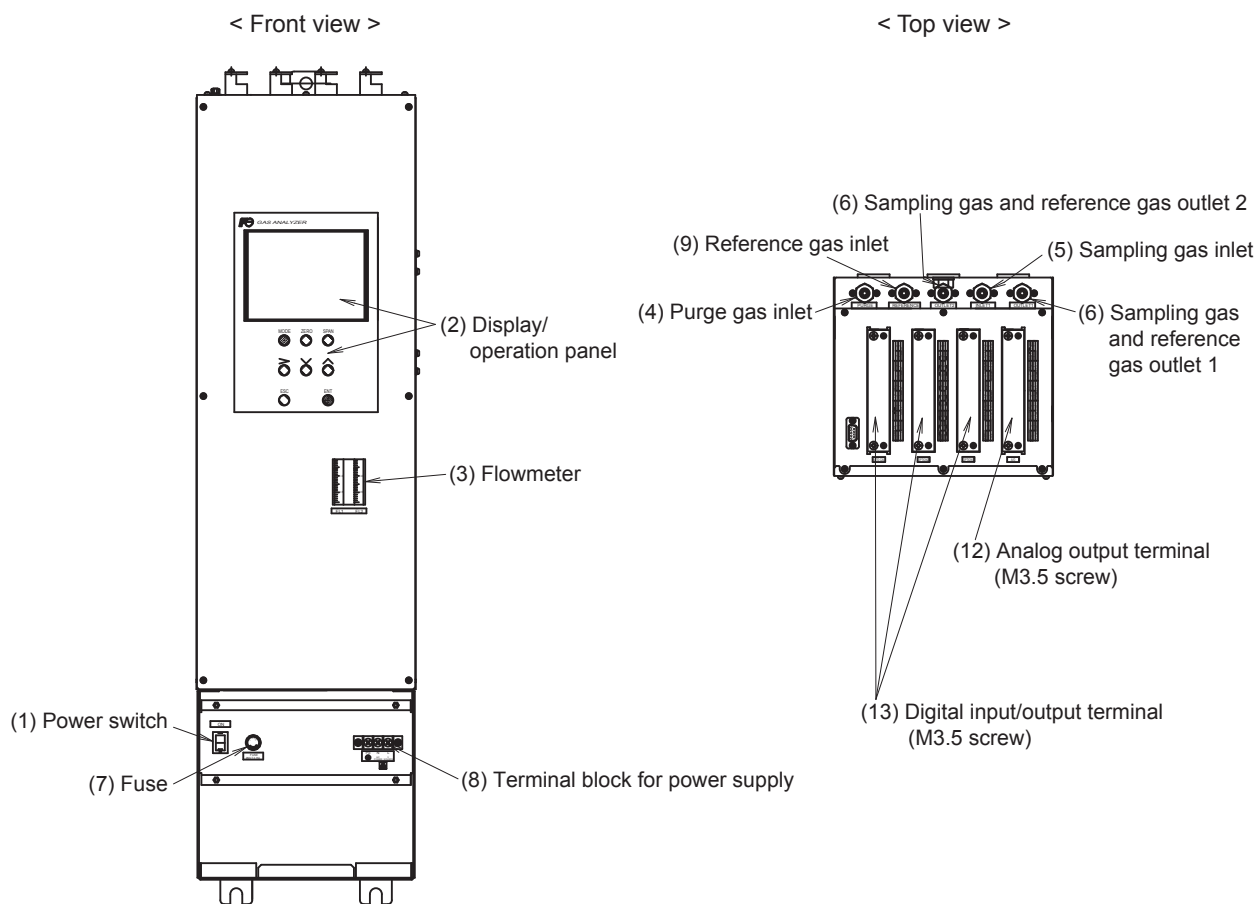

Name	Description	Name	Description
(1) Power switch	Used for ON/OFF the analyzer.	(7) Fuse	Fuse inside
(2) Display/operation panel	Liquid crystal display and keys for setting various functions.	(8) Terminal block for power supply	Screw terminals for connecting to the power supply line.
(3) Flow meter	For checking the flow rate of sampling gas and reference gas.	(9) Reference gas inlet	For connecting to the reference gas tube.
(4) Purge gas inlet	For connecting to the purge gas tube.	(12) Analog output terminal (M3.5 Screw)	Screw terminals for the analog input (external O ₂ sensor signal) and output
(5) Sampling gas inlet	For connecting to the measuring gas tube.	(13) Digital input/output terminal (M3.5 Screw)	Screw terminals for the digital input/output
(6) Sampling gas and reference gas outlet	For connecting to the exhaust line.		

3. INSTALLATION

DANGER

This unit is not explosion-proof type. Do not use it in a place with explosive gases to prevent explosion, fire or other serious accidents.

CAUTION

- Entrust the installation, movement or re-installation to a specialist or the supplier. A poor installation may cause accidental tipover, electric shock, fire, injury, etc.
- The gas analyzer is heavy. It should be installed with utmost care. Otherwise, it may tipover or drop, for example, causing accident or injury.
- For lifting the gas analyzer, be sure to wear protective gloves. Bare hands may invite an injury.
- This unit should be installed in a place which conforms to the conditions noted in the instruction manual. Otherwise, it may cause electric shocks, fire or malfunction of the unit.
- During installation work, care should be taken to keep the unit free from entry of cable chips or other foreign objects. Otherwise, it may cause fire, trouble or malfunction of the unit.

3.1 Installation conditions

To install the analyzer for optimum performance, select a location that meets the following conditions;

- (1) This instrument is system built in type. This instrument should be used while embedded in a panel, locker, or enclosure of steel sheet.
Keep a minimum clearance of 10 cm above the analyzer for heat dissipation. The same clearance is required for each analyzers when you install several units on a multistage rack.
- (2) Use this instrument indoors.
- (3) A vibration-free place
- (4) A place which is clean around the analyzer.
- (5) Power supply
 - Rated voltage : 100V to 240V AC
 - Operating voltage : 85V to 264V AC
 - Rated frequency : 50/60 Hz
 - Power consumption : 100 VA max.
- (6) Operation conditions
 - Ambient temperature : -5° to 45° C (max. 40° C when the power supply is more than 200V AC)
 - Ambient humidity : 90 % RH or less, no condensation
- (7) Maintenance space
When analyzer is installed by itself, please make sure to keep the space shown in the dimension of the figure for maintenance. In case analyzer is installed as an unit, please refer to the instruction manual of the analyzer unit.
- (8) A breaker that meets IEC60947-1 and IEC60947-3 should be included in the installation.
- (9) A breaker should be installed near the analyzer where an operator can access it.
- (10) A label that clearly identifies the breaker should be placed on it.
- (11) The breaker rating should meet the analyzer rating max 2A and a breaker should conform to all necessary approvals.

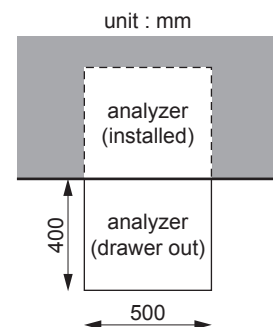

3.2 Installation

3.2.1 Installation of analyzer main frame

Installation methods for the analyzer main unit is shown below.

<Horizontal type>

(Unit : mm)

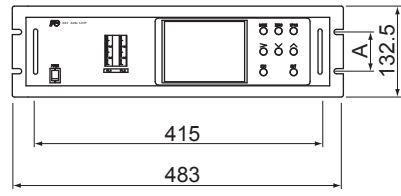
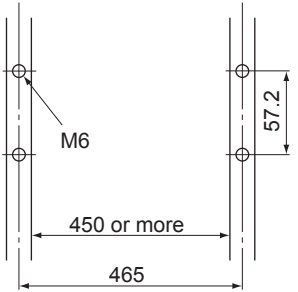
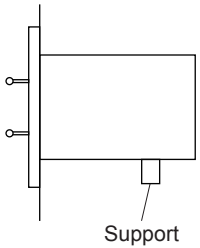
Type	External dimensions	Mounting dimensions	Mounting method
19-inch rack mounting	 <p>"A" : 57.2 (EIA)</p>		

- Note)
- The analyzer weight must be supported at the bottom of the casing.
 - The analyzer should be installed in a place where ambient temperature is within -5 to 45°C (max. 40°C when the power supply is more than 200V AC), and temperature fluctuation during using is minimum.
 - Where vibration is unavoidable, protect the analyzer from vibrating.
For example, install rubber material around the case to isolate vibration from the support structure.

<Vertical type>

(Unit: mm)

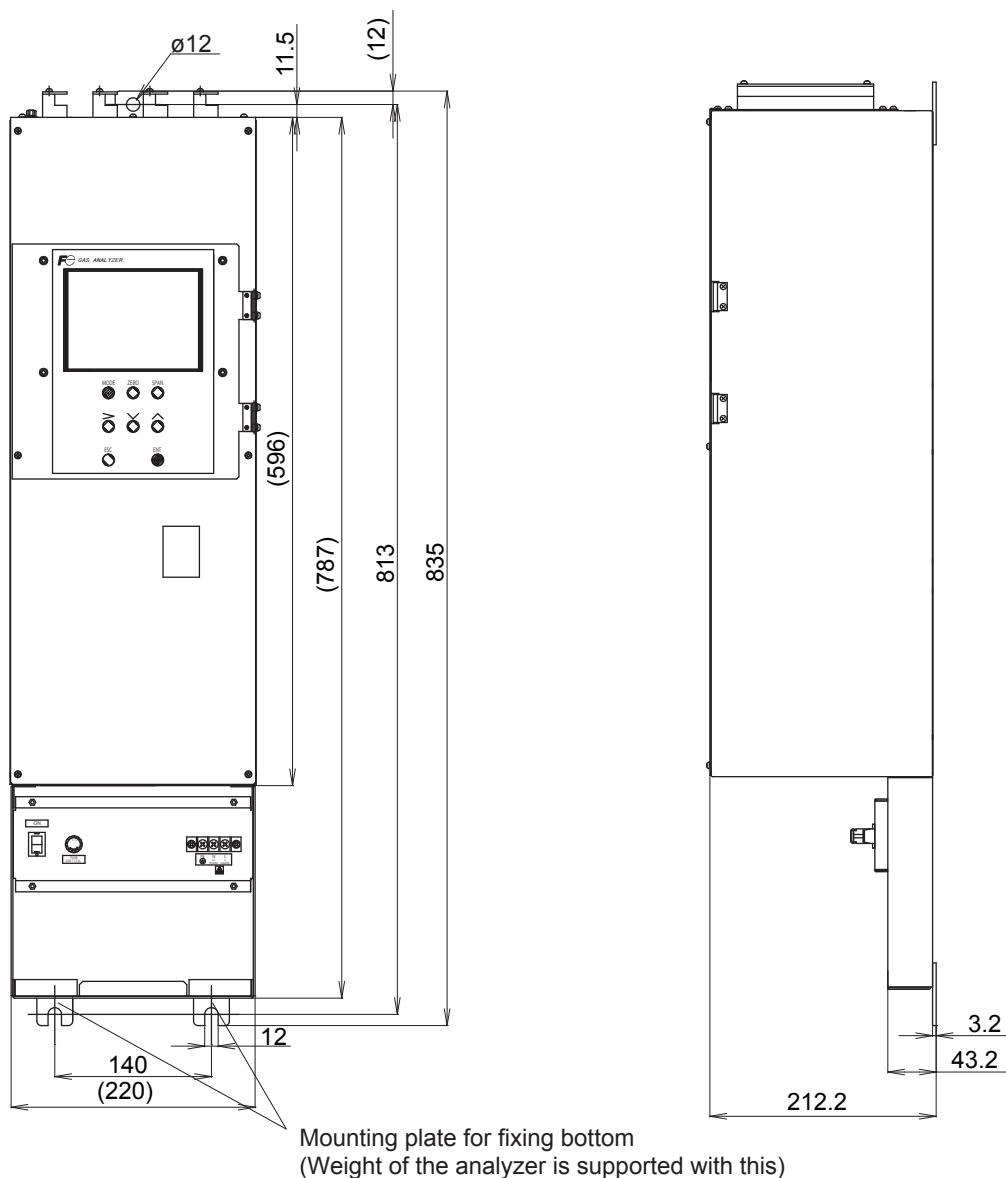

Note) Check and maintenance of the analyzer may be carried out with the front cover detached. For installation, the weight of the analyzer should be supported with the bottom of the case.
Do not install the analyzer at the place which is exposed to direct sunlight.
The analyzer should be installed at a place where ambient temperature is within -5 to 45°C and temperature fluctuation during use is minimum.

3.3 Piping

⚠ CAUTION

In addition to a sample/reference gas inlet and outlet, there is a purge gas inlet at the rear panel of the analyzer.

When improper connection is carried out here, combustible gas, poisonous gas, and explosive fumes may be accumulated into the analyzer.

Be careful of a connection place in the rear panel of piping connection.

Observe the following when connecting the gas tube.

- Piping should be connected to the gas inlets and outlets at the rear panel of the analyzer.
- Use a corrosion resistant tube of Teflon, stainless steel or polyethylene to connect the instrument to a sampling system. Even if there is a danger of corrosion, refrain from using a tube of rubber or soft vinyl. The instrument provides inaccurate indication due to gas absorption by piping materials.
- Pipe connection port is Rc1/4 female thread (or NPT1/4). Piping should be cut as short as possible for a quick response. About 4 mm inner diameter is recommended.
- Entry of dust into the instrument may result in defective operation. Use a clean piping and coupling.

<Horizontal type>

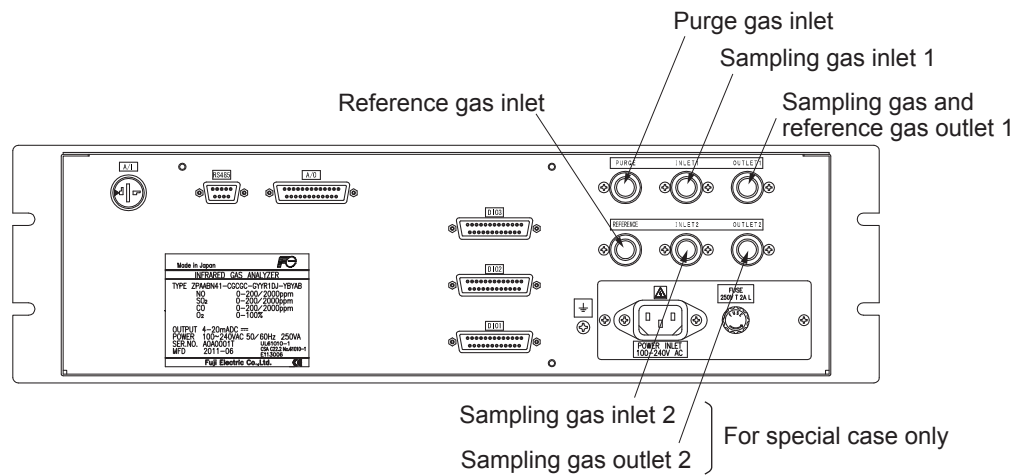

<Vertical type>

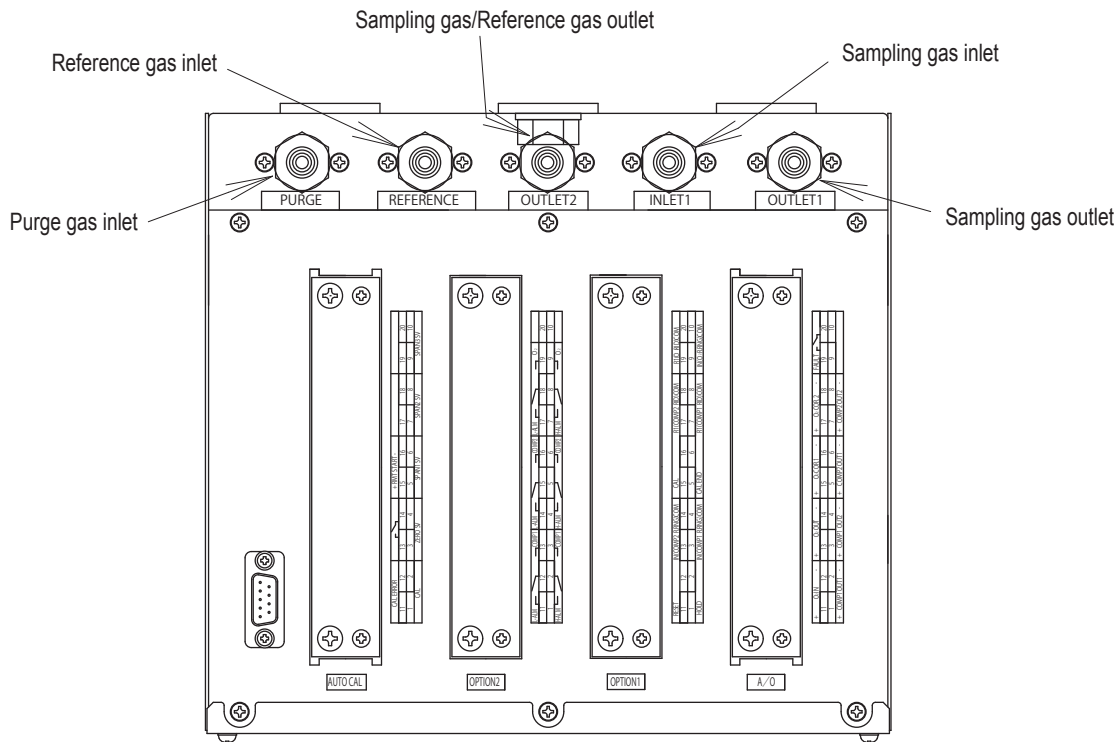

- Sample gas inlet: Attach the gas tube to introduce gas to be measured such as one that has completed dehumidification process and standard gases for zero and span calibration to this inlet.
 Gas flow to be introduced should be constant within the range of 1.0 L/min \pm 0.2 L/min.
- Reference gas inlet: inlet for reference gas used in sample switching system. Use dry air, dry N₂, sample gas, or ambient air after preprocessing such as dehumidification and component elimination. Air flow rate should be constant within the range of 1.0 L/min \pm 0.2 L/min.
- Sample gas outlet/Reference gas outlet (For horizontal type: 1 port, for vertical type: 2 ports):
 Exhaust measured gas through the outlet. Attach the tube to exhaust measured gas outdoors or to the atmosphere.
 Note that the gas to be exhausted from the outlet is a mixture of sample gas and reference gas.
- Purge gas inlet: It is used for purging the inside of the total gas analyzer.
 Use dry gas N₂ or instrumentation air for purge gas. (Flow rate is 1L/min or more, and dust or moisture/mist are unallowable.)

Internal piping diagram

<Horizontal type>

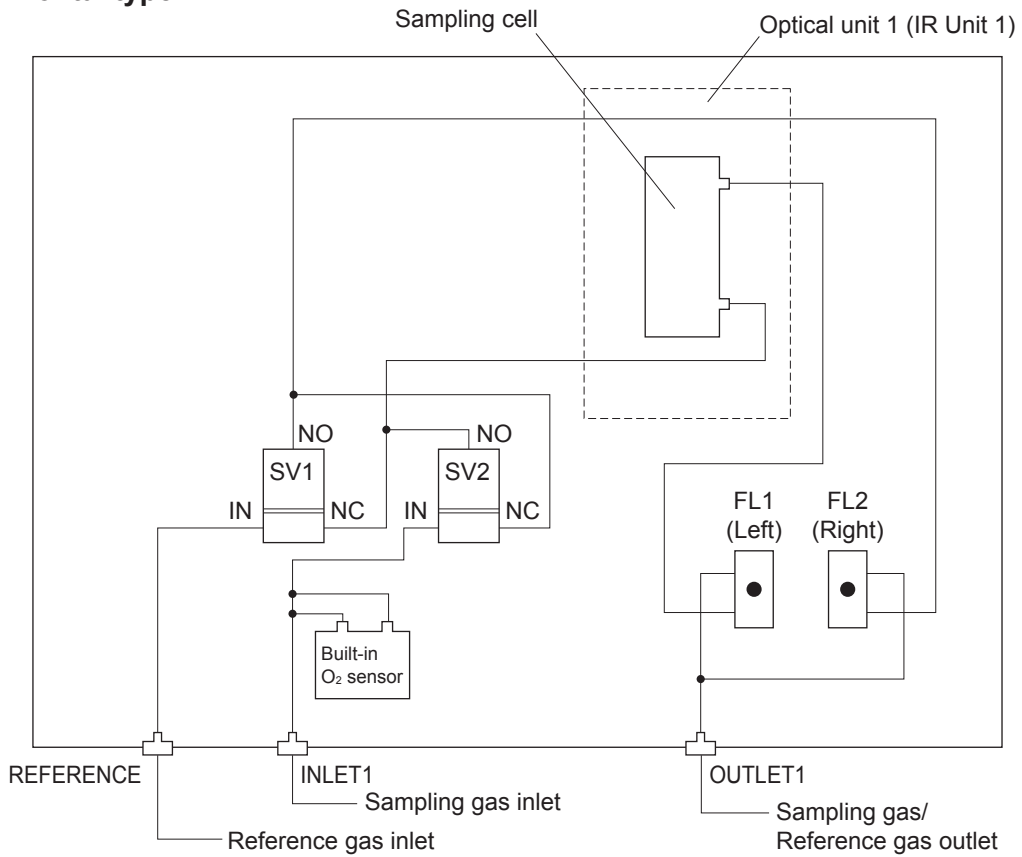

<Vertical type>

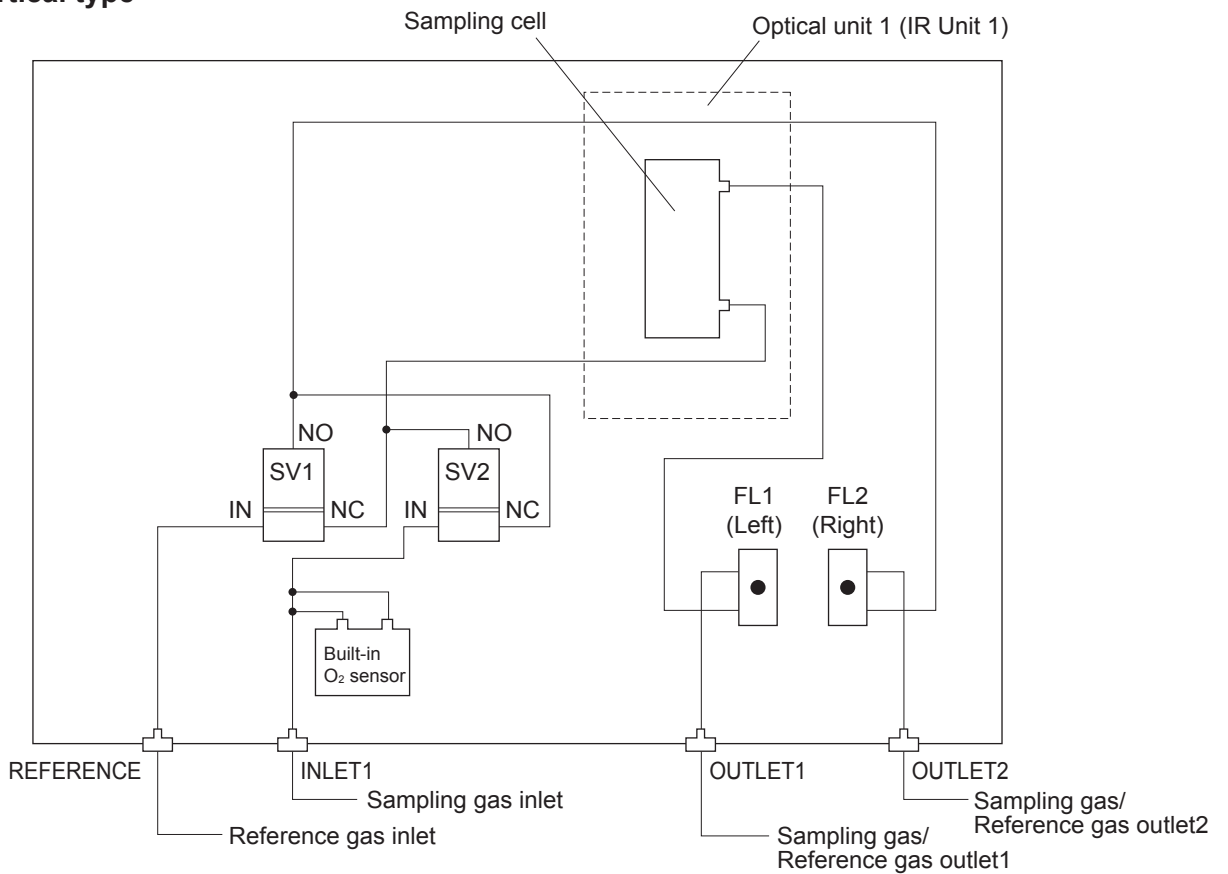

3.4 Sampling

3.4.1 Conditions of sample gas

- (1) Dust contained in the sample gas should be completely removed with a filter. For the final stage filter, use a filter that allows removing dust particles of $0.3\mu\text{m}$.
- (2) Dew point of the sample gas must be lower than the ambient temperature to avoid occurrence of drain in the gas analyzer. If vapor is contained in the sample gas, dew point should be lowered to 2°C by using a dehumidifier.
- (3) If SO_3 mist is contained in the sample gas, use a mist filter or cooler to remove SO_3 mist. Other mists should be removed by using a mist filter or gas dryer.
- (4) Corrosive gases such as Cl_2 , F_2 and HCl , if they are contained in the sample gas in considerable amounts, will shorten the life of component parts.
- (5) Temperature of the sample gas should be within 0 to 50°C . Pay attention not to flow hot gas directly into the instrument.

3.4.2 Sample gas flow

Flow of sample gas should be $1.0\text{L}/\text{min} \pm 0.2\text{L}/\text{min}$.

Avoid flow fluctuation during measurement.

Observe the flow reading by a flowmeter provided as shown in the example of the sampling system configuration (Section 3.4.6).

3.4.3 Preparation of standard gas

Routine calibration is required by standard gas for keeping this instrument under normal operation condition (once a week). Prepare a standard gas cylinder for zero calibration and span calibration.

	Analyzer without O_2 measurement	Analyzer with built-in O_2 sensor	Analyzer with external zirconia O_2 sensor
Zero gas	N_2 gas	N_2 gas	Dry air
Span gas other than for O_2 measurement	Gas with concentration of 90 to 100% of its measuring range, balance N_2 .	Gas with concentration of 90 to 100% of its measuring range, balance N_2 .	Gas with concentration of 90 to 100% of its measuring range, balance N_2 .
Span gas for O_2 measurement	—————	Gas with concentration of 90 to 100% of its measuring range or atmospheric air (21% O_2).	O_2 gas of 1 to 2%

3.4.4 Purging of instrument inside

The inside of instrument need not be purged generally except for the following cases.

- (1) A combustible or a explosive component is contained in the sample gas.
- (2) Corrosive gas is contained in the atmospheric air at the installation site.
- (3) The same gas as the sample gas component is contained in the atmospheric air at the installation site.

In such cases as above, the inside of analyzer should be purged with the air for instrumentation or dry N_2 .

Purging flow rate should be about $1\text{L}/\text{min}$.

Purging gas, if used, must not contain dust or moisture.

3.4.5 Pressure at sample gas outlet

Pressure at the sample gas outlet should be adjusted to the atmospheric pressure.

3.4.6 Example configuration of gas sampling system

The following illustrates a typical system configuration for 2 component gas measurement for monitoring combustion exhaust gas from boiler, refuse incinerator, etc.

Contact Fuji Electric for system configuration matching the particular use or further information.

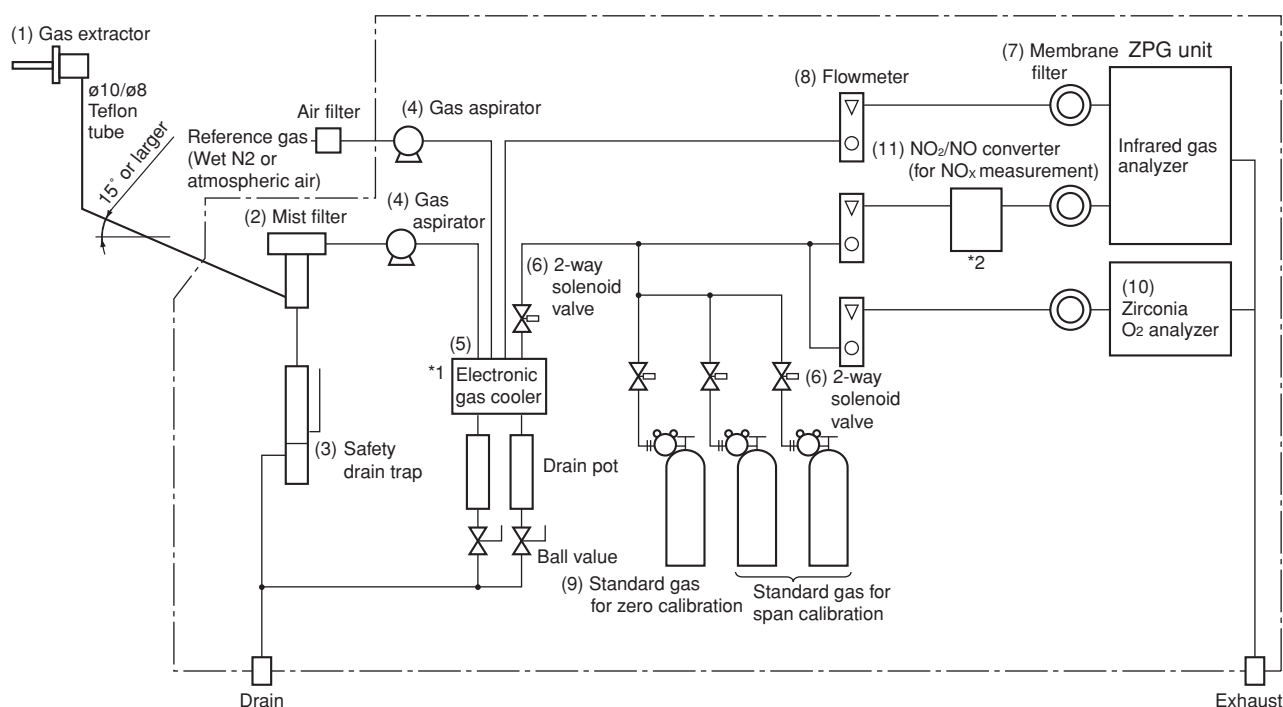

- *1) Be sure to remove the moisture to be temperature 5°C or lower from measuring gas by electronic cooler and water concentration should be equalized in reference gas and sample gas.
- *2) Be sure to use NO₂/NO converter in case of measuring NO_x.

Name	Description	Name	Description
(1) Gas extractor	Gas extractor with a heating type stainless steel filter of standard mesh 40µm	(8) Flowmeter	Adjusts and monitors the flow rate of the sample gas, reference gas and standard gas for calibration.
(2) Mist filter	Removes drain, mist, and dust.	(9) Standard gas	Standard gas used for calibrating zero and span of the analyzer, depending on the measured component.
(3) Safety drain trap	The safety drain trap is divided into two spaces for positive and negative pressure. It monitors and adjusts the sample gas pressure.		
(4) Gas aspirator	For aspiration of the sample gas and reference gas.	(10) Zirconia O ₂ analyzer	External zirconia oxygen sensor used for measuring the oxygen concentration in sample gas. (This is not necessary in case when O ₂ sensor is built-in.)
(5) Electronic gas cooler	Dries the moisture in the sample gas and reference gas to a dew point of approx. 2°C.		
(6) Solenoid valve	Used for flowing the standard gas.		
(7) Membrane filter	PTFE filter used to eliminate fine dust particles.	(11) NO ₂ /NO converter	Added to NO _x analyzer. A special catalyst material for efficient conversion of NO ₂ gas to NO is used.

3.5 Wiring

⚠ CAUTION

- Be sure to turn off the power before installing wiring. Otherwise, electric shock may result.
- Be sure to perform protective earth connection. Otherwise, electric shock or failure may result.
- Select a proper wiring material that satisfies the ratings of the instrument. Otherwise, electric shock or fire may result.
- Be sure to connect a power supply of correct rating. Otherwise, fire may result.

⚠ CAUTION

⚡ Electric Shock

Please be sure to make ground (grounding) connection for safety.

<Horizontal type>

The power terminal block or the power inlet and external input/output connector is provided at the rear panel. Refer to the following.

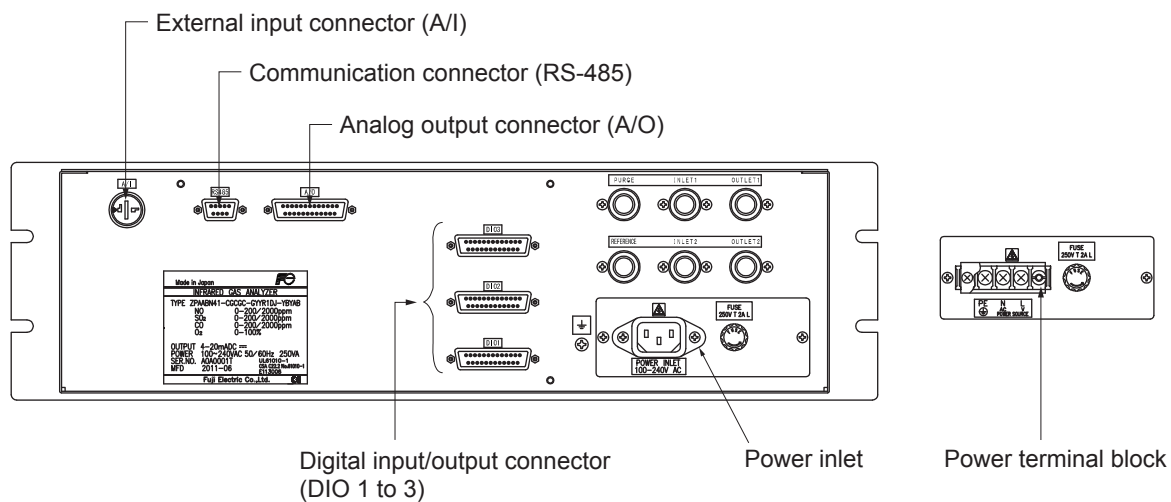

(1) Power supply

Connect the given power supply to the power terminal, and connect the ground wire to the grounding terminal. Be sure to perform protective earth connection. Use solderless terminals (for M4) for connection to the terminals (power and earth).

Please install an accessory ferrite core (To the power supply terminal block side) on the power supply wiring line of ZPG. Applicable line diameter $\phi 9.5$ to $\phi 10.5$.

<Terminal block for power supply>

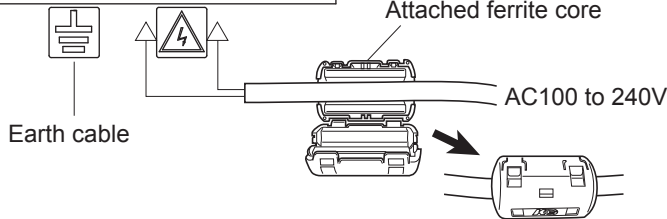
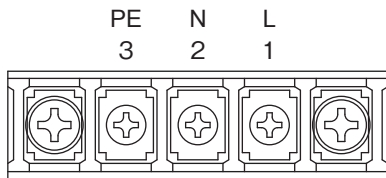

<Power inlet>

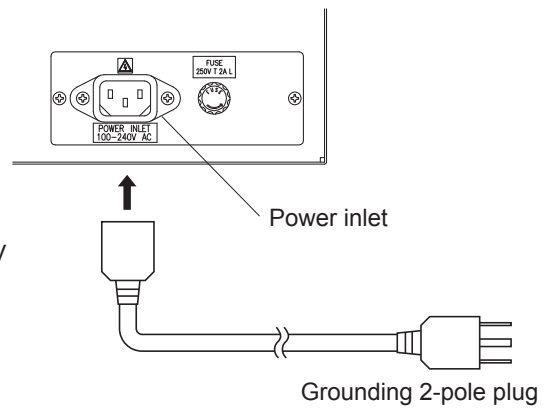

⚠ CAUTION

After the wiring work, be sure to put the protective cover on the terminal blocks to ensure safety.

When noise source is in the vicinity

- Avoid installing this instrument near an electrical unit (high frequency furnace or electric welder) that generates much electrical noise. If using the instrument near such a noise generating unit is unavoidable, use a different power line to avoid noise.
- Mount a noise suppressor such as varistor or spark quencher as shown at right figure to the noise generating unit when noise is generated from relays or solenoid valves. Mount the suppressor near the noise generating source, or it will have no effect.

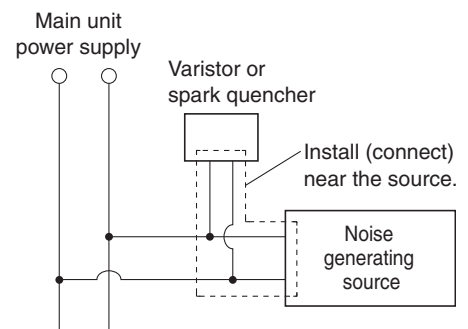

(2) Analog output signal: Analog output connector (A/O)

Output signal : 4 to 20 mA DC or 0 to 1 V DC (selected when ordering)

Minus lines for the signal are common. And they are insulated from the ground and internal circuit.

Allowable load: 4 to 20 mA DC, 550Ω or less

0 to 1 V DC, 100kΩ or more

< Analog output > A/O connector

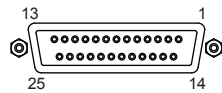

D-sub 25-pin female

Note) Display Ch number is same as the AO number under standard specifications.

- ① ————— AO1+
- ⑭ ————— AO1-
- ② ————— AO2+
- ⑮ ————— AO2-
- ③ ————— AO3+
- ⑯ ————— AO3-
- ④ ————— AO4+
- ⑰ ————— AO4-
- ⑤ ————— NC (No Connection)
- ⑱ ————— NC
- ⑥ ————— NC
- ⑲ ————— NC
- ⑦ ————— NC
- ⑳ ————— NC
- ⑧ ————— NC
- ㉑ ————— NC
- ⑨ ————— NC
- ㉒ ————— NC
- ⑩ ————— NC
- ㉓ ————— NC
- ⑪ ————— NC
- ㉔ ————— NC
- ⑫ ————— NC
- ㉕ ————— NC
- ⑬ ————— NC

The analog output signals of the instrument are not isolated individually. It is recommended to isolate the signals individually to eliminate the interference from the unnecessary signals or the effect of external interference, especially if the cable exceeds 30 meters or leads to outdoors.

(3) O₂ sensor input: External input connector (A/I)

Input signal:

External zirconia O₂ analyzer : Zirconia O₂ sensor signal (Fuji ZFK7 output)

External O₂ analyzer : 0 to 1 V DC (DC input resistor of 1MΩ or more)

< External input > A/I connector (O₂ sensor input)

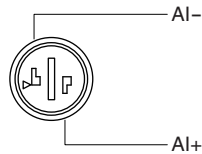

- It is used when the external zirconia O₂ analyzer or the external O₂ analyzer is specified as ordered.
- Connect the dedicated connector (accessory) to the output of the external Zirconia analyzer or the external O₂ analyzer (received separately).
- In case of an external O₂ analyzer, input a signal of 0 to 1 V DC with respect to O₂ full scale of the analyzer. The O₂ concentration display, output, and O₂ correction can be performed.
- Do not connect when the built-in O₂ analyzer is installed.

O₂ sensor input is not isolated. It is recommended to isolate when an external O₂ analyzer is installed apart from this analyzer. Zirconia O₂ sensor (Fuji ZFK7) should be installed at a location that is as close to this instrument as possible.

* How to connect the O₂ signal to the dedicated connector (accessory).

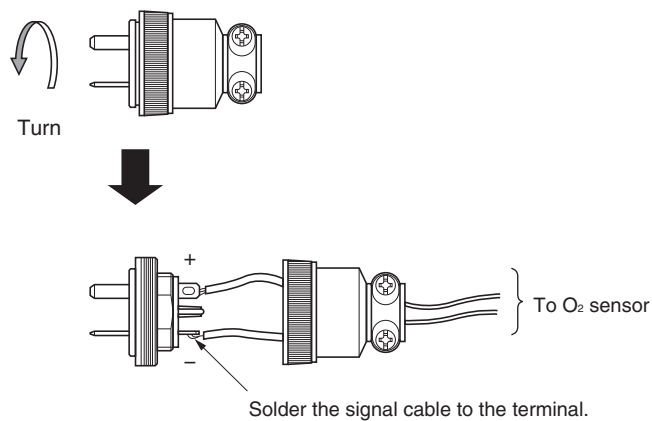

(4) Contact input/output (DIO): digital input/output connector (DIO1 to 3)

Contact input signal : Voltage is applied from the external 12 to 24 V DC, max 15mA
Photo-coupler isolation (from each DI and ground)

Contact capacity : C contact relay output 24V/1A AC/DC resistive load

< Digital input/output > Connector for DIO 1 to 3 (option)

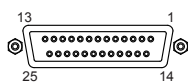

D-sub 25-pin female

Note) DIO 1 to 3 have the same internal circuit of the connector.

Contents of digital input signal

DI1	Remote hold
DI2	Average value reset
DI3	A. cal. start
DI4	A. zero. cal. start
DI5	Remote range Ch1
DI6	Remote range Ch2
DI7	Remote range Ch3
DI8	Remote range Ch4
DI9	Remote range Ch5

Allocation table of digital input signal

22th digit →	A	B	C	D	E	F	G	H	Y
DI1	○	○	○	○	○	○	○	○	
DI2	○	○	○	○	○	○	○	○	
DI3				○					
DI4		○			○				
DI5				○		○			
DI6				○*		○*	○*	○*	
DI7				○*		○*	○*	○*	
DI8				○*		○*	○*	○*	
DI9				○*		○*	○*	○*	

○ sign shows the function is valid.

* : The function might be invalid depending on the number of measurable components.

For example: DI5 corresponds to 1st component, DI6 corresponds to 2nd components.

Contents of digital output signal

22th digit →	Independent on the number of component	1-component analyzer		2-component analyzer
		A,C	B,E	D,F,G,H
DO1	Instrument error	Instrument error	Instrument error	Instrument error
DO2	Calibration error	Calibration error	Calibration error	Calibration error
DO3		A.cal.status	(A.cal.status)	(A.cal.status)
DO4		For zero gas	(For zero gas)	(For zero gas)
DO5		For span gas Ch1	(For span gas Ch1)	(For span gas Ch1)
DO6	(Alarm1)	(Alarm1)		(For span gas Ch2)
DO7	(Alarm2)	(Alarm2)		
DO8	(Alarm3)	(Alarm3)		
DO9	(Alarm4)	(Alarm4)		(Range identification Ch1)
DO10	(Alarm5)	(Alarm5)	Range identification Ch1	(Range identification Ch2)
DO11			(Alarm1)	(Alarm1)
DO12			(Alarm2)	(Alarm2)
DO13			(Alarm3)	(Alarm3)
DO14			(Alarm4)	(Alarm4)
DO15			(Alarm5)	(Alarm5)

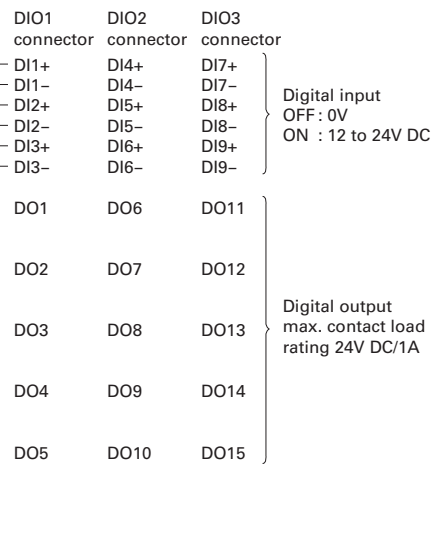

Digital input
OFF : 0V
ON : 12 to 24V DC

Digital output
max. contact load
rating 24V DC/1A

- Isolated output (from each DO and ground)

To avoid external interference, wiring of analog output signal, O₂ sensor input and contact input should be run separately from that of power supply and contact output.

Note) To avoid the effect of noise generated from external units, be sure to ground the analyzer main unit and use properly shielded cables.

(5) Communication: RS-485 connector

< RS-485 connector >

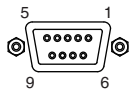

D-sub 9-pin female

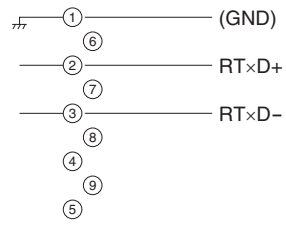

<Vertical type>

(1) **Power supply:** placed on the lower part of the analyzer.

Connect designated cable to the power terminal and a grounding wire to the grounding terminal (P). Class D grounding work is required. Use solderless terminals for M4.

Applicable cable size for power supply is between $\phi 9.5$ to $\phi 10.5$.

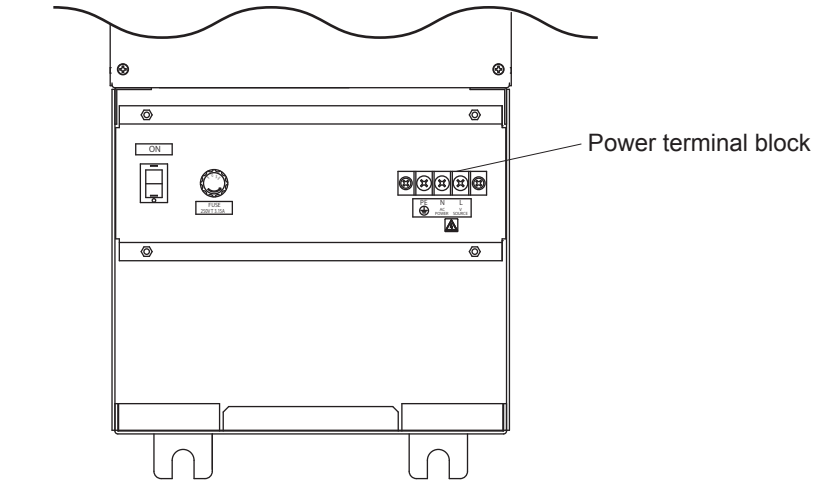

<Terminal block for power supply>

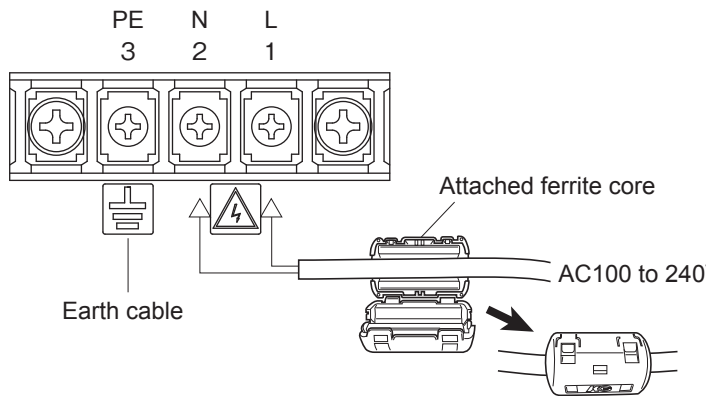

CAUTION

After the wiring work, be sure to replace the protective cover for the terminal blocks to assure safety.

When noise source is in the vicinity

- Avoid installing this instrument near an electrical unit (high frequency furnace or electric welder) that generates much electrical noise. If using the instrument near such a noise generating unit is unavoidable, use a different power line to avoid noise.

- Mount a noise suppressor such as varistor or spark quencher as shown at right figure to the noise generating unit when noise is generated from relays or solenoid valves. Mount the suppressor near the noise generating source, or it will have no effect.

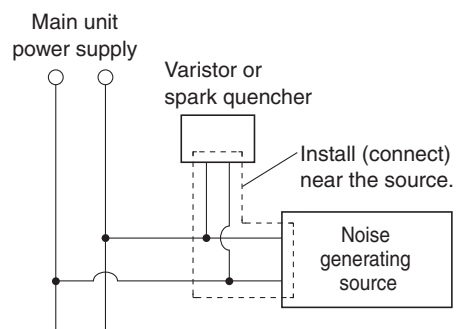

Optimum wire diameter for each input/output terminal is from AWG20 to AWG18.

(2) Analog output signal (A/O): A/O (1) to (8), (13) to (18)

Output signal : 4 to 20 mADC or 0 to 1 VDC (selected when ordering)

Non-insulated output

Allowable load : 4 to 20 mADC, 550Ω or less

0 to 1 VDC, 100kΩ or more

- Analog output is provided from each terminal corresponding to the channel displayed in the measurement screen.

All of analog output signals for the instrument are not isolated. It is recommended to isolate signals individually to prevent interference from unnecessary signals or to prevent external interference, especially leading the cable of more than 30 meters or to outdoor.

(3) O₂ sensor input (A/I): A/O (11) – (12)

Input signal:

External zirconia O₂ analyzer : Zirconia O₂ sensor signal (Fuji ZFK7 output)

External O₂ analyzer : 0 to 1 VDC (DC input resistor of 1MΩ or more)

- It is used when the external zirconia O₂ analyzer or external O₂ analyzer is specified as order.
- To connect to the output of the external Zirconia analyzer or external O₂ analyzer prepared separately.
- In case of an external O₂ analyzer, input a signal of 0 to 1 VDC with respect to O₂ full scale of the analyzer.

O₂ sensor input is not isolated. It is recommended to isolate when an external O₂ analyzer is installed apart from this analyzer. Zirconia O₂ sensor Fuji make ZFK7 should be installed at a location that is as close to this instrument as possible.

(4) Contact input (DI): OPTION 1 (1) to (4), (9) to (10), (11) to (14), AUTO CAL (15) to (16)

- It is for a contact input at no voltage. An input is provided when switching to short circuit (on) or open (off).
- No voltage is applied to the terminals.

(5) Contact output (DO): A/O (19) to (20), OPTION 1 (5) to (8), (15) to (20), OPTION 2, AUTO CAL (1) to (14)

- Contact rating: 250VAC/2A, load resistance
- An output is for a relay contact output. An output is provided when switching to conductive (on) or open (off).

Add a ferrite core onto each set of terminals as follows:

one for A/O (19) (20), OPTION (5) to (8) and (15) to (20), one for OPTION 2 terminal, one for AUTO CAL terminal.

Wiring of analog output signal, O₂ sensor input and contact input should be fixed separately from the wiring of power supply and contact output.

Note) To avoid the effect of noise generated from external units, be sure to ground the analyzer main unit. Continue between the I/O module mounting plate and the panel and connect the panel casing to the same ground as the analyzer.

(6) External connection diagram

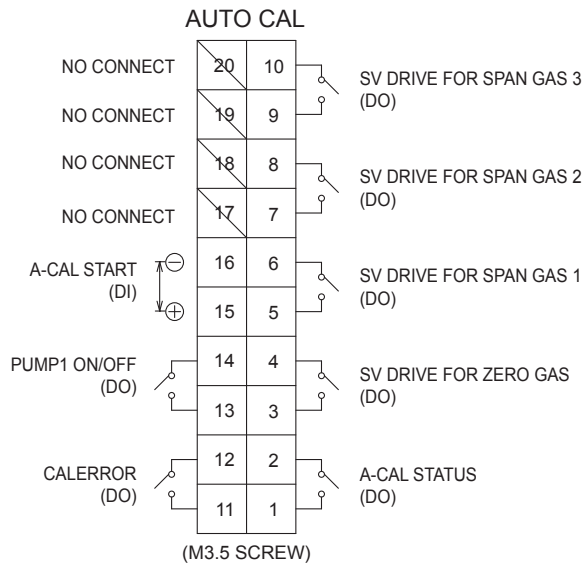
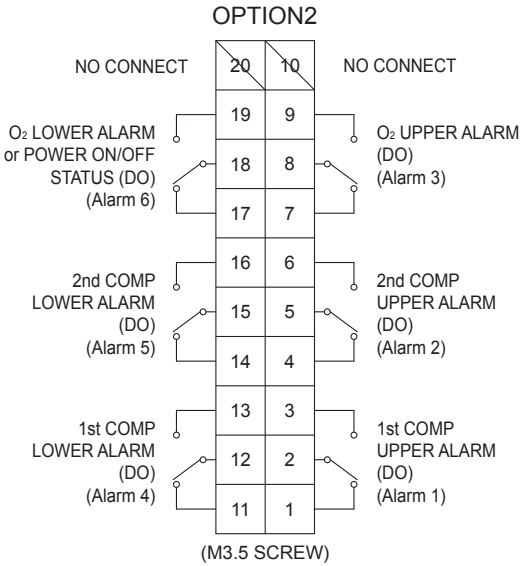
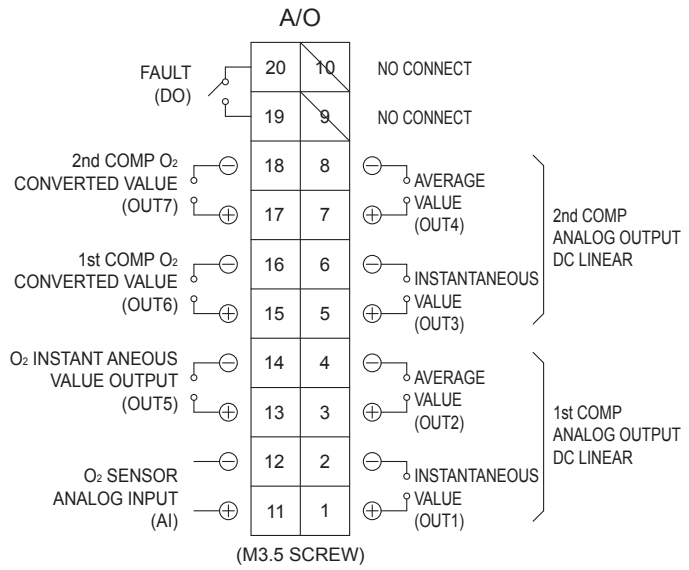
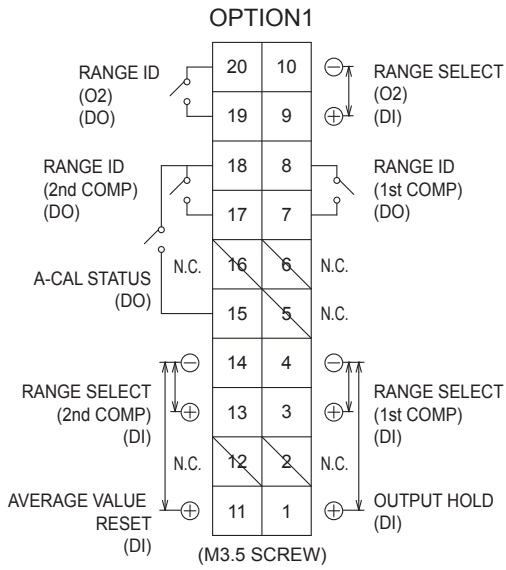

*1) Do not wire for N.C. part terminal. Because it's internally wired.
 *2) A-Cal status output from 2 different terminals simultaneously.

Connector <CN2>
 For serial communication (D-Sub9pin)

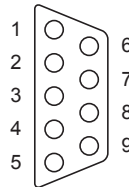

For details, refer to another manual about communication function.

(7) Description on terminal block

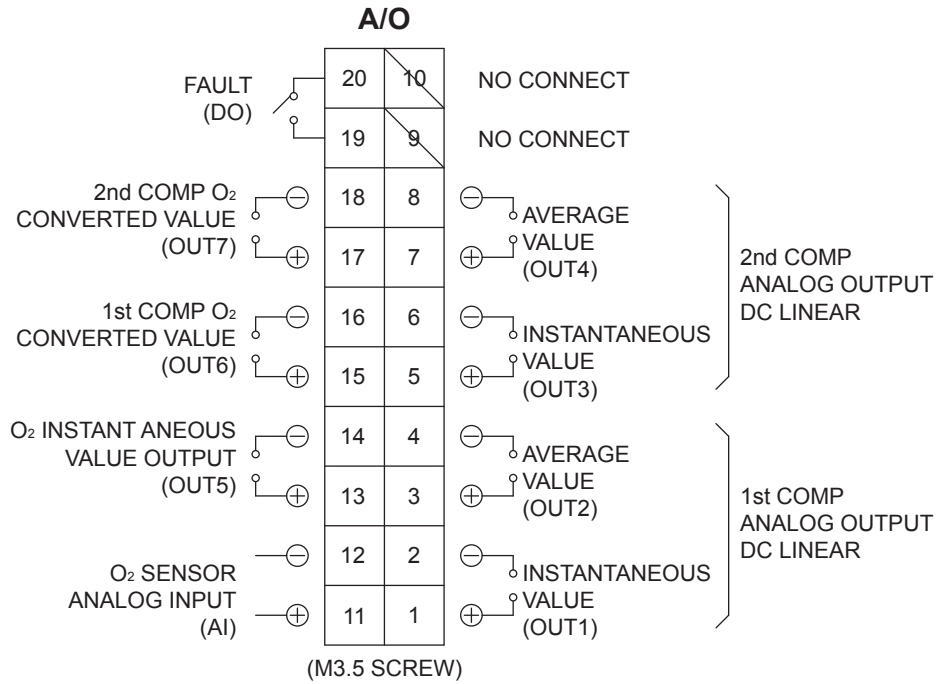

Terminal block <A/O>

- Between 1–2 : 1st component Instantaneous value output
- Between 3–4 : 1st component O₂ converted average value output
- Between 5–6 : 2nd component Instantaneous value output
- Between 7–8 : 2nd component O₂ converted average value output
- Between 9–10 : Must not be used as junction terminal
- Between 11–12 : External O₂ sensor input
 (For input of Fuji's zirconia O₂ sensor or external O₂ sensor.)
 (Must not be used unless external O₂ sensor is provided.)
- Between 13–14 : O₂ Instantaneous value output
- Between 15–16 : 1st component O₂ converted value output
 (2nd component O₂ converted value output)
- Between 17–18 : 2nd component O₂ converted value output
 (O₂ instantaneous value output (0-1V DC))
- Between 19–20 : FAULT output

OPTION 1

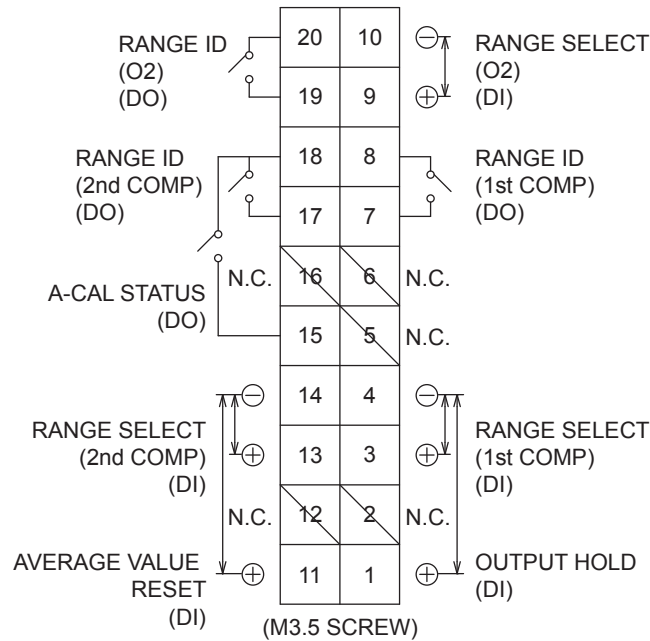

Terminal block <OPTION1>

Between 1–4 : Remote output hold input.

No hold when open. Output is hold when short-circuiting. Please refer to Section 6.7 “parameter setting, Output hold”.

Between 3–4 : 1st component remote range input. Action of remote range switch. (*1)

Between 11–14 : Average value reset input.

As short-circuiting the contact input (for 1.5 sec or more), O₂ average and O₂ converted average are resetted simultaneously. And then average value will be restarted by Opening it. Refer to the Section 6.7 “parameter setting, Reset Av. Output” for details.

Between 15–18 : Auto calibration status contact output.

It is conductive during auto calibration. Otherwise it will be open.

Between 7–8 : 1st component range identification contact output. (*2)

Between 9–10 : O₂ remote range input.

Between 13–14 : 2nd component remote range input. (*1)

Between 17–18 : 2nd component range identification contact output. (*2)

Between 19–20 : O₂ range identification contact output. (*2)

*1. High range is selected when open. Low range is selected when short-circuiting.

*2. It is conductive when 1st range (Low range) is selected. Open when 2nd range (High range) is selected.

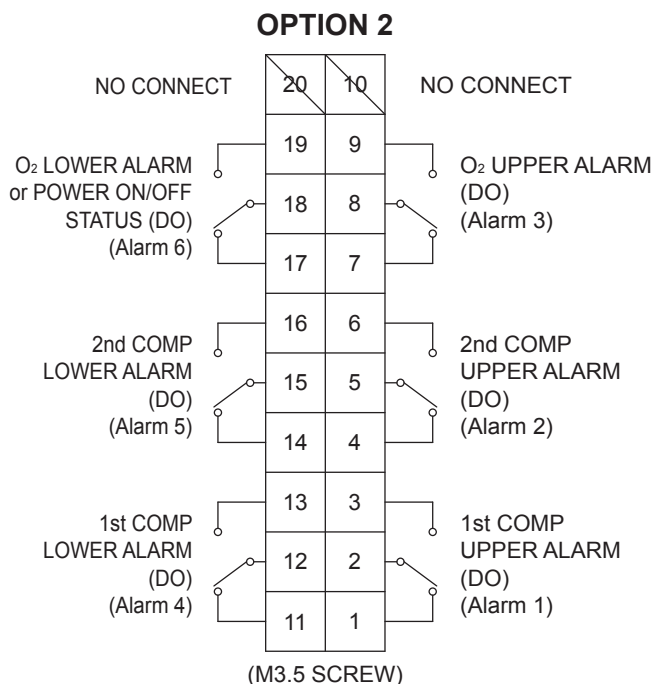

Terminal block <OPTION2>

- Between 1, 2 and 3 : 1st component upper limit alarm contact output.
When the output exceeds the set value, it is conductive between 3 and 2, and open between 2 and 1. Otherwise, it is open between 3 and 2 and conductive between 2 and 1.
 - Between 4, 5 and 6 : 2nd component upper limit alarm contact output.
When the output exceeds the set value, it is conductive between 6 and 5, and open between 5 and 4. Otherwise, it is open between 5 and 6 and conductive between 5 and 4.
 - Between 7, 8 and 9 : O₂ upper limit alarm contact output.
When the output exceeds the set value, it is conductive between 9 and 8 and open between 8 and 7. Otherwise, it is open between 9 and 8 and conductive between 8 and 7.
 - Between 11, 12 and 13 : 1st component lower limit alarm contact output.
When the output exceeds the set value, it is conductive between 13 and 12 and open between 12 and 11. Otherwise, it is open between 12 and 13 and conductive between 12 and 11.
 - Between 14, 15 and 16 : 2nd component lower limit alarm contact output.
When the output exceeds the set value, it is conductive between 16 and 15 and open between 15 and 14. Otherwise, it is open between 16 and 15 and conductive between 15 and 14.
 - Between 17, 18 and 19 : O₂ lower limit alarm contact output.
When the output exceeds the set value, it is conductive between 19 and 18 and open between 18 and 17. Otherwise, it is open between 19 and 18 and conductive between 18 and 17.
- Power ON/OFF status
- When the analyzer unit is energized, it is conductive between 19 and 18 and open between 18 and 17. The analyzer unit is de-energized, it is open between 19 and 18 and conductive between 18 and 17.
- Please refer to the Section 6.3 “alarm setting” for details regarding action of alarm contact.

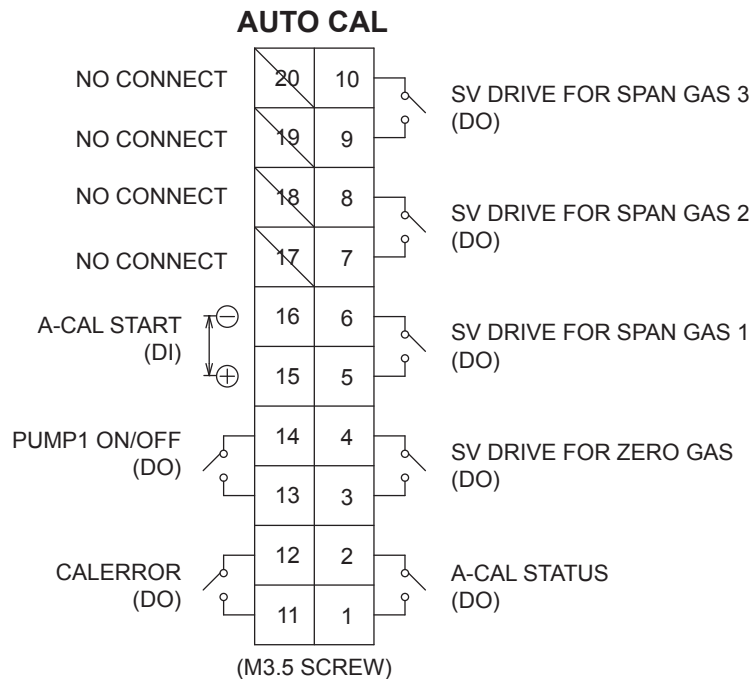

Terminal block <AUTO CAL>

- Between 1–2 : Auto calibration status contact output.
It is conductive during auto calibration. Otherwise it will be open.
- Between 3–4 : Contact output for flowing zero gas.
- Between 5–6 : Contact output for flowing span gas 1.
- Between 7–8 : Contact output for flowing span gas 2.
- Between 9–10 : Contact output for flowing span gas 3.
- Between 11–12 : Calibration error contact output.
It is conductive when error occurs during zero calibration or span calibration. It is normally open.
- Between 13–14 : Pump ON/OFF contact output.
Used when turning ON/OFF the pump. It is open during auto and manual calibration status and conductive during measurement.
- Between 15–16 : Auto calibration remote start input.
After short-circuiting for 1.5 seconds or more, auto calibration is started by the opening input whether the auto calibration setting is ON/OFF. Please refer to the Section 6.4 “Setting of auto calibration” for details.
- Between 17–18 : For internal connection. Must not be wired.
- Between 19–20 : Must not be used as functional terminal.

3.6 Timing of contact output for calibration

1) Manual calibration (See “Section 6.8 Calibration”.)

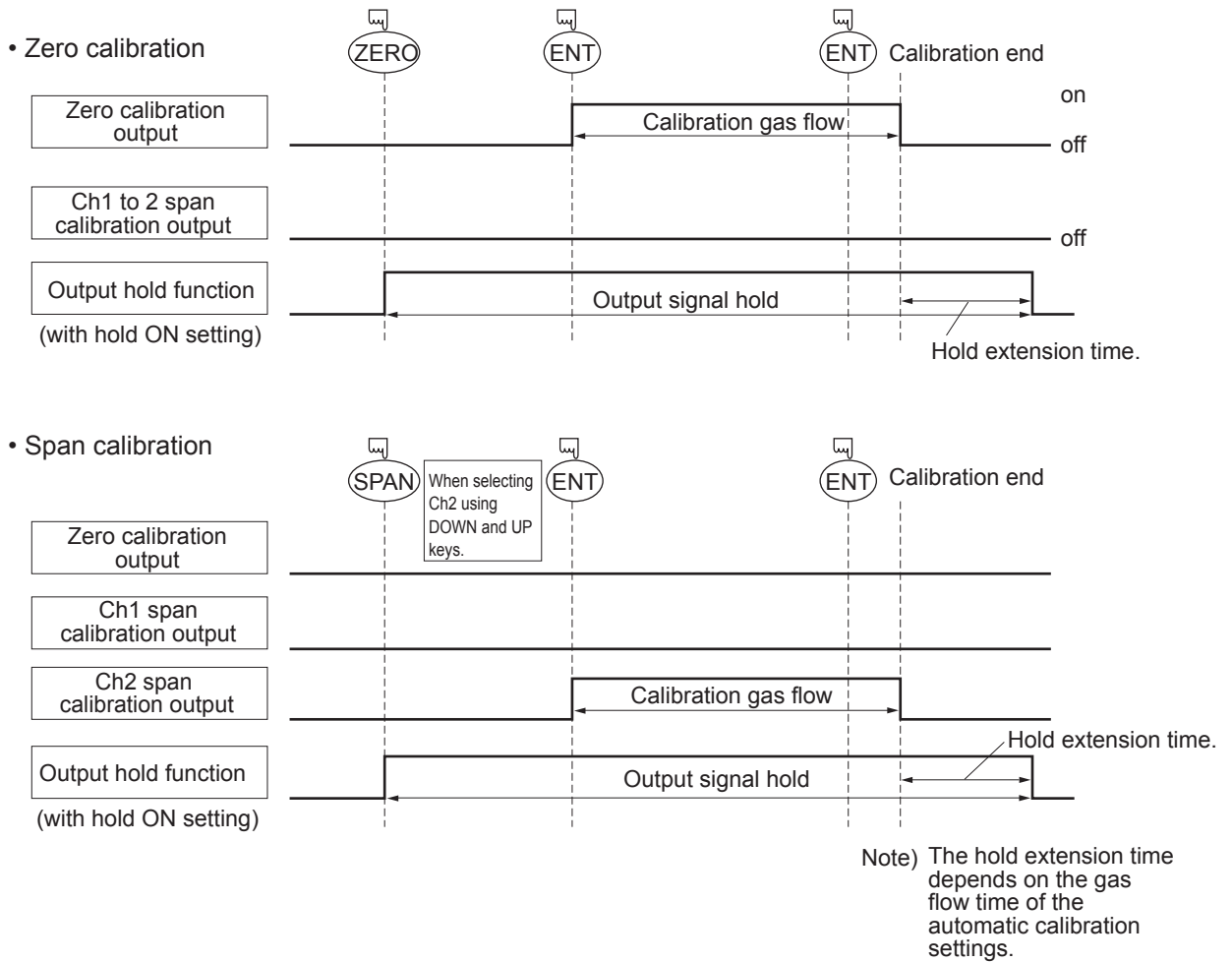

2) In case of automatic calibration (example shown in Section 6.4.1, Auto calibration)

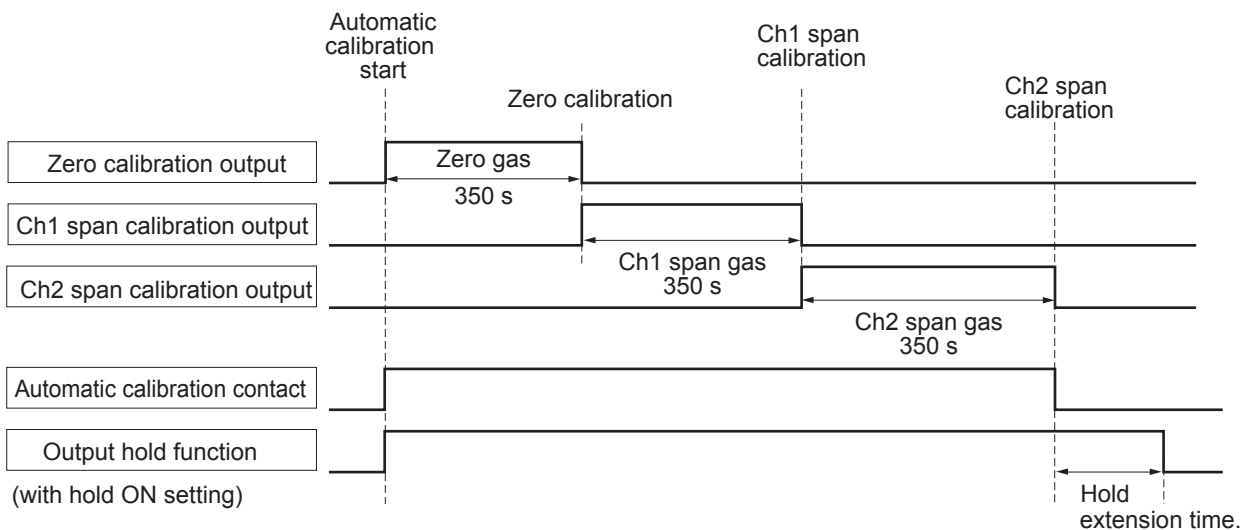

4. OPERATION

4.1 Preparation for operation

(1) Piping and wiring check

Double-check if piping of the gas sampling and exhaust ports are correctly connected.

Double-check for proper wiring.

4.2 Warm-up operation and regular operation

(1) Operation procedure

- 1) Turn ON the power switch on the left side when facing the front panel of the analyzer unit.
The measurement screen appears on the front display panel in 1 to 2 seconds.
- 2) Wait for about 2 hours (for Horizontal type) or 8 hours (for Vertical type) until the instrument is warmed up.
About above hours are required until the instrument allows accurate measurement.

Note) When in warm-up, the concentration reading may be beyond the upper limit of range.

But, it is not an error.

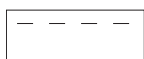

- 3) Setting of various set values
Perform the various settings according to Section 6 “Setting and Calibration”.
- 4) Zero calibration and span calibration
Perform zero/span calibration after warm-up operation.
Refer to Section 6.8 “Manual calibration procedure”.
- 5) Introduction and measurement of sample gas
Introduce the sample gas into the analyzer unit before starting measurement.

5. DESCRIPTION OF DISPLAY AND OPERATION PANELS

This section describes the display unit and operation panel of the analyzer unit. It also explains the name and description of function on the operation panel.

5.1 Name and description of operation panel

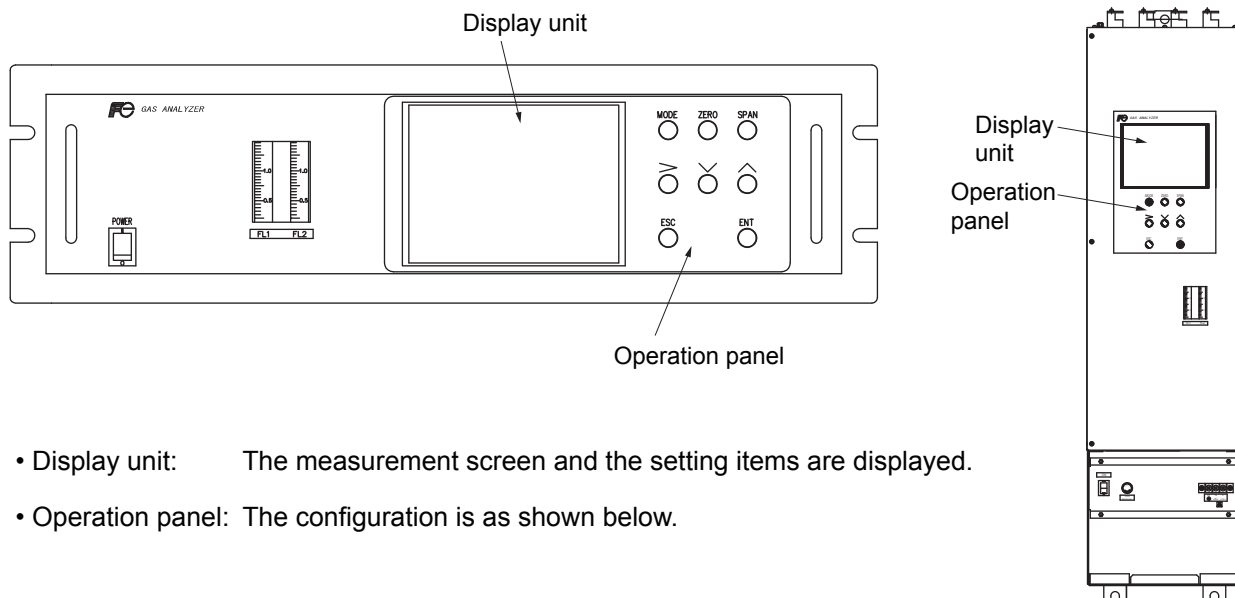

- Display unit: The measurement screen and the setting items are displayed.
- Operation panel: The configuration is as shown below.

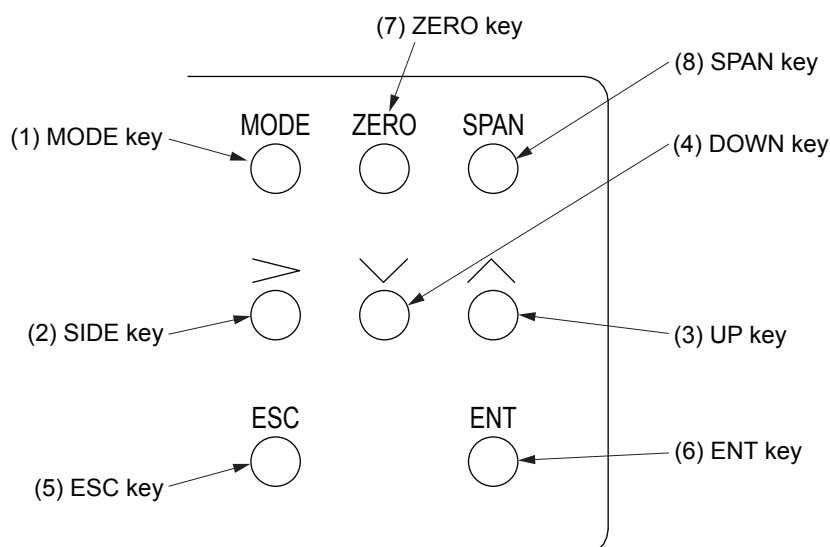

Name	Description	Name	Description
(1) MODE key	Used to switch the mode.	(5) ESC key	Used to return to the previous screen or cancel the setting midway.
(2) SIDE key	Used to change the selected item (by moving the cursor) and the numeral digit.	(6) ENT key	Used for confirmation of selected items or values, and for execution of calibration.
(3) UP key	Used to change the selected item (by moving the cursor) and to increase the numeral value.	(7) ZERO key	Used for manual zero calibration.
(4) DOWN key	Used to change the selected item (by moving the cursor) and to decrease the numeral value.	(8) SPAN key	Used for manual span calibration.

5.2 Overview of display and operation panels

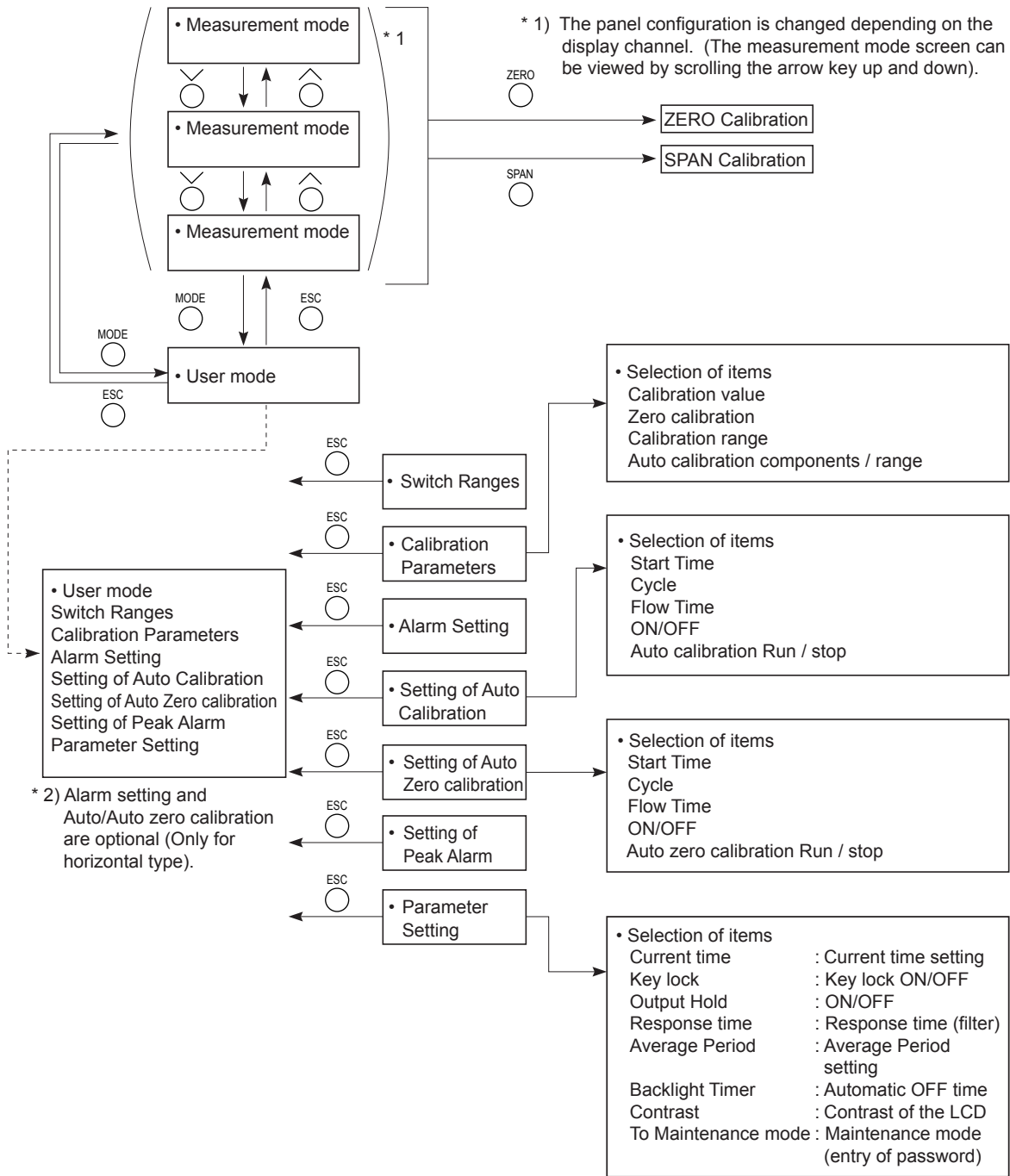

5.3 Outline of display screen

(1) Measurement mode screen (appears when the power is turned ON)

The measurement screen depends on the number of components. The following screen configuration is shown as an example for NO and O₂ (output: 4 channels).

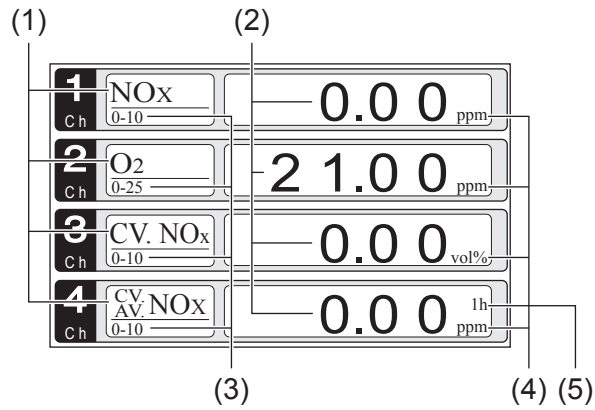

No.	Name	Function
(1)	Component display	Displays the component of instantaneous value, corrected instantaneous value, corrected average value, etc.
(2)	Concentration display	Displays the measured value of concentration.
(3)	Range display	Displays the range values.
(4)	Unit display	Displays the unit with ppm or mg/m ³ and vol%.
(5)	Average time display	Displays the average time.

- **Instantaneous value and concentration value:**

The concentration display of Ch (component) where sampling components such as “NO” and “O₂” are displayed in the component display, indicates current concentration values of the measured components contained in gas that is now under measurement.

- **O₂ corrected concentration values:**

Ch components in which “cv**” is displayed as “cv NO” in the component display are calculated from the following equation. Refer to Section 6.7 “Maintenance mode - Other parameter”.

$$C = \frac{21 - O_n}{21 - O_s} \times C_s$$

O_n: The value of the O₂ correction reference value (Value set by application)

O_s: Oxygen concentration (vol %)

C_s: Concentration of relevant measured component.

Note that O_s does not exceed the O₂ limit value set in Section 6.7 “Maintenance mode - Other parameter”

C: Sample gas concentration (O₂ corrected)

The corrected sampling components are NO_x, SO₂ and CO only.

- **O₂ corrected concentration average value:**

In the Ch (component) and O₂ average value where “^{CV}_{AV} **” is displayed as “^{CV}_{AV} NO” in the component display, a value obtained by averaging O₂ corrected concentration value or O₂ average value in a fixed time is output every 30 seconds.

Averaging time can be changed between 1 to 59 minutes or 1 to 4 hours according to the average time settings (See Section 6.6, Parameter setting).

(The averaging set time is displayed as “1h”, for instance, in the range display.)

* The measurement ranges of O₂ corrected concentration value and O₂ corrected concentration average value are the same as that of the measuring components. Also, the measurement range of O₂ average value is the same as that of O₂.

(2) Setting/selection screen

The setting/selection screen is configured as shown below:

- In the status display area, the current display item is displayed.
- In the message display area, messages associated with operation are displayed.
- In the setting item and selection item display area, items or values to be set are displayed, as required. To work on the area, move the cursor to any item by using UP, DOWN and SIDE keys.

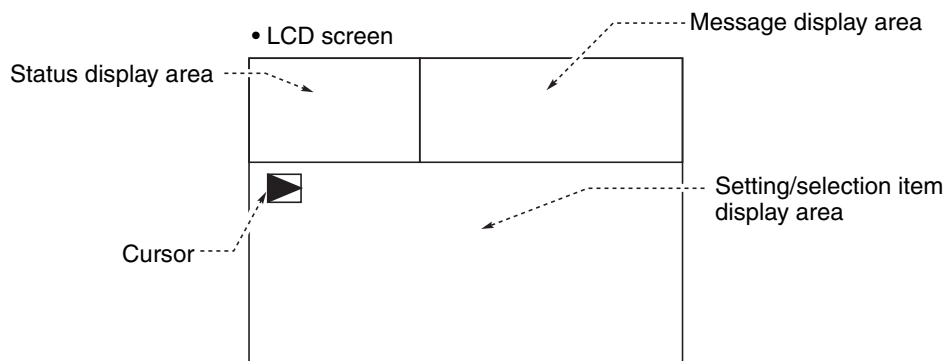

(3) Contents of measured channel (Ch)

The following table gives measurement channels and their contents according to the symbols.

Code Symbol			Display / Output contents
6th digit	7th digit	21th digit	
P	Y	Y	Ch1:NO
A	Y	Y	Ch1:SO ₂
D	Y	Y	Ch1:CO ₂
B	Y	Y	Ch1:CO
P	1 to 4	Y	Ch1:NO, Ch2:O ₂
A	1 to 4	Y	Ch1:SO ₂ , Ch2:O ₂
D	1 to 4	Y	Ch1:CO ₂ , Ch2:O ₂
B	1 to 4	Y	Ch1:CO, Ch2:O ₂
P	1 to 4	A *	Ch1:NO _x , Ch2:O ₂ , Ch3:corrected NO _x
A	1 to 4	A *	Ch1:SO ₂ , Ch2:O ₂ , Ch3:corrected SO ₂
B	1 to 4	A *	Ch1:CO, Ch2:O ₂ , Ch3:corrected CO
P	1 to 4	C *	Ch1:NO _x , Ch2:O ₂ , Ch3:corrected NO _x , Ch4:corrected NO _x average
A	1 to 4	C *	Ch1:SO ₂ , Ch2:O ₂ , Ch3:corrected SO ₂ , Ch4:corrected SO ₂ average
B	1 to 4	C *	Ch1:CO, Ch2:O ₂ , Ch3:corrected CO, Ch4:corrected CO average

* When the 21st digit code is A or C, the component of the NO analyzer is displayed as NO_x.

5.4 Basic operation

• Measurement mode

The measurement mode can display up to 4 channels in a single screen.

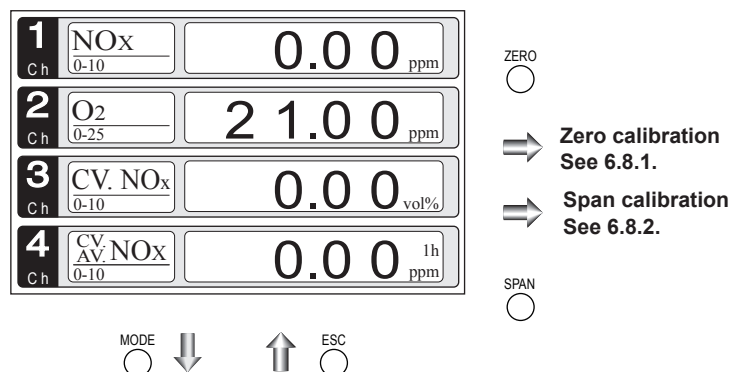

• User mode displays

- Switch Ranges
- Calibration Parameters
- Alarm Setting
- Setting of Auto Calibration
- Setting of Auto Zero Calibration
- Setting of Peak Alarm
- Parameter Setting

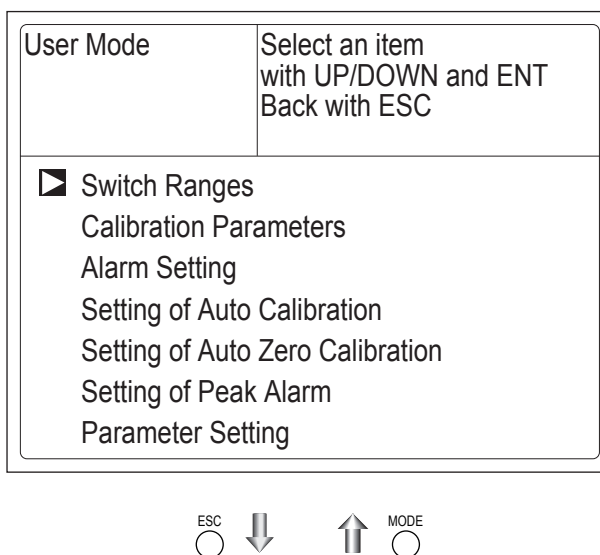

Measurement Mode Screen

Press the or the key and move the cursor preceding the each display item. Each display item is displayed by pressing the key.

For the setting contents, refer to Section 6 “Setting and calibration”.







6. SETTING AND CALIBRATION



The setting procedure and calibration procedure are common between the horizontal type and the vertical type.

6.1 Switch of range

6.1.1 Setting of range switch mode

Set the range switch mode as follows.

- (1) Press the  key in measurement mode to display the User mode screen.
- (2) Move the cursor to “Switch Ranges” and press the  key.
- (3) In the “Channel Selection” screen that appears, move the  cursor by pressing the  or the  key, and select Ch (component).
- (4) Then press the  key.

- (5) Selected range switch mode is highlighted.
Press the  or the  key to select a desired switch mode.

Description of setting

- MR: Select a desired range on this screen.
 RR: Select a desired range according to the remote range switch contact input.
 AR: Automatically switched from Range 1 to Range 2 when the measured concentration exceeds 90% of Range 1. Automatically switched from Range 2 to Range 1 when the measured concentration becomes less than 80% of Range 1.
 * Operation set for each Ch only can be performed.

- (6) Then press the  key to confirm the selection.
If “MR” is selected, the cursor moves to “Range Switch.”

Measurement Mode Screen



User Mode	Select an item with UP/DOWN and ENT Back with ESC
<input checked="" type="checkbox"/> Switch Ranges	
Calibration Parameters	
Alarm Setting	
Setting of Auto Calibration	
Setting of Auto Zero Calibration	
Setting of Peak Alarm	
Parameter Setting	



Switch Ranges	Select Ch No. with UP/DOWN and ENT Back with ESC
<input checked="" type="checkbox"/> Ch1 NO _x	MR
Ch2 O ₂	AR



Switch Ranges	Select method of switch ranges with UP/DOWN and ENT Back with ESC
Ch1 NO _x	<input checked="" type="checkbox"/> MR
Ch2 O ₂	AR



Range switch
or previous screen

6.1.2 Manual range switch

The range of the measured component can be switched manually as follows.

- (1) Select “MR” as range switch mode, and then press the ENT key.

Switch Ranges		Select method of switch ranges with UP/DOWN and ENT Back with ESC		
Ch1 NO _x	MR	▶ Range1	0–10.00	ppm
		Range2	0–100.0	ppm
Ch2 O ₂	AR	▶ Range1	0–10.00	vol%
		Range2	0–25.00	vol%



- (2) Move the highlight of the cursor to range selection, and then select a desired range by pressing the $\hat{\text{O}}$ or the $\check{\text{O}}$ key. (The ▶ mark indicates the currently selected range.)
- (3) Then press the ENT key, and the measurement is carried out in the selected range.

Switch Ranges		Select range with UP/DOWN and ENT Back with ESC		
Ch1 NO _x	MR	▶ Range1	0–10.00	ppm
		Range2	0–100.0	ppm
Ch2 O ₂	AR	▶ Range1	0–10.00	vol%
		Range2	0–25.00	vol%



End of Range Switch

Note) If “RR” or “AR” is selected as range switch mode, this operation cannot be performed.

The ranges for O₂ correction value, O₂ correction average value, and O₂ average value are automatically switched according to the instantaneous value range switch settings. (Same as for “RR” or “AR”).

To close the setting

Press the ESC key to end the setting of range switch mode or range switch operation or stop the operation in the middle. The setting operation is made invalid and the previous screen appears.

Range identification contact operation

The range identification contact output corresponding to each Ch (component) is closed when Range 1 is active, and open when Range 2 is active, no matter. If the measurement value is held by remote contact input or during calibration routine and range switch conditions are met, the contact will change position only after the hold condition is removed.

6.2 Calibration setting

This mode is used to set calibration concentration and actions. The calibration setting involves calibration concentration, zero calibration, calibration range and auto calibration component/range.

Select the “Calibration Parameters”, the screen appears as shown at right.

Cal. Parameters	Select an item with UP/DOWN and ENT Back with ESC
<input checked="" type="checkbox"/> Calibration Value About ZERO Calibration About Calibration Range Auto Calibration Components / Range	



6.2.1 Setting of calibration concentration

It allows you to set concentrations of the standard gas (zero and span) of each Ch used for calibration.

- (1) Select < User mode > → < Calibration parameters > → < Calibration value >. “Calibration Value Settings” screen appears as shown at right.
- (2) Select the Ch you want to change by pressing the or the key. Press the key and cursor moves preceding the value.
- (3) Select the concentration item you want to set by pressing the , key or the key (movable within the selected Ch). Then press the key, and the selected value is highlighted.

Cal. Settings		Select setting value	
Cal. Value			
Ch	RANGE	ZERO	SPAN
Ch1	0-10.00ppm	+0000.0	10.00
NOx	0-100.0ppm	+00000	100.0
Ch2	0-10.00vol%	21.00	1.00
O ₂	0-25.00vol%	21.00	1.00



(4) Then, enter calibration gas concentration values (zero and span). For value entry, press the $\hat{\circ}$ or the $\check{\circ}$ key, and a 1-digit value increases or decreases. By pressing the $\check{\circ}$ key, the digit moves. After setting, save the entry by pressing the $\overset{\text{ENT}}{\circ}$ key. The saved value becomes valid from the next calibration process.

Note) Enter settings that correspond to each range. If zirconia type is used as O₂ sensor, select 21.00 for the field of Zero (when ambient air is used), and select the concentration listed on the cylinder as required.

\downarrow $\check{\circ}$ ($\hat{\circ}$) $\overset{\text{ENT}}{\circ}$

Cursor for setting value

Cal. Settings Cal. Value		Set calibration value	
Ch	RANGE	ZERO	SPAN
Ch1	0-10.00ppm	+0000.0	10.00
NO _x	0-100.0ppm	+00000	100.0
Ch2	0-10.00vol%	21.00	01.00
O ₂	0-25.00vol%	21.00	01.00

\downarrow $\check{\circ}$ $\hat{\circ}$ $\overset{\text{ENT}}{\circ}$

**End of Calibration
Concentration Setting**

To close the setting

To close the calibration concentration value setting process or cancel this mode midway, press the $\overset{\text{ESC}}{\circ}$ key. A previous screen will return.







Setting range of values

<p>NO_x, SO₂, CO₂, CO, external O₂ measurement and built-in O₂ sensor</p>	<p>Span gas: 1 to 105% of full scale (Full scale (FS) is the same as each range value.)</p>
<p>External Zirconia O₂ measurement</p>	<p>Zero gas: 5 to 25 vol% Span gas: 0.01 to 5 vol%</p>

The setting cannot be performed beyond the range.

6.2.2 Setting of manual zero calibration

When zero calibration is made manually, set if all measurement components should be calibrated simultaneously or one by one.

- (1) Select < User mode > → < Calibration parameters > → < Zero calibration >. “Zero Calibration” screen appears as shown at right.
- (2) Select the Ch you want to change by pressing the  or the  key. Press the  key and the setting content is highlighted.
- (3) Select “at once” or “each” by pressing the  or  key.
 - When selecting “at once”, the Ch (components) to be set can be zero-calibrated at the same time.
 - When selecting “each”, the individual Ch (component) as shown at right is selected and zero-calibrated.
 Press the  key after the setting, and the specified calibration is performed.

Cal. Settings ZERO Cal.		Set each or at once Ch at ZERO Calibration	
Ch1 NOx	Range1 Range2	0-10.00 ppm 0-100.0 ppm	at once
Ch2 O ₂	Range1 Range2	0-10.00 vol% 0-25.00 vol%	each



**End of
Manual Zero Calibration Setting**

To close the setting

To close the manual zero calibration setting or to cancel this mode midway, press the  key. A previous screen will return.

Description of setting

Whether “each” or “at once” can be determined for each Ch (component).

- Setting “each”
Select the Ch (component) on the manual zero calibration screen and then perform the zero calibration.
- Setting “at once”
At a manual zero calibration, Ch (components) for which “at once” was selected can simultaneously be zero-calibrated.

Manual Calibration screen

•When setting all components to “each”:

ZERO Cal.		ENT : Go on calibration of selected Ch ESC : Not calibration	
Ch1 NOx	▶ Range1 Range2	0-10.00 ppm 0-100.0 ppm	▣ -2.1
Ch2 O ₂	▶ Range1 Range2	0-10.00 vol% 0-25.00 vol%	21.00

A single cursor will appear.

•When setting all components to “at once”:

ZERO Cal.		ENT : Go on calibration of selected Ch ESC : Not calibration	
Ch1 NOx	▶ Range1 Range2	0-10.00 ppm 0-100.0 ppm	▣ 0.0
Ch2 O ₂	▶ Range1 Range2	0-10.00 vol% 0-25.00 vol%	▣ 21.00

Cursors will appear at all components
where “at once” is set.

6.2.3 Setting of calibration range

This mode is used to set if the range of each Ch (component) at the zero or span calibration (manual or auto calibration) should be calibrated with a single range or 2 ranges.

- (1) Select < User mode > → < Calibration parameters > → < Calibration range >. “Calibration Range” screen appears as shown at right.
 - (2) Select the Ch you want to change by pressing the $\hat{\circ}$ or the $\check{\circ}$ key. Press the ENT \circ key and the setting contents is highlighted.
 - (3) Select “both” or “current” by pressing the $\hat{\circ}$ or the $\check{\circ}$ key.
 - If “both” is selected, zero or span calibration is performed with Range 1 and Range 2 of the selected Ch interlocked when calibration is performed.
 - If “current” is selected, zero or span calibration is performed only for the range displayed when calibration is performed.
- Press the ENT \circ key after the selection, and the specified calibration is performed.

Cal. Settings		Set calibration range	
Cal. Range		current or both range	
Ch1	Range1	0-10.00 ppm	both
NOx	Range2	0-100.0 ppm	
Ch2	Range1	0-10.00 vol%	current
O2	Range2	0-25.00 vol%	



End of Calibration Range Setting

To close “Setting of Calibration Range”

To close “Setting of Calibration Range” or to cancel this mode midway, press the ESC \circ key. A previous screen will return.

Example

Ch1	Range 1: 0 to 10 ppm	both
NOx	Range 2: 0 to 100 ppm	
Ch2	Range 1: 0 to 10 vol%	current
O2	Range 2: 0 to 25 vol%	

Ch1: Range 1 and Range 2 are calibrated together.

Ch2: Only currently displayed range is calibrated.

Note

To perform calibration for “both,” set the same calibration gas concentration for both ranges.

Manual Calibration screen







When setting NOx to “both”

ZERO Cal.		ENT : Go on calibration of selected Ch	
		ESC : Not calibration	
Ch1	▶ Range1	0-10.00 ppm	-0.6
NOx	Range2	0-100.0 ppm	
Ch2	▶ Range1	0-10.00 vol%	
O2	▶ Range2	0-25.00 vol%	21.00

Two cursors will appear in both ranges (Ch1).

6.2.4 Setting of auto calibration component/range

Select the Ch (component) and the range for which auto calibration is to be performed. The Ch for which “AR” has been selected as range switch mode is calibrated in the range set here. Auto calibration and the manual calibration of the component for which “AR” has been selected as range switch mode are performed in the range selected here.





- (1) Select < User mode > → < Calibration parameters > → < Auto calibration component/range >. “Auto Calibration Component Range” setting screen appears as shown at right.
- (2) Select the Ch you want to change by pressing the  or the  key. Press the  key and the selected cursor is highlighted.
- (3) Select the range to be calibrated mainly by pressing the  or the  key.
- (4) Then press the  key, and calibration is performed in the selected range when auto calibration or auto zero calibration is performed.



“Auto Calibration Component/range” setting

Auto calibration and the manual calibration of the component for which “AR” has been selected as range switch mode are performed in the range selected here. In this case, once the calibration is started, the range is automatically switched, and on completion of the calibration, the original range is resumed.

The range identification contact is interlocked with the range after the switch.

However, if the hold setting is set to “ON,” the contact status before calibration is maintained.

- (5) Press the  key in the state described in (3), and the highlight is switched between “enable” and “disable” auto calibration.
- (6) Select “enable” or “disable” by pressing the  or the  key.
- (7) Then press the  key.

Cal. Settings Auto Cal.		Select a range for auto calibration	
Ch1	 Range1	0–10.00 ppm	enable
NOx	Range2	0–100.0 ppm	
Ch2	Range1	0–10.00 vol%	enable
O2	 Range2	0–25.00 vol%	

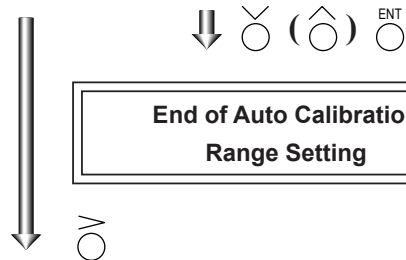

Cal. Settings Auto Cal.		Set enable or disable for auto calibration	
 Ch1	Range1	0–10.00 ppm	enable
NOx	Range2	0–100.0 ppm	
Ch2	Range1	0–10.00 vol%	enable
O2	Range2	0–25.00 vol%	

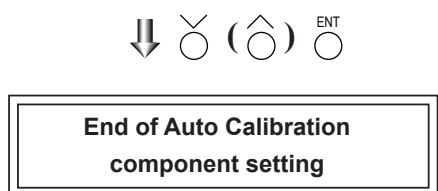

To close the setting

Press the  key to exit automatic calibration component/range setting, and the previous screen appears.

Operation by setting

Auto calibration is performed under the following rules.

1. Zero calibration is performed at the same time, for the Ch (component) in which “enable” is selected at the time of auto calibration and auto zero calibration.
2. Span calibration is performed in the order from smallest Ch No., for the Ch (component) for which “enable” is selected at the time of auto calibration.

Note

ZERO calibration on auto calibration and auto zero calibration of the component for which “enable” is selected are performed in batch irrespective of the description in Section 6.2.2 “Setting of manual zero calibration.”

6.3 Alarm setting

6.3.1 Setting of alarm values

The High/Low limit alarm output setting for the measured concentration can be made. 5 (for horizontal type) or 6 (for vertical type) different alarm contact outputs can be used.

In case of vertical type, at the time of shipment, the alarm is set up in advance that is described in Section 3.5 (7) option 2.

To change alarm setting, set the alarm ON/OFF setting to OFF, and then change the value.

- Enter the "Setting of Alarm No." screen from the user mode, and the display shown at right appears. Point the cursor to the Alarm No. or hysteresis you want to set by pressing $\hat{\circ}$ or the $\check{\circ}$ key. Press the ENT key.

Alarm Setting	Select Alarm No. or Hysteresis setting
<input checked="" type="checkbox"/> Alarm-1 <input type="checkbox"/> Alarm-2 <input type="checkbox"/> Alarm-3 <input type="checkbox"/> Alarm-4 <input type="checkbox"/> Alarm-5 <input type="checkbox"/> Alarm-6	
Hysteresis	00 %FS



- Select the alarm 1 to display the screen shown at right. Operate the $\hat{\circ}$ or the $\check{\circ}$ key until the cursor is aligned with a desired item and press the ENT key.

Alarm Setting Alarm-1	Select an item with UP/DOWN and ENT Back with ESC
<input checked="" type="checkbox"/> Channel <input type="checkbox"/> H-Limit Range 1 <input type="checkbox"/> Range 2 <input type="checkbox"/> L-Limit Range 1 <input type="checkbox"/> Range 2 <input type="checkbox"/> Kind of Alarm <input type="checkbox"/> ON / OFF	Ch1 10.00 ppm 100.0 ppm 000.0 ppm 0000 ppm High OFF



Cursor for setting value

Alarm Setting Alarm-1	Set value
Channel H-Limit Range 1 Range 2 L-Limit Range 1 Range 2 Kind of Alarm ON / OFF	Ch1 10.00 ppm 100.0 ppm 000.0 ppm 0000 ppm High OFF



End of Alarm Setting

Note

Set the values so that H-limit value > L-limit value and that (H-limit value - L-limit value) > hysteresis.

When "0" is set, the alarm operation is not performed.

- After setting, the alarm setting is now completed by pressing the ENT key.

To close the "Alarm Setting"

To close the "Alarm Setting" or to cancel this mode midway, press the ESC key. A previous screen will return.

Setting range

0% to 100% FS (Settable in each range).

Description of setting items

The alarm contact assigned the same number as the alarm is operated accordingly.

Channel: Channel setting targeted for issuance of alarm.
One Ch No. can be selected for multiple alarms.
Power ON/OFF status (DO) can be set to alarm-6.

H-Limit value: Set the high limit value (concentration) of alarm.

L-Limit value: Set the low limit value (concentration) of alarm.

Kind of Alarm: Select one of High limit alarm, Low limit alarm, and High limit or Low limit alarm, HH limit alarm, and LL limit alarm.
High, HH Alarm contact closes when above H-limit alarm.
Low, LL Alarm contact closes when below L-limit alarm.
High or Low... Alarm contact closes when above H-limit value or below lower limit value.

ON/OFF: Enables the alarm function if set at ON, or disables it if set at OFF.

* The H-limit value cannot be set below the L-limit value, and the L-limit value cannot be set above the H-limit value.

If it is desired to set the H-limit value below the L-limit value, reduce the L-limit value beforehand, and vice versa.

Typical on-screen display when an alarm occurs

When an H-limit alarm occurs, the “H-alarm” message comes on in the field of relevant Ch (component).
 (“L-alarm” for L-limit alarm, “HH-alarm” for HH limit alarm, and “LL-alarm” for LL limit alarm)

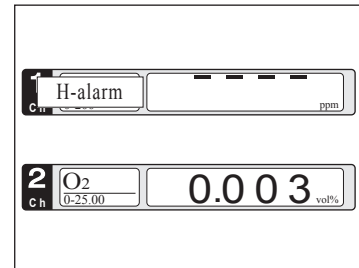

CAUTION

After turning on power, the alarm logic trigger is inactive for 10 minutes.

6.3.2 Hysteresis setting

To prevent chattering of an alarm output near the alarm setting values, adjust the value of hysteresis.

- (1) In the "Alarm Setting" screen that appears, point the cursor to "Hysteresis" by pressing the \uparrow or the \downarrow key. Press the ENT key to display the screen shown at right.
- (2) Then, enter hysteresis values.
For the value entry, 1-digit value is increased or decreased by pressing the \uparrow or the \downarrow key, and pressing the \rightarrow key moves the digit. After setting, press the ENT key to make the "Hysteresis" valid.

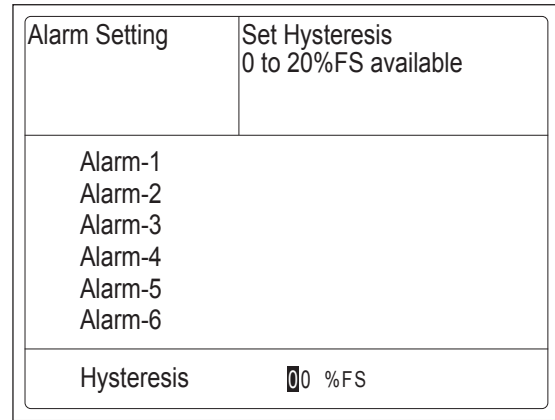

End of Hysteresis Setting

To close "Hysteresis Setting"

To close the "Hysteresis Setting" or cancel the mode midway, press the ESC key. A previous screen will return.

Setting range

0 to 20% of full scale
[% full scale (% FS)] represents the percentage with the width of the component measurement range regarded as 100%.

CAUTION

The hysteresis is common to all alarms (components). Hysteresis in peak alarm setting described in Section 6.3.3 should be set separately.

Hysteresis (In case of upper limit alarm)



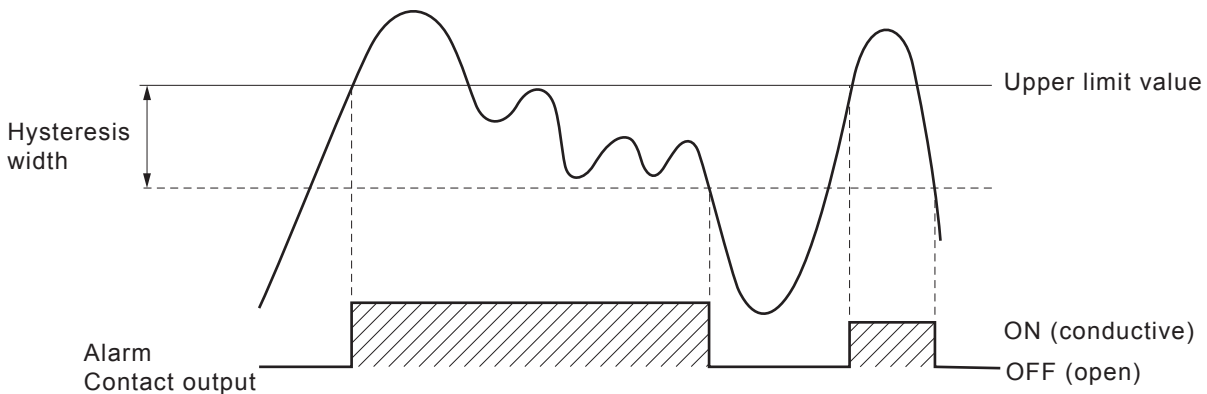



An alarm output is turned ON if measurement value exceeds the upper limit value as shown below. Once the alarm output has been turned ON, it is not turned OFF as long as the indication does not fall below the hysteresis width from the upper limit value.





6.3.3 Peak alarm setting (Only for horizontal type)

When the peak number of times CO concentration exceeds the upper limit value during measurement reaches the set number, an alarm is provided.

The peak alarm and this setting screen appear only when an option is added.

- (1) Press the  key in the Measurement mode, and the User mode appears.
- (2) Point the cursor to “Setting of Peak Alarm” by pressing the  or  key. Press the  key.
- (3) In the “Setting of Peak Alarm” item selection screen that appears, point the cursor to any item you want to set by pressing the  or  key. Press the  key.
- (4) Then, enter numeric values and perform the setting.

Entering the numeric values or setting the items should be carried out by using the  or  key.

After setting, press the  key, and the set values are saved.

Description of setting items

- Peak Alarm : ON/OFF of peak alarm
- Alarm Value : If measuring value exceeds the set alarm value, a peak counter counts 1 time.
- Alarm Count : When the alarm value is exceeded this many times per hour, the peak count alarm is activated (closed).
- Hysteresis : To prevent possible chattering when the measuring value may exceed the set peak concentration by only 1 time, the peak count has an allowance in the hysteresis width.



User Mode	Select an item with UP/DOWN and ENT Back with ESC
Switch Ranges Calibration Parameters Alarm Setting Setting of Auto Calibration Setting of Auto Zero Calibration <input checked="" type="checkbox"/> Setting of Peak Alarm Parameter Setting	



Peak Alarm	Select setting item
<input checked="" type="checkbox"/> Peak Alarm OFF Alarm Value 0500 ppm Alarm Count 05 times Hysteresis 00 %FS	



Peak Alarm	Set Peak Alarm ON or OFF
Peak Alarm OFF Alarm Value 0500 ppm Alarm Count 05 times Hysteresis 00 %FS	





End of Peak Alarm Setting

Setting range

- Alarm value : 10 to 1000 ppm → 5 ppm step (initial value: 500 ppm)
 - Alarm count : 1 to 99 times (per hour) → (initial value: 5 times)
 - Hysteresis : 0 to 20 % of full scale → (initial value: 0% of full scale)
- [% full scale] represents the percentage with the CO measuring range value regarded as 100%.

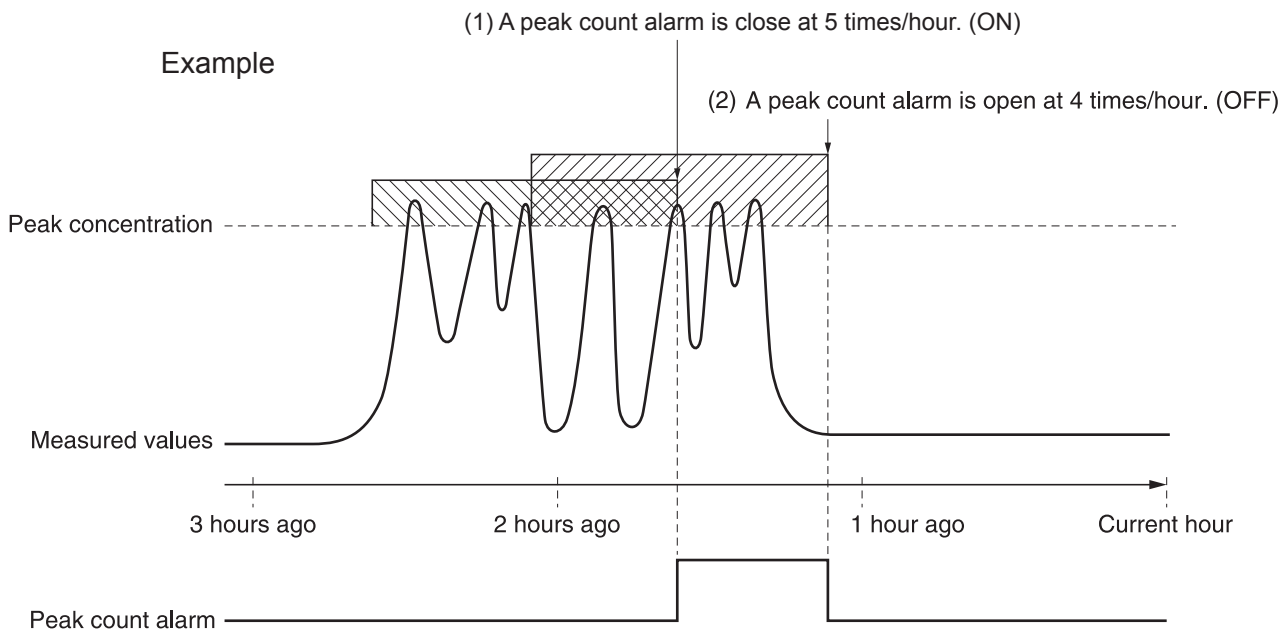
Action of peak alarm



If CO concentration exceeds the alarm value, counting will begin. If the number of peaks is over the set times per hour, a peak alarm contact output becomes closed (ON). If it is less than the set times per hour, it is open (OFF). Since 5 times of peaks /hour is marked at (1)  section from the above graph, the peak count alarm is turned ON. Since peaks of more than 5 times per 1 hour occur at the interval between (1) and (2) , the peak count alarm remains ON. Since at (2), peaks are reduced to 4 times per hour, it is turned OFF.

Like the hysteresis of the alarm setting, the hysteresis prevents possible chattering when measured gas is fluctuated near the alarm value.

* For 10 minutes after the power is turned ON, a peak alarm counting logic is not carried out.

Releasing peak count alarm

To release the peak count alarm, set the peak alarm to OFF.
Turning on the peak alarm initiates counting from 0.

6.4 Setting of auto calibration

6.4.1 Auto calibration

Auto calibration is automatically carried out at the time when zero and span calibration are set. Before changing the setting of auto calibration, set the ON/OFF to OFF.

- (1) Enter the "Setting of Auto Calibration" screen from the user mode, and the display shown at right appears. Operate the $\hat{\circ}$ or the $\check{\circ}$ key until the cursor is aligned with a desired item and press the $\overset{\text{ENT}}{\circ}$ key.

Set Auto Cal.	Select setting item
Start Time	SUN 12:00
Cycle	07 day
Flow Time	
ON / OFF	OFF
Time : MON 12:34	
Auto Calibration Run	



- (2) In the "Setting of Auto Calibration" screen that appears, perform the value entry or the setting. For the value entry or setting change, use the $\hat{\circ}$ or the $\check{\circ}$ key, and the $\check{\circ}$ key to move the cursor to the right.

After setting, press the $\overset{\text{ENT}}{\circ}$ key, and auto calibration is carried out by the entered setting value.

Set Auto Cal.	Set Start Time
Start Time	SUN 12:00
Cycle	07 day
Flow Time	
ON / OFF	OFF
Time : MON 12:34	
Auto Calibration Run	

Press the $\hat{\circ}$ or the $\check{\circ}$ key, and date and time are displayed alternately.



End of Auto Calibration Setting









Description of setting items

- Start Time : Setting at the first calibration (day of the week, hour, minute)
- Cycle : A period between the start time of one calibration and the next (unit : hour/day)
- Flow Time : The time required for replacement by calibration gas
Time required for replacement of sample gas after the calibration is completed (Set by calibration gas. See the next page.)
- ON/OFF : ON/OFF of auto calibration

To close "Setting of Auto calibration"

To close the "Setting of Auto calibration" or cancel this mode midway, press the $\overset{\text{ESC}}{\circ}$ key. A previous screen will return.

<Gas flow time> setting

- (1) Press the  key in a state where the cursor is placed preceding "Flow Time," and the flow time setting screen appears.
- (2) Move the cursor to the gas you want to change by pressing the  or the  key, and then press the  key.
- (3) The highlighted value can be changed. Change the value by pressing the  or the  key, and then move the cursor to the right by pressing the  key.
- (4) After changing the value, press the  key.
- (5) Press the  key to return to the automatic calibration setting screen.

Set Auto Cal.	Set flow time of calibration gas 60 to 900 sec
ZERO	 50 sec.
Ch1 Span	350 sec.
Ch2 Span	350 sec.
Ex. time	300 sec.



End of Gas flow time Setting

Note) Only the Chs used are displayed on this screen. The Ex. time is the output signal hold extension time after the completion of calibration. It is valid only when the hold setting is set to "ON." The Ex. time set here is also the hold extension time at the time of manual calibration.

Auto calibration status contact output is closed during auto calibration (NO side), and is open in other cases.

Example

Start Time	SUN	12:00
Cycle	1	day
Flow Time	Zero	350 sec
	Ch1 Span	350 sec
	Ch2 Span	350 sec
	EX. time	300 sec
ON/OFF	ON	

In case where auto calibration is carried out at the above setting.

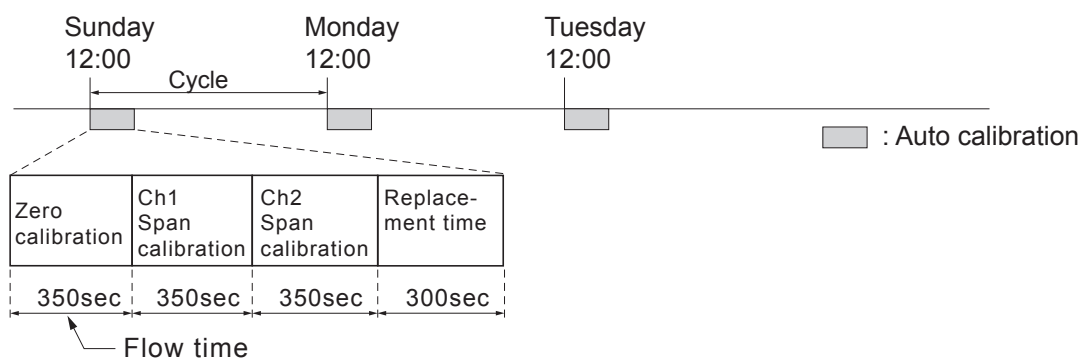

(An example of “Ch1 and Ch2: enable”, as given in Section 6.2.4 “Auto Calibration Components/range”)

Setting range

Cycle : 1 to 99 hours or 1 to 40 days (initial value 7 days)
 Flow time : 60 to 900 sec (initial value 300 sec)

⚠ CAUTION

- When an auto calibration starts, the measurement screen appears automatically.
- During auto calibration, any key operation is not permitted other than operations such as key lock ON/OFF and “Forced stop of auto calibration” (see Section 6.4.2.2). When the key lock is set at ON, even the “Forced stop of auto calibration” cannot be performed. To cancel auto calibration forcibly, set the key lock to OFF and then execute “Forced stop of auto calibration”.
- Turn on the power again after it is turned off (including the case of power failure) at the time set as the next start time in auto calibration, and then repeat it in the set cycle.
- When the hold setting is set to ON, the hold time of auto calibration contact and measurement value output signal are extended after calibration for gas replacement time.

Remote start



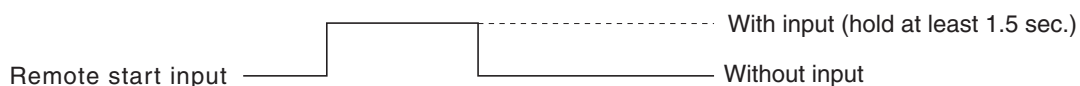

Whether the auto calibration is set at ON or OFF, an auto calibration is available by remote start input.



6.4.2 Forced run/stop of auto calibration

Auto calibration can be performed just once or forcibly stopped while the calibration is performed.





6.4.2.1 Execution of auto calibration (only once)

- (1) In the “Setting of Auto Calibration” screen that appears, point the cursor to “Auto Calibration Run” by pressing the  or the  key. Press the  key.
- (2) “Run” is highlighted, displaying a message to confirm the execution of auto calibration. Press the  key to execute the auto calibration, or press the  key to cancel.

Set Auto Cal.	Auto Cal. Run ENT : Run / Stop ESC : Cancel
Start Time	SUN 12:00
Cycle	07 day
Flow Time	
ON / OFF	OFF
	Time : MON 12:34
Auto Calibration Run	

6.4.2.2 Forced stop of auto calibration

This mode is used to stop the auto calibration forcibly.

- (1) In the “Setting of Auto Calibration” screen that appears, point the cursor to “Auto Calibration Stop” by pressing the  or the  key. Press the  key. (“Auto Calibration Stop” appears when the screen is selected while auto calibration is performed.)
- (2) “Stop” is highlighted, displaying a message to confirm the stop of auto calibration. Press the  key to stop the auto calibration, or press the  key to cancel (not stopped).

Set Auto Cal.	Auto Cal. Stop ENT : Run / Stop ESC : Cancel
Start Time	SUN 12:00
Cycle	07 day
Flow Time	300 sec.
ON / OFF	OFF
	Time : MON 12:34
Auto Calibration Stop	

“Auto Calibration” screen

Example

In case where setting the auto calibration components (see Section 6.2.4) to “Ch1: enable” and “Ch2: enable”

• Zero calibration

A message, “Zero cal.” blinks at Ch1 and Ch2.

1	ZERO cal.	0.00	ppm
2	ZERO cal.	21.00	ppm
3	CV. NO _x 0-10	0.00	vol%
4	CV AV NO _x 0-10	0.00	1h ppm

• Ch1 span calibration

A message, “Span cal.” blinks at Ch1.

1	SPAN cal.	0.00	ppm
2	O ₂ 0-25	21.00	ppm
3	CV. NO _x 0-10	0.00	vol%
4	CV AV NO _x 0-10	0.00	1h ppm

• Ch2 span calibration

A message, “Span cal.” blinks at Ch2.

1	NO _x 0-10	0.00	ppm
2	SPAN cal.	21.00	ppm
3	CV. NO _x 0-10	0.00	vol%
4	CV AV NO _x 0-10	0.00	1h ppm

CAUTION

During auto calibration, any key operation is not permitted other than operations such as key lock ON/OFF and “Forced stop of auto calibration”.

When the key lock is set at ON, even the “Forced stop of auto calibration” cannot be performed.

To cancel “Auto Calibration” forcibly, set the key lock to OFF and then execute “Forced stop of auto calibration”.

6.5 Setting of auto zero calibration

6.5.1 Auto zero calibration

Auto zero calibration is automatically carried out at the time when zero calibration is set. Components for which a calibration is to be made are determined by setting of auto calibration component in Section 6.2.4.

Before changing the setting of auto zero calibration, set the ON/OFF to OFF.

- (1) Enter the "Setting of Auto Zero Check" screen from the user mode, and the display shown at right appears. Operate the $\hat{\circ}$ or the $\check{\circ}$ key until the cursor is aligned with a desired item and press the $\overset{\text{ENT}}{\circ}$ key.
- (2) In the "Setting of Auto Zero Check" screen that appears, perform the value entry or the setting. For the value entry or setting change, use the $\hat{\circ}$ or the $\check{\circ}$ key and the $\overset{\text{ENT}}{\circ}$ key to move the cursor to the right.

After setting, press the $\overset{\text{ENT}}{\circ}$ key, and auto zero calibration is carried out by the entered setting value.

Description of setting items

- Start Time : Setting at the first calibration (day of the week, hour, minute)
- Cycle : A period between the start time of one calibration and the next (unit : hour/day)
- Flow Time : The time required for the calibration gas to be replaced in the sampling cell
- ON/OFF : ON/OFF of auto zero calibration

To close "setting of Auto Zero Calibration"

To close the "Setting of Auto Zero Calibration" or cancel this mode midway, press the $\overset{\text{ESC}}{\circ}$ key. A previous screen will return.

Set Auto Zero Cal.	Select setting item
Start Time SUN 12:00 Cycle 07 day Flow Time 300 sec. ON / OFF OFF	
Time : MON 12:34	
Auto Zero Calibration Run	



Set Auto Zero Cal.	Set Start Time
Start Time SUN 12:00 Cycle 07 day Flow Time 300 sec. ON / OFF OFF	Press the $\hat{\circ}$ or the $\check{\circ}$ key, and date and time are displayed alternately.
Time : MON 12:34	
Auto Zero Calibration Run	



End of Auto Zero Calibration Setting

Auto calibration status contact output is closed during auto zero calibration (NO side), and is open in other cases.

Example

Start time	SUN	12:00
Cycle	12	hour
Flow time	300	sec
ON/OFF	ON	

In case where auto zero calibration is carried out at the above setting.

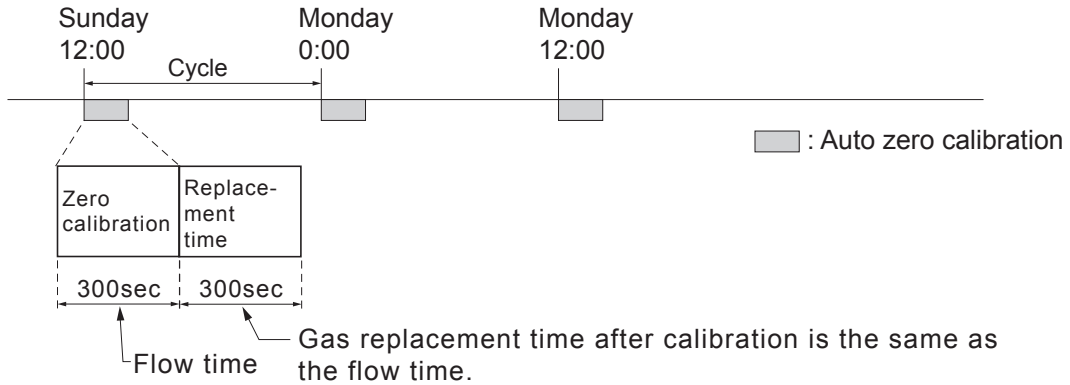

(An example of “Ch1 and Ch2: enable,” as given in Section 6.2.4 “Setting of auto calibration components/range”)

Setting range

Cycle : 1 to 99 hours or 1 to 40 days (initial value 7 days)
 Flow time : 60 to 900 sec (initial value 300 sec)

⚠ CAUTION

- When an auto zero calibration starts, the measurement screen automatically appears.
- During auto zero calibration, any key operation is not permitted other than operations such as key lock ON/OFF and “Forced stop of auto zero calibration” (see Section 6.5.2.2).
 When the key lock is set at ON, even the “Forced stop of auto zero calibration” cannot be performed. To cancel auto zero calibration forcibly, set the key lock to OFF and then execute “Forced stop of auto zero calibration”.
- Turn on the power again after it is turned off (including the case of power failure) at the time set as the next start time in auto zero calibration, and then repeat it in the set cycle.
- If the auto calibration period and auto zero calibration period have overlapped, the auto calibration is retained, ignoring the auto zero calibration of that period.
- When the hold setting is set to ON, the hold time of auto calibration contact and measurement value output signal are extended after calibration for gas replacement time.

Remote start

Whether the auto zero calibration is set at ON or OFF, an auto zero calibration is available by remote start input.

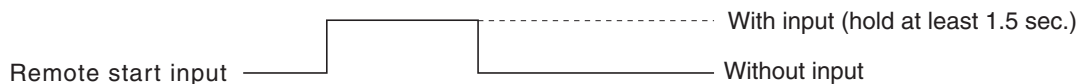

6.5.2 Forced run/stop of auto zero calibration

Auto zero calibration can be performed just once, or auto zero calibration can be forcibly stopped during calibration.

6.5.2.1 Execution of auto zero calibration (only once)

- (1) In the “Setting of Auto Zero Calibration” screen that appears, point the cursor to “Run” by pressing the $\hat{\circ}$ or the $\check{\circ}$ key. Press the ENT key.
- (2) “Run” is highlighted, displaying a message to confirm execution of auto zero calibration. Press the ENT key to execute the calibration, and press the ESC key to cancel.

Set Auto Zero Cal.	Auto Zero Run ENT : Run / Stop ESC : Cancel
Start Time	SUN 12:00
Cycle	07 day
Flow Time	300 sec.
ON / OFF	OFF
Time : MON 12:34	
Auto Zero Calibration Run	

6.5.2.2 Forced stop of auto zero calibration

This mode is used to cancel the auto zero calibration forcibly.

- (1) In the “Setting of Auto Zero Calibration” screen that appears, point the cursor to “Stop” by pressing the $\hat{\circ}$ or the $\check{\circ}$ key. Press the ENT key. (“Auto Zero Calibration Stop” appears when the screen is selected while auto zero calibration is performed.)
- (2) “Stop” is highlighted, displaying a message to confirm the stop of auto zero calibration. Press the ENT key to stop the auto zero calibration and the ESC key to cancel (not stopped).

Set Auto Zero Cal.	Auto Zero Stop ENT : Run / Stop ESC : Cancel
Start Time	SUN 12:00
Cycle	07 day
Flow Time	300 sec.
ON / OFF	OFF
Time : MON 10:56	
Auto Zero Calibration Stop	

“Auto Zero Calibration” screen

Example

In case where setting the auto calibration components (see Section 6.2.4) to “Ch1: enable” and “Ch2: enable”

- Zero calibration

A message, “Zero cal.” blinks at Ch1 and Ch2.

1	ZERO Check	0.05	ppm
2	ZERO Check	0.03	vol%
3	CV. NOx 0-10	0.00	ppm
4	CV. AV. NOx 0-10	0.00	1h ppm

 **CAUTION**

During auto zero calibration, any key operation is not permitted other than operations such as key lock ON/OFF and “Forced stop of auto zero calibration”.

When the key lock is set at ON, even the “Forced stop of auto zero calibration” cannot be performed.

To stop “auto zero calibration” forcedly, set the key lock to OFF and then execute “Forced stop of auto zero calibration”.

6.6 Parameter setting



It allows you to carry out the parameter setting such as time, key lock, etc., as required.

Items to be set are as follows:

Description of setting items



- Current Time : Current year, month, date, day of the week, hour, and minute setting
(The display appears in this order.)
Note) The clock backup time is 2 days. If power is turned on after it is kept off for 2 days or longer, check the time setting again.
- Key Lock : Invalidates any key operation except canceling the key lock.
- Output Hold : Sets whether measurement value output during calibration is held or not, and the holding value setting.
- Response time : Sets the response time of electrical system.
- Average Period : Sets the moving average time.
- Backlight Timer : Sets automatic OFF of the backlight of display unit and the time until backlight out.
- Contrast : Adjusts contrast of the LCD.
- Maintenance mode : Enters passwords to switch to the Maintenance mode.

* For the maintenance mode, see Section 6.7.

- (1) Enter the “Parameter setting” screen from the user mode, and the display shown at right appears. Operate the  or the  key until the cursor is aligned with a desired item and press the  key.

Parameter	Select setting item
<input checked="" type="checkbox"/> Current Time	12/01/11 WED 13:50
Key Lock	OFF
Output Hold	OFF Current
Response Time	
Average Period	
Backlight Timer	ON 05 min
Contrast	
To Maintenance Mode	0000



- (2) In the “Parameter Setting” screen that appears, perform the value entry or the setting. For the value entry or setting change, use the  or the  key, and the  key move the cursor to the right.

Parameter	Set day of week
Current Time	12/01/11 WED 13:50
Key Lock	OFF
Output Hold	OFF Current
Response Time	
Average Period	
Backlight Timer	ON 05 min
Contrast	
To Maintenance Mode	0000



To close Parameter Setting screen

To close the “Parameter Setting” screen or cancel this mode midway, press the  key. A previous screen will return.

End of Parameter Setting

Setting Range

- Hold setting : 0 to 100% FS
- Response time : 1 to 9 cycle (NDIR component) (Initial value: 1 cycle)
Detail of cycle is settable at <Maintenance mode>→<Sample switch Setting>→<Gas flow time>.
1 to 60 sec (O₂ sensor) (Initial value: 15 sec)
- Average period : 1 to 59 min or 1 to 4 hours (Initial value: 1 hour)
1 to 59 minutes when the unit is set to minute and 1 to 4 hours when it is set to hour.
- Backlight timer : 1 to 60 min (Initial value: 5 min)
- Maintenance mode : 0000 to 9999 (Initial value: 0000)

Output Hold

By setting an output hold to ON, an output signal of each channels are held during the manual/ auto calibration and for the gas flow time (refer to Section 6.4, Setting of Auto Calibration). Regardless of Hold ON/OFF setting, an output signal can be held via an external input.

a. Manual calibration

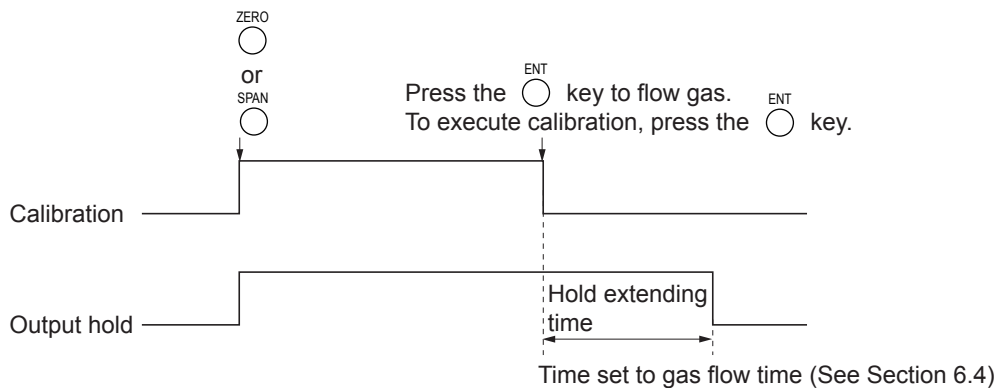

b. Auto calibration

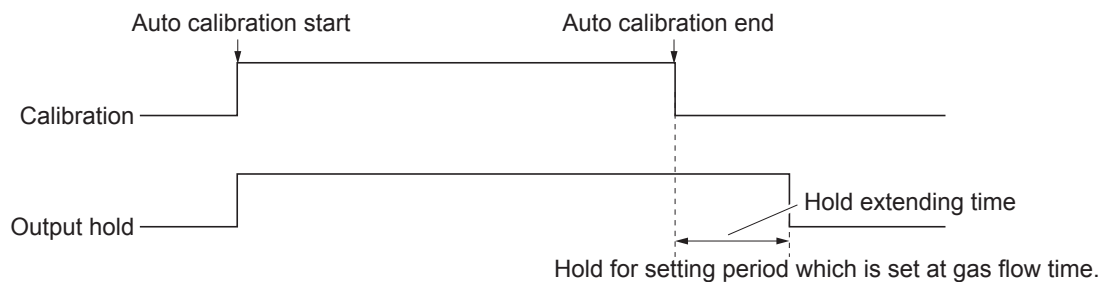

c. Remote hold

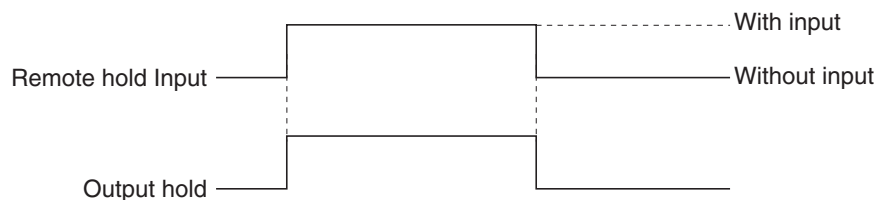





d. Screen display during Holding

The “Hold ON” message blinks on the measuring screen.

Since the screen displays the process of calibration during the manual/auto calibration, “Hold ON” is not displayed even if the output signal is held, but the screen is displayed with the hold extending time.



- e. If calibration is cancelled after the calibration gas is supplied regardless of manual or auto operation, the hold extending time will be performed.
- f. You can select the value for hold from the value immediately before entering output hold, “current,” and arbitrary value, “setting.”

Follow the procedures shown below to set.

- (1) In the “Parameter setting” screen that appears, select “Output Hold”.
 “ON” or “OFF” is highlighted by pressing the  key. Press the  or the  key to select ON/OFF. Press the  key to return to (1).



Parameter	Select Hold ON or OFF
Current Time	12/01/11 WED 13:50
Key Lock	OFF
Output Hold	ON Current
Response Time	
Average Period	
Backlight Timer	ON 05 min
Contrast	
To Maintenance Mode	0000







- (2) Where ON is highlighted, press the  key. “Current” or “Setting” is highlighted. Select “Current” or “Setting” by pressing the  or the  key.

Parameter	Select Hold setting
Current Time	12/01/11 WED 13:50
Key Lock	OFF
 Output Hold	ON Setting
Response Time	
Average Period	
Backlight Timer	ON 05 min
Contrast	
To Maintenance Mode	0000







- (3) Press the  key while “Current” is selected to return to (1). Press the  key while “Setting” is selected to go to the parameter hold screen.
 “Current”: Holds the value immediately before the hold.
 “Setting”: Holds the value arbitrarily set.

- (4) On the parameter hold screen that appears, move the cursor next to the Ch (component) you want to change by pressing the  or the  key, and then press the  key.

Parameter Hold	Select Ch No.
 Ch1	NOx 010 %FS
Ch2	O ₂ 022 %FS



(5) The value is highlighted, indicating that the value can be changed. Change the value by pressing the  or the  key, and then move the cursor to the right digit by pressing the  key.

(6) After the value is changed, press the  key.

Meaning of setting value

The setting is expressed as 1/1 full scale range for both respective ranges.

When 0 to 50 ppm is selected as the range, and 10% FS is selected as hold setting, the output equivalent to 5 ppm is held irrespective of the measurement value at that time.

(7) Press the  key to return to the parameter setting screen.

Description of setting

- Instantaneous measurement value that is displayed cannot be held. (Output only can be held.)
- Optional modbus communications “Measurement concentration” register values are held.
- If set value is selected for hold, instantaneous O₂ correction value is calculated and held based on the set value.
- Range identification contact output cannot be switched even if the range is switched during the hold.

Response time

The response time of the electrical system can be changed.

Setting is available by components.

Note) It does not provide exact seconds for the setting time, but it gives a guide of the setting time.

The setting value can be modified as requested by the customer.

↓ ENT

Parameter Hold	Set Hold value 0 to 100%FS		
Ch1	NOx	010	%FS
Ch2	O ₂	022	%FS

↓ ENT

End of Hold Setting

↓ ESC



Parameter Setting screen

Parameter Response Time	Select Ch No.		
 Ch1	NOx	1cycle0020Sec.	
Ch2	O ₂	22	Sec.

Average period

It allows you to set an averaging period of the average values of O₂ correction and O₂ average.

It enables you to set an average time of 1 to 59 minutes (1-minute step) or 1 to 4 hours (1-hour step).

Changing the setting also resets the averaging of O₂ correction and O₂ average value. (Pressing the  key resets averaging only for components whose setting was changed.)

Parameter	Select Ch No.		
Average Period			
<input checked="" type="checkbox"/> Ch3	AV. NOx	01	hour
Ch4	AV. O ₂	01	hour
Reset Av. Output		Reset	

Average value reset

This mode is used to clear all average values O₂ correction average and O₂ average, and restarts averaging. All average values are reset simultaneously. The indication value and output value is 0 ppm, vol% or so at the time of the reset input (based on average period settings).

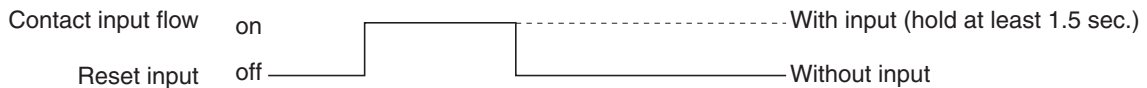

So long as with input, resetting lasts.

At the edge of changing from "with input" to "without input," the average action restarts.

Example of average action

In case the average period was set to 1 hour.

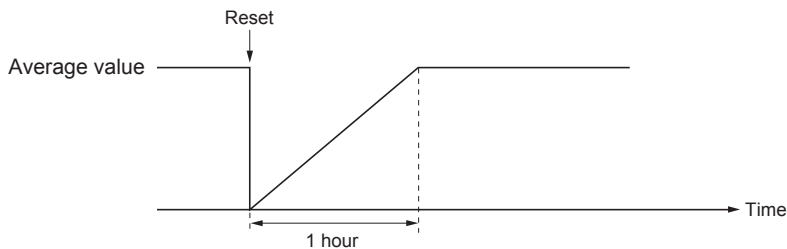





- Sampling occurs every 30 seconds.
- Every 30 seconds, the average for last 1 hour (time setting) is output.
- At the instant of resetting, zero is assumed for all past values. It means that the average value will not be correct for 1 hour after resetting.

Backlight Timer

Automatic OFF setting of the backlight of the LCD unit can be made.



When the specified time elapses during the measurement screen display with no key operation, the backlight is automatically turned off. Press any key to reset from backlight OFF.

Only when ON is selected, the time until auto OFF is displayed. Press the  key in this state, and the time setting can be changed by pressing the  or the  key. Press the  key to confirm the selection.

If OFF is selected, the backlight is not turned off.

Parameter	Set Backlight Timer ON or OFF
Current Time	12/01/11 WED 13:50
Key Lock	OFF
Output Hold	ON Setting
Response Time	
Average Period	
Backlight Timer	<input checked="" type="checkbox"/> ON 05 min
Contrast	
To Maintenance Mode	0000

Contrast

Contrast of the LCD can be adjusted. The contrast changes by pressing the  or the  key. Adjust to the best contrast and save it by the  key.



Parameter	
Current Time	12/01/11 WED 13:50
Key Lock	OFF
Output Hold	ON Setting
Response Time	
Average Period	
Backlight Timer	ON 05 min
Contrast	
To Maintenance Mode	0000

Maintenance mode

Enter the password and then press the  key to enter the maintenance mode. The password can be set by the password setting in maintenance mode. Default password setting at the time of delivery from the factory is "0000." You can enter the maintenance mode with this value before the password is changed.

6.7 Maintenance mode

This mode is used to check sensor input values, display of error log files or setting of passwords, etc. First, enter a password and then use it from the next operation. This mode is displayed by selecting the Maintenance Mode from Section 6.6 “Parameter Setting.”

- (1) Select the Maintenance Mode from the Parameter Setting screen to display the Password Setting screen.
- (2) Enter the password, and the Maintenance Mode item selection screen will be displayed. Point the cursor to the item you want to set by pressing the  or the  key and press the  key.
- (3) Next, each Maintenance screen is displayed.

Note) “To Factory Mode” is used for our service engineers only.

- (4) Press the  key to return to the Maintenance Mode item selection screen from each screen.

Maintenance Mode	Select operating item
<input checked="" type="checkbox"/> 1. Sensor Input Value 2. Error Log 3. Cal. Log 4. Output Adj. 5. Other Parameter 6. To Factory Mode	



Each “Maintenance” screen

• Sensor Input Value screen

Description of Sensor Input Value screen

- Input 1 : NDIR sensor digital value
- Input 2 : O₂ sensor digital value

Maintenance Sensor Input	ENT : Selectable flow gas
Input 1	500821
Input 2	11050
<input checked="" type="checkbox"/> GAS Sample	

• Error Log screen

Description of Error Log screen

Error history. 14 newest errors are logged. For error number, date and time (year, month, day, period) of occurrence, channel and other details of error, refer to Section 8 “Error message”. Select Clear Error Log and press the  key, and the error log is cleared completely.

Maintenance Error Log	ENT : Clear Error Log ESC : Back					
error No.	YY	MM	DD	HH	MM	Ch
No. 10	15	9	8	13	5	
No. 9	15	6	17	10	40	5
No. 5	15	6	17	10	40	5
No. 9	15	6	17	10	40	1
No. 5	15	6	17	10	36	1
No. 7	15	6	17	10	33	1
No. 7	15	5	26	16	40	2
Next page						Page1
<input checked="" type="checkbox"/> Clear Error Log						

• Calibration Log screen

Description of Calibration Log screen

Past calibration history is displayed.
 Sensor input value, concentration value, and the date when zero/span calibration is performed are logged. The 10 newest calibration data are logged by each component.

Move the cursor to Clear Calibration Log and press the  key, and the calibration log is cleared completely.

Z1 : Zero calibration (Z) of Range 1

S1 : Span calibration (S) of Range 1

Cnt : Value of measuring detector at the time of calibration

Con : Concentration value displayed before calibration

Maintenance Mode Cal. Log	Select Ch No.
<input checked="" type="checkbox"/> Ch1 NOx <input type="checkbox"/> Ch2 O2	
Clear Cal. Log	









Maintenance Cal. Log Ch1 NOx						
R	Cnt	Con	M	D	H	M
S2	504891	94.42	5	28	21	50
Z1	499859	0.00	5	27	9	24
Z1	499861	0.12	5	26	16	28
S2	500124	97.50	5	26	16	17
Z1	503703	0.25	2	2	14	23
Z1	503712	0.00	2	2	14	7
Z1	503712	0.00	2	2	14	7
S1	503686	9.40	2	2	14	7
Z1	490908	0.00	2	2	14	3
Z1	500655	-1.32	2	2	14	3

• **Output adjustment screen**

Description of output adjustment screen

Analog output adjustment screen.
Connect the digital multi meter to the output terminal corresponding to the number of OUT to be adjusted, and adjust the value so that 4mA or 0V is output at zero and 20mA or 1V is output at span.

Move the cursor using the , , or the  key to the output (OUT No. and zero/span) to be adjusted, and then press the  key.

The selected value is highlighted. Adjust the value, while watching the output, by pressing the  or the  key. Press the  key to select the next digit.

On completion of the adjustment, press the  key.

Maintenance Mode Output Adj.			Adjust OUTPUT ZERO and SPAN		
OUT	Zero	Span	OUT	Zero	Span
1	00600	03700	7	00600	03700
2	00600	03700	8	00600	03700
3	00600	03700	9	00600	03700
4	00600	03700	10	00600	03700
5	00600	03700	11	00600	03700
6	00600	03700	12	00600	03700





Maintenance Mode Output Adj.			Zero/Span adjustment		
OUT	Zero	Span	OUT	Zero	Span
1	00600	03700	7	00600	03700
2	00600	03700	8	00600	03700
3	00600	03700	9	00600	03700
4	00600	03700	10	00600	03700
5	00600	03700	11	00600	03700
6	00600	03700	12	00600	03700

• **Other parameter**



Description of each setting screen

- Password Set** : Set the password used to move from the parameter setting screen to the maintenance mode. Arbitrary 4-digit number can be selected.
- O₂ ref. Value** : Set the oxygen concentration reference value at the time of oxygen correction calculation. Settable in the range from 00 to 19%.
- Limit** : Set the oxygen concentration limit at the time of oxygen correction calculation. Settable in the range from 01 to 20%.
- * Refer to the O₂ correction concentration value in Section 5.3 “Outline of display screen” for oxygen correction calculation procedure.
- Station No.** : Set the station No. for MODBUS communication. Settable in the range from 00 to 31.
- Range setting** : Set or change the measuring range.
- Set Sample Switching** : Set or change parameters about Sample Switching.

Maintenance Mode Setting	Set Password
	Password Set 2465 O ₂ ref. Value 12% O ₂ limit 20% O ₂ Station No. 01 Range Setting Set Sample Switching

Press the  or the  key to move the cursor to the item whose setting is to be changed.

The values for password, oxygen correction, limit, and station No. are highlighted.



Press the  or the  key to change the value to desired one, and then press the  key.



 **CAUTION**



Pay attention not to forget the password. Otherwise you cannot enter the maintenance mode.

<How to set/change the range>

The measuring range can be arbitrarily selected in the minimum and the maximum range specified at the time of purchase. The range number to be used can be selected 1 or 2.

- (1) Move the cursor to the item to be set by pressing the  or the  key, and then press the  key.



- (2) Move the cursor to the Ch (component) whose setting is to be changed by pressing the  or the  key, and then press the  key.



- (3) Move the cursor to the item whose setting is to be changed by pressing the  or the  key, and then press the  key.

Settable range

The value for range 1 and range 2 must fall within the range from the MIN and the MAX range (including the MIN and the MAX range), and at the same time range 1 must be smaller than range 2.

The number of ranges is 1 or 2.

- (4) Press the  or the  key to change the value. Press the  key to select the next digit. The unit cannot be changed.

In a state where the decimal point is highlighted, press the  or the  key, and the decimal point position can be changed.

- (5) When necessary change is made, press the  key.

Maintenance Mode Setting	Select operating item
Password set 2465 O ₂ ref. Value 12% O ₂ limit 20% O ₂ Station No. 01 <input checked="" type="checkbox"/> Range Setting Set Sample Switching	



Maintenance Mode Range set	Select Ch No.
<input checked="" type="checkbox"/> Ch1 NO _x Ch2 O ₂	



Maintenance Mode Range set Ch1 NO _x	Select range or range num.
MIN range 10.00 ppm Range 1 20.00 ppm Range 2 60.00 ppm <input checked="" type="checkbox"/> MAX range 100.0 ppm Range num. 2	

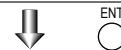

Maintenance Mode Range set Ch1 NO _x	Set range
MIN range 10.00 ppm Range 1 20.00 ppm Range 2 60.00 ppm MAX range 100.0 ppm Range num. 2	

CAUTION

Be sure to perform zero / span calibration when the range setting is changed. Otherwise, the measurement value may not be output properly.

6.7.1 Sample switch setting

Set up the setting for the required operation of sample switch. Set up the gas flow time and interference compensation coefficients.

6.7.1.1 How to change the setting of gas flow time

- (1) Select the Sample Switch Setting from the Maintenance Mode, and the display shown at right appears.

Maintenance Mode Sample Switch	Select operating item
<input checked="" type="checkbox"/> Gas Flow Time Interference Coefficient (meas.) Interference Coefficient (cal.)	



- (2) When the gas flow time is chosen on the sample switch setting, screen will be appeared as shown on the right.

Selectable a switching time and flow time of the reference gas with key operation.

Maintenance Mode Sample Switch Gas Flow Time	Select operating item
<input checked="" type="checkbox"/> REF. Gas: Replacement Time 05 sec REF. Gas: Measuring Time 05 sec REF. Gas: Flowing Time 10 sec SMP. Gas: Replacement Time 05 sec SMP. Gas: Measuring Time 05 sec SMP. Gas: Flowing Time 10 sec	

- (3) Settable the each setting time by pressing  key. Refer to the “explanation” below regarding setting range.

Maintenance Mode Sample Switch Gas Flow Time	Set the gas replacement time. 1 to 30 sec
REF. Gas: Replacement Time	05 sec
REF. Gas: Measuring Time	05 sec
REF. Gas: Flowing Time	10 sec
SMP. Gas: Replacement Time	05 sec
SMP. Gas: Measuring Time	05 sec
SMP. Gas: Flowing Time	10 sec



- (4) When press the  key, the cursor will be returned and setting value will be memorized. Also switching time and measuring time of the sample gas are set automatically based on following relational expression.

Note: This setting time is very important setting when sample switch is carried out. Do not change the setting time unless it is required.

Maintenance Mode Sample Switch Gas Flow Time	Select operating item
<input checked="" type="checkbox"/> REF. Gas: Replacement Time	05 sec
REF. Gas: Measuring Time	05 sec
REF. Gas: Flowing Time	10 sec
SMP. Gas: Replacement Time	05 sec
SMP. Gas: Measuring Time	05 sec
SMP. Gas: Flowing Time	10 sec

Explanation

Set up switching time and measuring time of the reference gas.

Switching time of reference gas : 1 to 30s (Initial value 5 sec)

Measuring time of reference gas : 1 to 60s (Initial value 5 sec)

Note) Switching time of the sample gas, measuring time of the sample gas, flow time of the reference gas and flow time of the sample gas are updated automatically based on following relational expression.

Switching time of sample gas (t1) = Switching time of reference gas (t3)

Measuring time of sample gas (t2) = Measuring time of reference gas (t4)

Flow time of sample gas (Ts) = Flow time of reference gas (Tr)

Flow time of reference gas (Tr) =

Switching time of reference gas (t3) + measuring time of reference gas (t4)

Flow time of sample gas (Ts) =

Switching time of sample gas (t1) + measuring time of sample gas (t2)

1 cycle = flow time of reference gas (Tr) + flow time of sample gas (Ts)

6.7.1.2 Interference compensation coefficient

- (1) Select the Sample Switch Setting from the Maintenance Mode, and the display shown at right appears.

Maintenance Mode Sample Switch	Select operating item
<input checked="" type="checkbox"/> Gas Flow Time Interference Coefficient (meas.) Interference Coefficient (cal.)	



- (2) When the interference compensation coefficient is chosen on sample switch setting, the screen will be appeared as shown on the right.

Select the interference compensation coefficient for each desired Ch. to be set with key operation.

When the key is pressed, screen will be moved to interference compensation value.

Maintenance Mode Sample Switch Interference (c)	Select Ch No.
<input checked="" type="checkbox"/> Ch1 NOx	393 1.000000
Ch2 SO ₂	184 1.000000
Ch3 CO ₂	-10 1.000000
Ch4 CO	656 1.000000

- (3) When key is pressed after changing the parameter value, the cursor will be returned and setting value will be memorized.

6.7.1.3 Explanation of sample switch method

Flow time of reference gas and sample gas are switched by sample switch method at the following timing.

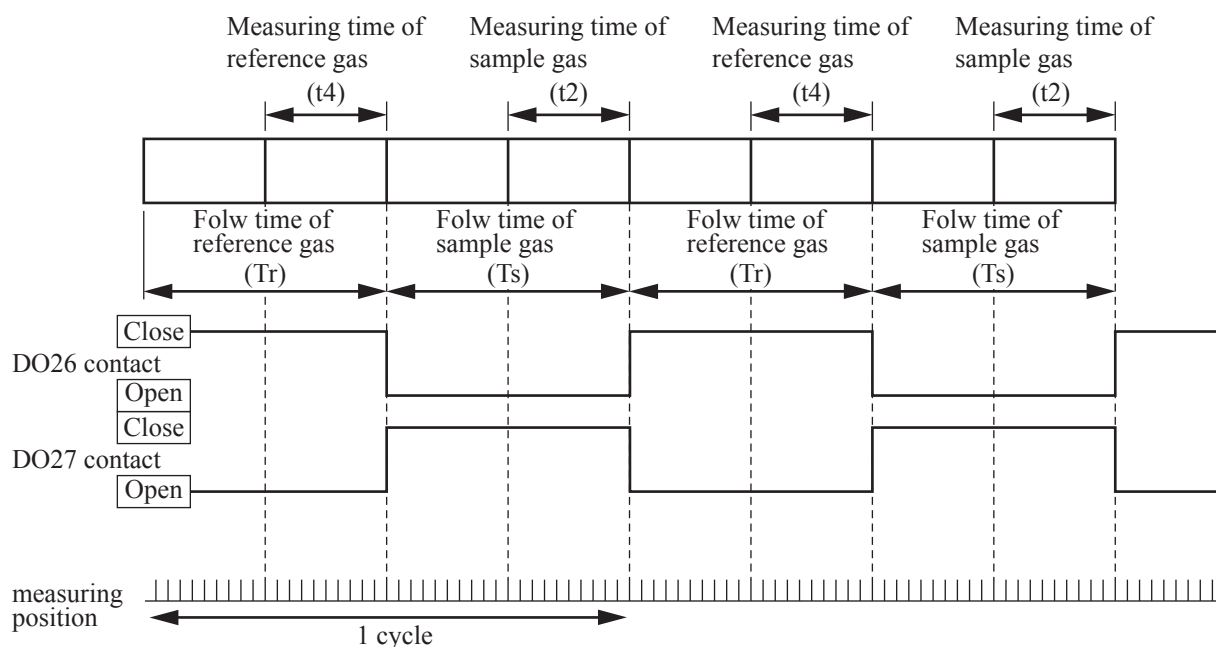

Switching time of reference gas : 1 to 30s (Initial value 5 sec)

Measuring time of reference gas : 1 to 60s (Initial value 5 sec)

Note) Switching time of the sample gas, measuring time of the sample gas, flow time of the reference gas and flow time of the sample gas are updated automatically based on following relational expression.

Switching time of sample gas (t1) = Switching time of reference gas (t3)

Measuring time of sample gas (t2) = Measuring time of reference gas (t4)

Flow time of sample gas (Ts) = Flow time of reference gas (Tr)

Flow time of reference gas (Tr) =

Switching time of reference gas (t3) + measuring time of reference gas (t4)

Flow time of sample gas (Ts) =

Switching time of sample gas (t1) + measuring time of sample gas (t2)



1 cycle = flow time of reference gas (Tr) + flow time of sample gas (Ts)

6.8 Manual calibration procedure

6.8.1 manual zero calibration

It is used for zero point adjustment. Proper zero gas, suitable for the application, should be used. Refer to Section 3.4.3 “Preparation of standard gas”.

- Press the  key on the Measurement screen to display the Manual Zero Calibration screen.

- Select the Ch (component) to be calibrated by pressing the  or the  key. After selection, press the  key, and zero gas will be supplied.

Note

For the Ch (components) in which “at once” is set in the zero calibration (see Section 6.2.2) - zero calibration is carried out simultaneously. And for the Ch (components) in which “both” is set in the calibration range setting (see Section 6.2.3) - zero calibration is carried out on both ranges.

- Wait until the indication is stabilized with the zero gas supplied. After the indication has been stabilized, press the  key. Zero calibration in range selected by the cursor is carried out.

Note: For the Ch (component) for which “AR” is selected in Section 6.1.1 “Setting of range switch mode,” the cursor automatically moves to the range selected in “Setting of auto calibration component/range” (Section 6.2.4), and calibration is carried out within that range.

To close "Zero Calibration"

To close the “Zero Calibration” or cancel this mode midway, press the  key. A previous screen will return.

Measurement mode screen



ZERO Cal.		Select Ch No. with UP / DOWN and ENT Back with ESC	
<input checked="" type="checkbox"/> Ch1 NOx	▶ Range 1 0-10.00 ppm Range 2 0-100.0 ppm		0.0
<input checked="" type="checkbox"/> Ch2 O ₂	▶ Range 1 0-10.00 vol% Range 2 0-25.00 vol%		20.09



ZERO Cal.		Select Ch No. with UP / DOWN and ENT Back with ESC	
<input checked="" type="checkbox"/> Ch1 NOx	▶ Range 1 0-10.00 ppm Range 2 0-100.0 ppm		0.0
<input checked="" type="checkbox"/> Ch2 O ₂	▶ Range 1 0-10.00 vol% Range 2 0-25.00 vol%		20.09



ZERO Cal.		ENT : Go on calibration of selected Ch. ESC : Not calibration	
Ch1 NOx	▶ Range 1 0-10.00 ppm Range 2 0-100.0 ppm	<input checked="" type="checkbox"/>	0.0
Ch2 O ₂	▶ Range 1 0-10.00 vol% Range 2 0-25.00 vol%	<input checked="" type="checkbox"/>	20.09



To Measurement screen after
executing Manual Zero Calibration

6.8.2 Manual span calibration

It is used to perform a span point adjustment. Supply calibration gas with concentration set to the span value to perform the span calibration. For the span calibration gas for the NO_x, SO₂, CO₂ and CO measurement, use the standard gas with a concentration of 90 to 100% of its measuring range value. For the span calibration gas for the O₂ measurement, use the standard gas with a concentration of 90 to 100% of its measuring range value when measuring with the built-in O₂ sensor, and use the standard gas of 1 to 2 vol% when measuring with an external zirconia O₂ sensor.

- Press the  key on the Measurement screen to display the Manual Span Calibration screen.

Measurement mode screen



SPAN Cal.		Select Ch No. with UP / DOWN and ENT Back with ESC	
<input checked="" type="checkbox"/> Ch1 NOx	▶ Range 1 0-10.00 ppm Range 2 0-100.0 ppm		0.0
Ch2 O ₂	▶ Range 1 0-10.00 vol% Range 2 0-25.00 vol%		20.09





SPAN Cal.		Select Ch No. with UP / DOWN and ENT Back with ESC	
<input checked="" type="checkbox"/> Ch1 NOx	▶ Range 1 0-10.00 ppm Range 2 0-100.0 ppm		0.0
Ch2 O ₂	▶ Range 1 0-10.00 vol% Range 2 0-25.00 vol%		20.09



SPAN Cal.		ENT : Go on calibration of selected Ch. ESC : Not calibration	
Ch1 NOx	▶ Range 1 0-10.00 ppm Range 2 0-100.0 ppm	<input checked="" type="checkbox"/>	9.8
Ch2 O ₂	▶ Range 1 0-10.00 vol% Range 2 0-25.00 vol%		20.09



To Measurement screen after executing Manual Span Calibration

- Select Ch (component) to be calibrated by pressing the  or the  key and press the  key. The calibration gas is supplied.

Note

For the Ch (components) in which “both” is set in the calibration range setting (Refer to Section 6.2.3) - span calibration is carried out for both ranges.

- Wait until the indication is stable. After the indication has been stabilized, press the  key. Span calibration of Range selected by the cursor is performed.

Note: For the Ch (component) for which “AR” is selected in Section 6.1.1 “Setting of range switch mode”, the cursor automatically moves to the range selected in “Setting of auto calibration component/range” (Section 6.2.4), and calibration is carried out within that range.

To close "Span Calibration"

To close the “Span Calibration” or cancel this mode midway, press the  key. A previous screen will return.

7. MAINTENANCE

7.1 Daily check

(1) Zero calibration and span calibration

- (1) Perform zero calibration. For the calibration procedures, refer to Section 6.8.1 “Manual zero calibration.”
- (2) Then, perform span calibration. For the calibration procedures, refer to Section 6.8.2 “Manual span calibration.”
- (3) Zero/span calibration should be carried out once a week, or as required.

(2) Flow rate check

- (1) Flow rate of sample gas, reference gas and purge gas are as follows:
 - Sample gas flow : 1.0L/min \pm 0.2L/min
 - Reference gas flow : 1.0L/min \pm 0.2L/min
 - Purge gas flow : About 1L/min
- (2) Check and maintenance should be carried out every day, or as required.

7.2 Daily check and maintenance procedures

Table 7.1 Maintenance and check table

	Parts to be checked	Phenomena	Cause	Remedy
Daily check	Indication value	Indication values are too low. Indication values are too high.	(1) Dust contamination in sampling cell.	(1) Clean the sampling cell. In addition, check sampling devices, especially gas filter.
			(2) Air is absorbed midway in the sampling piping.	(2) Find out cause of leak and repair.
	Flow rate of sampling gas, reference gas and purge gas (Purge gas flow is included when purging).	Deviation from regulated flowing quantity (0.8L/min to 1.2L/min).	_____	Adjust by needle valve of flow rater.
Weekly check	Zero point of gas analyzer	Deviation from zero point.	_____	Zero adjustment
	Span point of gas analyzer	Deviation from span point.	_____	Span adjustment
Yearly check	Gas analyzer	Regardless of any phenomena		Overhaul or service in accordance with proper service plan.

7.3 Long term maintenance

Create a long-term maintenance component procurement plan based on the “Gas analyzer annual inspection plan” indicated below.

Gas analyzer annual inspection plan

The recommended replacement period of components varies depending on the installation conditions.

- 1) The recommended replacement period is a recommended standard criterion, and varies depending on the environment of the field, conditions of measuring gas and other factors.
- 2) The recommended replacement period is not the warranty period. It is provided as a preventative maintenance program baseline schedule.

• Installation conditions

- 1) Ambient temperature: -5°C to $+45^{\circ}\text{C}$
- 2) Humidity: 90%RH or less
- 3) Corrosive gases: None
- 4) No radiated heat, direct sunlight or rain/wind
- 5) Dust: No more than local environmental standards permit
- 6) Vibration: None

• Sample gas conditions

- 1) Flow rate: $1.0 \pm 0.2\text{L} / \text{min}$
- 2) Temperature: 0 to 50°C
- 3) Dust: $100 \mu\text{g}/\text{Nm}^3$ or less in particle size of $0.3 \mu\text{m}$ or smaller
- 4) Mist: Unallowable
- 5) Moisture: For CO, NO, SO₂ measurement: less than 2°C saturation point.

For CO₂ measurement: less than -30°C saturation point (with comparable moisture levels in sample and reference gases).

Please consult with us regarding gas analyzer maintenance service requirements.

We may assist in providing access and support via a qualified service network.

No.	Component name	Q'ty	Recommended replacement period (year)	Year										
				Delivered year	1st year	2nd year	3rd year	4th year	5th year	6th year	7th year	8th year	9th year	10th year
1	Fuel cell O ₂ analyzer (build-in)	1	2			○		○		○		○		○
2	Infrared light source	1	8									○		
3	O-ring for sampling cell	2	2			○		○		○		○		○
4	Detector B (NO, SO ₂)	1	8									○		
5	Detector A (CO, CO ₂)	1	8									○		
6	LCD	1	3				○			○			○	
7	Solenoid Valve	2	3				○			○			○	
8	Main power supply unit	1	5						○					○
9	SSW power supply unit	1	5						○					○
10	Main power PCB	1	5						○					○
11	Light source power PCB	1	5						○					○
12	AC/DC power supply unit	3	5						○					○

7.4 Cleaning of sampling cell

Entry of dust or water drops in the sampling cell contaminates the interior of the cell, thus resulting in a drift. Clean the inside if dirty. Then, check the sampling device, especially the filter, to prevent the cell from being contaminated by dust or mist.

CAUTION

Maintenance actions should only be accomplished by properly trained and qualified personnel. Notwithstanding these maintenance steps, local facility and organizational safety program requirements must be followed.

7.4.1 Disassembly and assembly of sampling cell

There is just one kind of sampling cell and it is called pipe cell (Cell length: 250 mm and 300 mm).

a. How to remove pipe cell (See Fig. 7-1)

- 1) Stop measured gas. If it is harmful, purge the pipe cell thoroughly with zero gas.
- 2) Turn OFF the power switch and disconnect the Power supply cord.
- 3) Remove the cover (with loose 6 screws on the top/front panel).
- 4) Remove the tube connected to the pipe cell.
- 5) Loosen and remove a screw (No. 7) from the cell retainer (No. 11) fastening the pipe cell (bothends).
- 6) Remove the cell from the measuring unit and unscrew the infrared transmission window (No. 14) at both ends in the right direction.
- 7) For assembly, reverse the disassembly procedure and make sure to put the space in 0.5mm between light source unit and measuring cell and detector.

In addition screw the window (No. 14) on the both side to the measuring cell with matching the pipe part and marked part of measuring cell.

<Horizontal type>

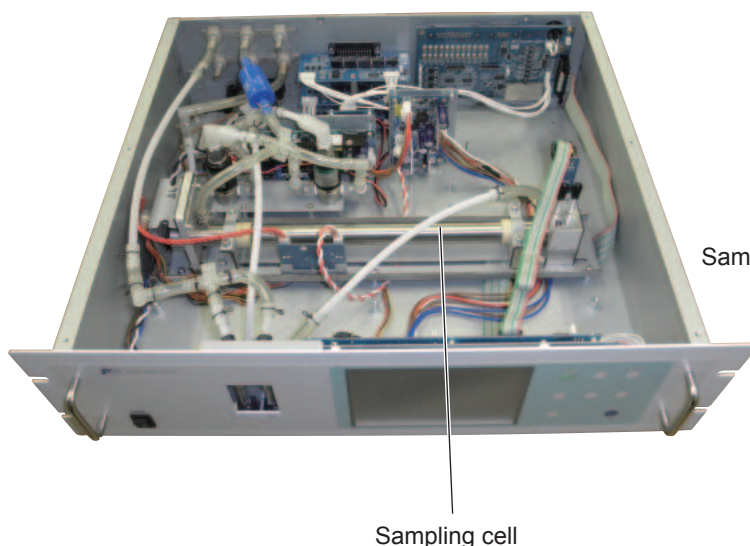

<Vertical type>



No.	Name
1	Screw (for fixing the light source unit)
2	Screw (for fixing the detector)
3	
4	Base plate
5	Light source unit
6	Screw (for fixing the support)
7	Screw (for fixing the cell retainer)
8	Gas filter
9	Filter
10	Support
11	Cell retainer
12	Pipe cell
13	O-ring
14	Infrared ray transmission window
15	Detector
16	Light source power PCB

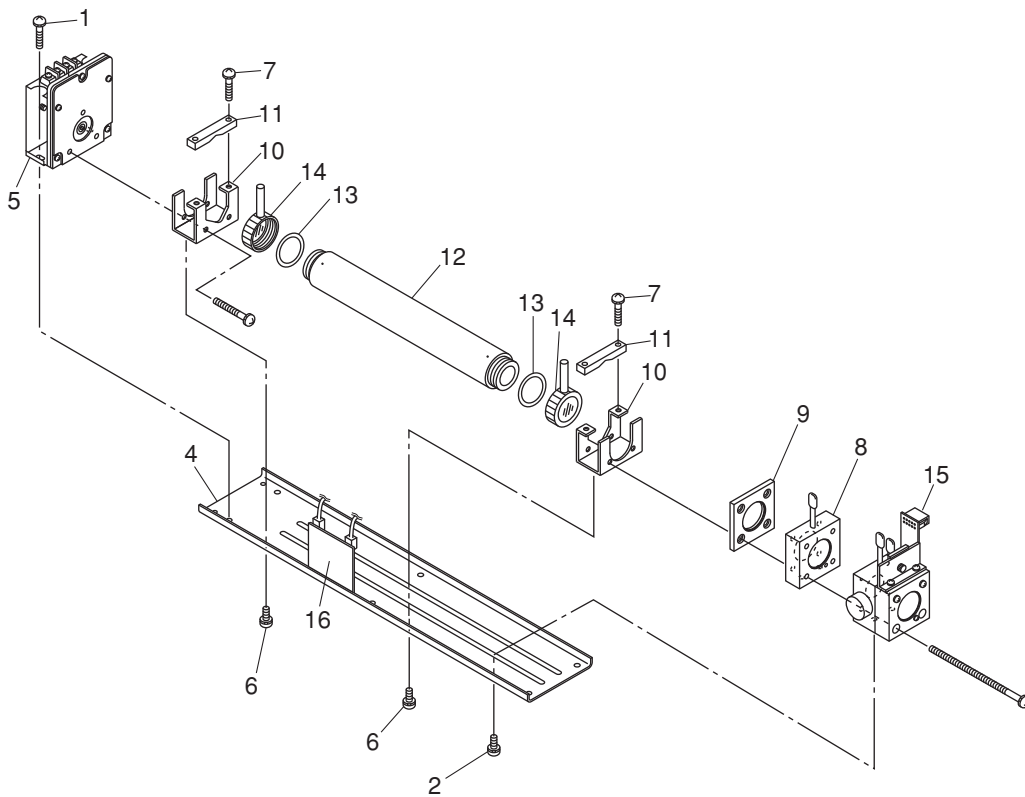

Fig. 7-1 Configuration of measuring unit (pipe cell)

7.4.2 How to clean sampling cell

- 1) To clean the sampling cell inside or infrared ray transmission window, first clear large dirt of it with a soft brush and then wipe lightly with soft cloth.
Do not use abrasive or paper cloth.

Note) Handle the fragile window with care. Use care not to rub off the dirt from the window roughly.

- 2) If the window or the sampling cell interior is very dirty, use a soft lint-free cloth moistened with absolute alcohol.
- 3) If the window is corroded, rub off the scale from the window lightly with a soft cloth to which chrome oxide powder is applied. If it is excessively corroded, it should be replaced with new one.
- 4) When the sampling cell or window cleaning is completed, assemble according to the sampling cell disassembly and assembly procedures. Assemble the pipe carefully. If it becomes bent or damaged, replace it with a new part.
- 5) Do not wash the sample cell components with water.

7.5 Replacement of fuse

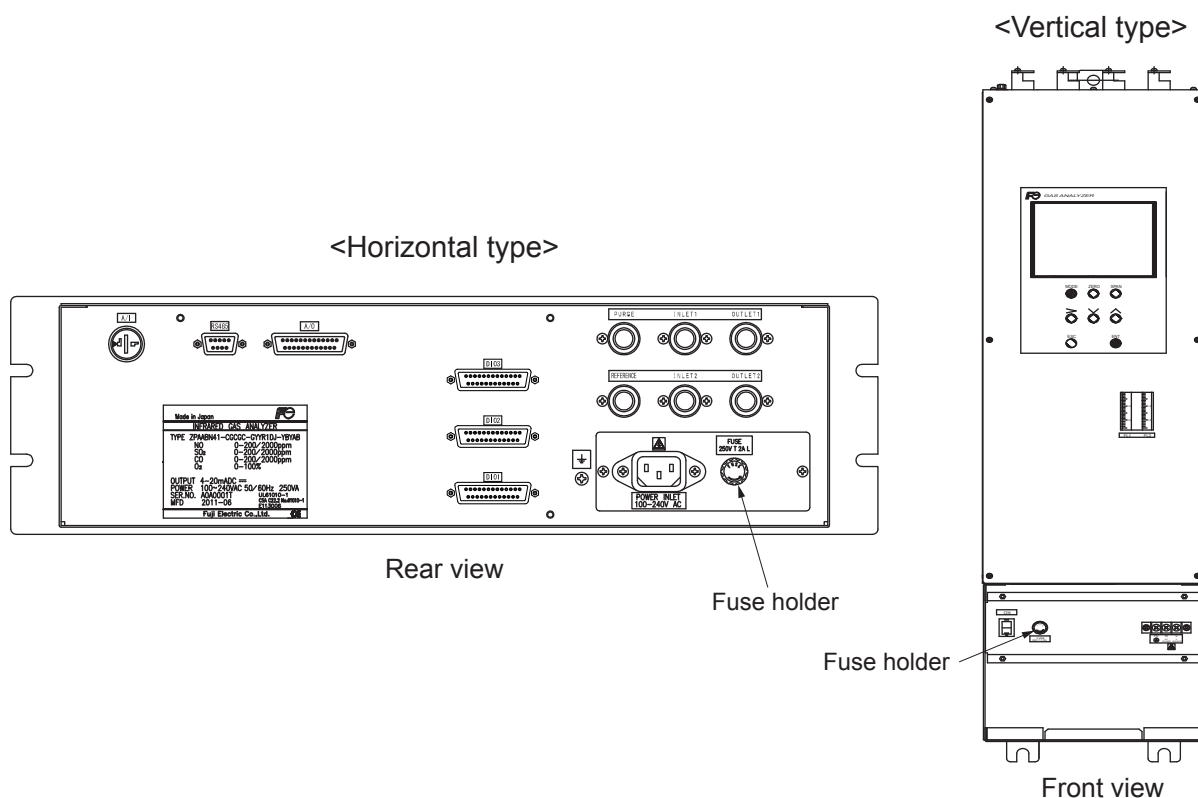

Note) Prior to the following work, be sure to repair blown down fuse (short, etc), if any.

- (1) Turn "OFF" the main power supply switch to the analyzer.
- (2) Turn the fuse holder cap (shown in the figure above) counterclockwise and pull it out, and the cap will be removed. Remove a fuse out of the holder. Replace it with a new one. (250VAC/2A, Time-lag type).
- (3) Reinstall the fuse holder cap, turn ON the power supply switch. The work will be completed if the analyzer starts up normally.

8. ERROR MESSAGE

If errors occur, the following contents are displayed.

Error display	Error contents	Probable causes
Error No.1	Light source/motor rotation is faulty.	<ul style="list-style-type: none"> • Infrared light source is faulty. • Sector motor is not properly run or is stopped. • Amplifier circuit is faulty.
Error No.2	Detector failure	<ul style="list-style-type: none"> • Detector voltage circuit is faulty. • Detection element is broken or faulty. • Amplifier circuit is faulty.
Error No.3	A/D error	<ul style="list-style-type: none"> • A/D conversion circuit is failure.
Error No.4	Zero calibration is not within the allowable range.	<ul style="list-style-type: none"> • Zero gas is not supplied. • Zero error due to dirty cell. • Detector is faulty.
Error No.5	Amount of zero calibration (indication value) is over 50% of full scale.	
Error No.6	Span calibration is not within the allowable range.	<ul style="list-style-type: none"> • Span gas is not supplied. • Calibrated concentration setting does not match cylinder concentration. • Zero calibration is not performed normally. • Span error due to dirty cell. • Detector sensitivity has deteriorated.
Error No.7	Amount of span calibration (difference between indication value and calibrated concentration) is over 50% of full scale.	
Error No.8	Measured values fluctuate too much during zero or span calibration.	<ul style="list-style-type: none"> • Calibration gas is not supplied. • Time for flowing calibration gas is short.
Error No.9	Calibration is abnormal during auto calibration.	<ul style="list-style-type: none"> • Error corresponding to No. 4 to No. 8 occurred during auto calibration.
Error No.10	Output cable connection is improper.	<ul style="list-style-type: none"> • DIO circuit is failure. • Internal wiring to the DIO circuit is broken.

When errors No. 1 to No. 3 and No. 10 occur, instrument error (FAULT) contact output is closed.

When errors No. 4 to No. 9 occurs, calibration error contact output is closed.

<Troubleshooting at the occurrence of error>

When error No.1 occurs, remove the top/front cover of the analyzer and check the LED on the light source power PCB. If LED light is turned off, this has been caused by disconnection of the light source.

When errors No. 1 to No. 3 and No. 10 occurs, the analyzer is faulty. Contact your dealer or our sales office.

When errors No. 4 to No. 8 occurs, the calibration procedure may be incorrect.

Check the following items, and if error still occurs, contact us as shown above.

- (1) Is the calibration gas supplied in the analyzer?
- (2) Does the calibration operation match the supplied gas? (For example, zero calibration is performed while flowing the span gas.)
- (3) Does the supplied gas concentration match the gas concentration set at the calibration concentration setting?

Also, when errors No. 5 and No. 7 occurs, you can perform calibration forcibly, following the procedure shown below. Use it as fault recovery when calibration fails and calibration contents are missed.

Screen display and operation at the occurrence of error

In case of Error No. 1 to No. 4, No. 6, No. 8 to No. 10

Measurement screen

Error No.9	0.08	ppm
2 Ch O ₂ 0-25	21.00	vol%

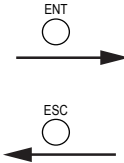

Display of error contents

Error No. 9	Auto Cal. error ESC : Back to MEAS.
SPAN NOx Calibration error Cause	
<ul style="list-style-type: none"> • Calibration gas is not flowing • Gas flowing time is short • Setting conc. is different from gas conc. • Dirt in sample cell 	

- Press the key to delete the error display.
- If the key is pressed without removing the cause of an error, the error will be displayed again.

- When more than one error occurs, pressing the key moves to another error display.

In case of Error No. 5 and No. 7

ZERO Cal.	ENT : Go on calibration of selected Ch. ESC : Not calibration		
Ch1 NOx	▶ Error No. 5	ppm ppm	◀ 3083
Ch2 O ₂	▶ Range 1 0-10.00 Range 2 0-25.00	vol% vol%	-0.09

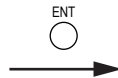

Error No. 5	ZERO cal. error ENT : Force Cal. ESC : Stop cal. and back to MEAS.
NOx Calibration error Cause	
<ul style="list-style-type: none"> • Zero gas is not flowing • Dirt in sample cell • Low sensitivity of detector 	

- Pressing deletes the error display.



Calibrated forcedly

Calibration is continued. Unless another calibration error occurs, calibration is carried out to the end, and the measurement screen returns.



1 Ch NOx 0-10.00	0.08	ppm
2 Ch O ₂ 0-25	0.09	vol%

Error log file

If error occurs, the history is saved in an error log file. The error log file exists in the maintenance mode.

Error log screen

Maintenance Error Log

ENT : Clear Error Log
ESC : Back

error No.	YY	MM	DD	HH	MM	Ch
No. 10	15	9	8	13	5	
No. 9	15	6	17	10	40	2
No. 5	15	6	17	10	40	2
No. 9	15	6	17	10	40	1
No. 5	15	6	17	10	36	1
No. 7	15	6	17	10	33	1
No. 7	15	5	26	16	40	2

Next page Page1

Clear Error Log

Annotations:
- Date and time when an error occurred. (points to the date and time columns)
- Component for which the error occurred. (points to the 'Ch' column)
- Errors that occurred (points to the 'error No.' column)
- New/Old (vertical arrows on the right side of the table)

* Up to 14 errors can be saved in the error history; the oldest error will be deleted one by one every time a new error occurs.

* If the power supply is turned OFF, the contents in the error log file will not be lost or damaged.

Deletion of error history

Press the ENT key on the above screen, and the “Error Log Clear” will be highlighted. Further pressing the ENT key will clear the error history.

9. SPECIFICATIONS

9.1 General specifications

1. Standard Specifications

Principle of measurement:

- NO, SO₂, CO₂, CO;
 Non-dispersion infrared-ray absorption method (NDIR method)
 Single light source and single beams (single beam system)
- O₂ ;Fuel cell O₂ analyzer (built in) or paramagnetic O₂ analyzer (built-in) or zirconia O₂ analyzer (externally installed TYPE: ZFK7)

Measurable gas components and measuring range:

	Minimum range	Maximum range
NO	0 - 10ppm	0 - 100ppm
SO ₂	0 - 10ppm	0 - 100ppm
CO ₂	0 - 5ppm	0 - 50ppm
CO	0 - 5ppm	0 - 50ppm
O ₂ (built in fuel cell)	0 - 10vol%	0 - 25vol%
O ₂ (built-in Paramagnetic)	0 - 5vol%	0 - 100vol%
O ₂ (External Zirconia)	0 - 5vol%	0 - 25vol%

- Max. 2 components measurement including O₂.
- Measuring range ratio max. 1:10 (except O₂)
- Measuring ranges are changeable between the specified minimum and maximum range
 Settable one range or two ranges
 * In measurement range, low range is called 1st range, high range is called 2nd range.

Measured value indication:

- Digital indication in 4 digits (LCD panel with LED back light)
- Instantaneous value of each component
 - Instantaneous value after O₂ correction (only in NO, SO₂, CO measurement with O₂)
 - Average value after O₂ correction (only in NO, SO₂, CO measurement with O₂)
 - O₂ average value

Analog output signals:

4 to 20mA DC or 0 to 1V DC, isolated internally from circuit and ground. Output lines are non-isolated each other.; 4 outputs max.
 Allowable load 550Ω for 4 to 20mA DC
 Allowable load 100kΩ for 0 to 1V DC
 * Refer to Section 5.3 (3) "Contents of measured channel (CH)" for the channel No. of displayed values and analog output signals.

Analog input signal:

For signal input from externally installed O₂ analyzer.
 Signal requirement;
 (1) Signal from Fuji's Zirconia O₂ analyzer (TYPE: ZFK7)
 (2) 0 to 1V DC from an O₂ analyzer
 Input section is not isolated. This feature is effective when an O₂ analyzer is not built in.
 * Externally installed O₂ analyzer should be purchased separately.

Digital output: (Horizontal type) (Option)

1c contact (24V DC/1A, resistive load) max. 15 outputs
 Instrument error, calibration error, range identification, auto calibration status, solenoid valve drive for auto calibration, High/Low limit alarm contact output

* All relay contacts are isolated mutually and from the internal circuit.

Digital output: (Vertical type) (Standard)

1a contact (250V AC/2A, resistive load)
 Instrument error, calibration error, range identification, auto calibration status, pump on/off, solenoid valve drive for auto calibration

* All relay contacts are isolated mutually and from the internal circuit.

1c contact (250V AC/2A, resistive load)
 High/Low limit alarm contact output, power ON/OFF status

* All relay contacts are isolated mutually and from the internal circuit.

Digital input: (Horizontal type) (Option)

Voltage contact (supply 12-24VDC (15mA Max.)) max. 9 inputs

Remote range change over, auto calibration remote start, remote hold, average value reset, Isolated from the internal circuit with photocoupler.

Digital input: (Vertical type) (Standard)

No-voltage contact (ON/0V, OFF/5VDC, 5mA flowing at ON.)

* For ZRG : (ON/5VDC, OFF/0V)
 Remote range change over, aut calibration remote start, remote hold, average value reset, Isolated from the internal circuit with photocoupler. Contact inputs are not isolated from one another.

Power supply:

Voltage rating ; 100V to 240V AC
 Allowable range ; 85V to 264V AC
 Frequency ; 50Hz/60Hz
 Power consumption ; 100VA max.

Operation conditions:

Ambient temperature ; -5°C to 45°C
 Ambient humidity ; 90% RH max., non-condensing

Storage conditions:

Ambient temperature ; -20°C to 60°C
 Ambient humidity ; 100% RH max., non-condensing

Dimensions (H × W × D):

133 x 483 x 382mm (Horizontal type)
835 x 218 x 202mm (Vertical type)

Mass: Approx. 11 kg max. (Horizontal type)
Approx. 16 kg max. (Vertical type)

Finish color: Front panel; Cool gray (PANTON 1C-F)

Enclosure: Steel casing, for indoor use

Material of gas-contacting parts:

Gas inlet/outlet; SUS304
Sample cell; SUS304, chloroprene rubber
Infrared-ray transmitting window; CaF2
Paramagnetic O₂ analyzer cell; SUS316
Fuel cell O₂ analyzer cell; ABS resin
Internal piping; Toaron, Teflon, Polypropylene

Solenoid valve; fluoro-rubber

Gas inlet/outlet: Rc1/4 or NPT1/4 internal thread

Purge gas flow rate: 1L/min (when required)

Life time of fuel cell O₂ analyzer: 2 years

2. Standard Functions

Output signal holding:

Output signals are held unchanged during manual and auto calibrations by activation of holding (turning "ON" its setting).

The values held are those just before start calibration mode or setting value.

Usage is selectable.

Indication of instantaneous values will not be held.

Switch ranges: The switch ranges function is available in manual, auto, and remote modes. Only preset switch method is effective.

Manual: Allows range to switch by key operation.

Auto: Automatically switched from first range to second range when the measured value exceeds 90%FS of first range.

Automatically switched from second range to first range when the measured value drops to 80% or less first range.

Remote (Option):

Voltage contact input (for measurable components)

Allows range to switch via an external signal when remote range switch input is received.

When the contact input terminals for each component are input voltage, the first range is selected, and it is switched to the second range when the terminals are open.

* These switch range value are settable between the first range and second range values (low/high range values).

3. Optional Functions

Remote output holding ^(*):

Output signal is held at the last value or preset value by voltage input to the remote output holding input terminals.

Holding is maintained while voltage is input to the terminals. Indication of instantaneous values are not held.

Range identification signal ^(*):

The present measuring range is identified by a contact position.

The contact output terminals close for each component when the first range is selected, and open when the second range is selected.

Auto calibration ^(*):

Zero and span calibration is carried out periodically at the preset cycle.

When a standard gas cylinder for calibration and solenoid valves for opening/closing the gas flow line are prepared externally by the customer, calibration will be carried out with the solenoid valve drive contacts for zero calibration and each span calibration turned on/off sequentially at the set auto calibration timing.

Auto calibration cycle setting:

Auto calibration cycle is set.
Setting is variable within 1 to 99 hours
(in increments of 1 hour) or 1 to 40 days
(in increments of 1 day).

Gas flow time setting:

The time for flowing each calibration gas
in auto calibration is set.
Settable within 60 to 900 seconds (in
increments of 1 second)

Auto calibration remote start ^(*):

Auto calibration starts by opening the
auto calibration remote start input terminal
after short circuiting for 1.5 sec or longer.
Auto calibration starts when contacts
open.

Auto zero calibration ^(*):

Auto zero calibration is carried out peri-
odically at the preset cycle.
This cycle is independent from "Auto
calibration" cycle.
When zero calibration gas and solenoid
valve for opening/closing the calibration
gas flow line are prepared externally by
the customer, zero calibration will be car-
ried out at the set auto zero calibration
timing.

Auto zero calibration cycle setting:

Auto zero calibration cycle is set.
Setting is variable within 1 to 99 hours
(in increments of 1 hour) or 1 to 40 days
(in increments of 1 day)

Gas flow time setting:

The timing for flowing zero gas in auto
zero calibration is set.
Settable within 60 to 900 seconds (in
increments of 1 second)

High/low limit alarm ^(*):

Alarm contact output turns on when
measurement value reaches the preset
high or low limit alarm value.
Contacts close when the instantaneous
value of each channel exceeds the high
alarm limit value or falls below the low
alarm limit value. (max. 5 (for Horizontal
type) or 6 (for Vertical type) alarms are
settable)

Instrument error contact output ^(*):

Contacts conductive at occurrence of
analyzer error No. 1, 2, 3 or 10.

Calibration error contact output ^(*):

Contacts conductive at occurrence of
manual or auto calibration error (any of
errors No. 4 to 9).

Auto calibration status contact outputs ^(*):

Contacts conductive during auto calibra-
tion.

O₂ correction:

Correction of measured NO, SO₂ and
CO gas concentrations into values at
reference O₂ concentration.

Correction formula:

$$C = \frac{21-O_n}{21-O_s} \times C_s$$

C : Sample gas concentration after O₂
correction

C_s : Measured concentration of sample
gas

O_s : Measured O₂ concentration (Limit
setting: 1 to 20% O₂)

O_n : Reference O₂ concentration
(value changeable by setting.0 to
19% O₂)

Average value after O₂ correction and O₂ average value calculation:

The result of O₂ correction or instan-
taneous O₂ value can be output as an
average value over the preset period of
time.

Moving average method is used. Sampling
interval is 30 seconds.

(Output is updated every 30 seconds.
Update is the averaged value of the most
recent elapsed averaging time period.)
Averaging time period is settable within 1
to 59 minutes (in increments of 1 minute)
or 1 to 4 hours (in increments of 1 hour).

Average value resetting:

The above-mentioned output of average
value is started from the initial state by
opening the average value resetting input
terminals after short circuiting for 1.5 sec
or longer.

Output is reset by input voltage and
restarted by opening the terminal circuit.

Communication function:

RS-485 (9pins D-sub connector)

Half-duplex bit serial

Start-stop synchronization

Modbus RTU™ protocol

Contents : Read/Write parameters
Read measurement concen-
tration and instrument status

Remark : When connecting via RS-
232C interface, an RS-232C
↔ RS-485 converter should
be used.

Atmospheric pressure correction:

Measure atmospheric pressure and cal-
culate compensation (for use, be sure to
relieve the exhaust gas from analyzer to
the atmosphere)

After atmospheric pressure correction;

Zero point : No influenced

Span point: The change is 0.5% mea-
sured value or less relating
to the change of the atmo-
spheric pressure 1%.

Correction range: 700hPa-1050hPa
And refer to section "3.4.4. Purging of
instrument inside".

*1 Standard function for Vertical type.

4. Performance

Repeatability:	±0.5% of full scale
Linearity:	±1% of full scale prior to atmospheric pressure correction (option)
Zero drift:	±0.5% of full scale/week (measurable component of NDIR) ±2.0% of full scale/week (O ₂ analyzer)
Span drift:	±2.0% of full scale/week
Response time (T₉₀) :	30 seconds or better Response interval may be changed de- pending on timing of the switching gas by sample switching operation. (Td=5-20 seconds)

Interference from other gases:

Sample switching design effectively minimizes interference. But it may occur depending on component gas and its concentration.

Preprocessing can further decrease influence in this case.

Contact manufacturer for application specific advice.

5. EC Directive Compliance (Horizontal type only)

The product conforms to the requirements of the Low Voltage Directive 2006/95/EC and EMC directive 89/336/EEC (as amended by Directive 92/31/EEC), both as amended by Directive 93/68/EEC.

It conforms to following standards for product safety and electromagnetic compatibility ;

EN61010-1 : 2010

Safety requirements for electrical equipment for measurement, control and laboratory use.

"Installation Category II"

"Pollution Degree 2"

EN61326-1 : 2006

Electrical equipment for measurement, control and laboratory use — EMC requirements.

CE

6. Requirements for Sample Gas

Flow rate:	1.0 ±0.2L / min
Temperature:	0 to 50°C
Pressure:	10 kPa or less (Gas outlet side should be open to the atmospheric air.)
Dust:	100 µg/Nm ³ or less in particle size of 0.3 µm or smaller
Mist:	Unallowable
Moisture:	For CO, NO, SO ₂ measurement: less than 2°C saturation point. For CO ₂ measurement: less than -30°C saturation point (with comparable moisture levels in sample and reference gases).

Corrosive component:

1 ppm or less

Standard gas for calibration:

Zero gas ; Dry N₂

Span gas ; Each sample gas having concentration 90 to 100% of its measuring range (recommended).

In case a zirconia O₂ analyzer is installed externally and calibration is carried out on the same calibration gas line:

Zero gas ; Dry air or atmospheric air (Do not use with CO₂ measurement)

Span gas ; For other than O₂ measurement, each sample gas having concentration 90 to 100% of its measuring range
For O₂ measurement, O₂ gas of 1 to 2 vol%/remains N₂ gas

Reference gas for sample switching:

NO, SO₂, CO measurement;

For sample gas dewpoint > 2°C sample switching reference gas is wet N₂.

For sample gas dewpoint < 2°C use dry N₂ or zero gas equivalent.

CO₂ measurement;

N₂ without CO₂ and moisture. (over 99.999999vol%)

Purge gas:

With CO₂ measurement, be sure to perform the purge in the analyzer with N₂.
And refer to section section 3.4.4. "Purging of instrument inside".

7. Installation Requirements

- Indoor use (Select a place where the equipment does not receive direct sunlight, draft/rain or radiation from hot substances. If such a place cannot be found, a roof or cover should be prepared for protection.)
- Avoid a place where unit receives heavy vibration
- Select a place where atmospheric air is clean

RANGE CODE

Range	Code
None	Y
0~5ppm	5
0~10ppm	6
0~20ppm	7
0~25ppm	8
0~30ppm	9
0~50ppm	A
0~100ppm	B

O₂ measurement range

Measurement range	Range code	Fuel cell O ₂ analyzer (built - in)	Paramagnetic O ₂ analyzer (built - in)	Zirconia O ₂ analyzer (external)
0~5/10 vol%	A		○	○
0~5/25 vol%	B		○	○
0~10/25 vol%	C	○	○	○
0~5 vol%	L		○	○
0~10 vol%	M	○	○	○
0~25 vol%	V	○	○	○
0~50 vol%	P		○	
0~100 vol%	R		○	
100~95 vol%	S		○	

note1)When "D" is specified at 4th digit, power supply cord is supplied in the scope of supply. Cord specification should be specified at the 20th digit.

And when "3" is specified at 4th digit, select "E" at 5th digit.

note2)When "1" is specified at 7th digit, O₂ analyzer signal has to be set as 0-1V DC linear corresponding to full scale. External zirconia O₂ analyzer and external O₂ analyzer are not included in the scope of supply, and has to be separately ordered.

note3)Select the range code for each range from the range code table shown above. Range of fuel cell O₂ analyzer is 0-10vol% or more.

note4)Select the type of voltage rating, plug type and applicable standard of the power supply cord by 20th digit. Select a power supply cord for using at the location of end-user.

note5)O₂ correction is calculated only for NO, SO₂ and CO.

note6)When "B" is specified at 24th digit, measuring range should be specified by ppm range code. In this case NO, SO₂ and CO measuring range are corresponding range in mg/m³. Please refer to the table shown below for the corresponding range code based on "mg/m³".

note7)When "A" is specified at 25th digit, the analyzer will be adjusted and delivered with the balance gas N₂. When other adjustment is required, please specify "Z". When "Z" is specified, please attach a list of gas composition contained in the measuring gas.

Corresponding mg/m³

Range code	Unit : ppm	Corresponding range in mg/m ³		
		NO	SO ₂	CO
5	0-5ppm	—	—	0-6.00mg/m ³
6	0-10ppm	0-13.0mg/m ³	0-28.0mg/m ³	0-12.5mg/m ³
7	0-20ppm	0-26.0mg/m ³	0-57.0mg/m ³	0-25.0mg/m ³
8	0-25ppm	0-32.5mg/m ³	0-70.0mg/m ³	0-30.0mg/m ³
9	0-30ppm	0-40.0mg/m ³	0-85.0mg/m ³	0-37.5mg/m ³
A	0-50ppm	0-65.0mg/m ³	0-140.0mg/m ³	0-60.0mg/m ³
B	0-100ppm	0-130.0mg/m ³	0-280.0mg/m ³	0-125.0mg/m ³

The conversion formula "ppm" unit into "mg/m³" unit.

NO (mg/m³) = 1.34 × NO (ppm)

SO₂ (mg/m³) = 2.86 × SO₂ (ppm)

CO (mg/m³) = 1.25 × CO (ppm)

<Vertical type>

Digit	Description	note	1	2	3	4	5	6	7	8	9	10	11	12	13	14	15	16	17	18	19	20	21	22	23	24	25
4	<Specification/structure> Vertical type (Replace for ZRG sample switching type)		Z	P	G	3	E			1																	
5	<Mounting> Wall mounting type						E																				
6	<Measurable component (NDIR)> NO SO ₂ CO ₂ CO Others							P A D B Z																			
7	<Measurable component (O ₂)> None External O ₂ analyzer External zirconia O ₂ analyzer (ZFK7) Built-in fuel cell O ₂ analyzer Built-in paramagnetic O ₂ analyzer	note1							Y 1 2 3 4																		
8	<Revision code>									1																	
9	<Measuring range (NDIR)> 1st component, 1st range	note2																									
10	<Measuring range (NDIR)> 1st component, 2nd range	note2																									
11	<Unused digit>												Y														
12	<Unused digit>													Y													
13	<Unused digit>														Y												
14	<Unused digit>															Y											
15	<Unused digit>																Y										
16	<Unused digit>																	Y									
17	<Measuring range (O ₂)> None 0-5/10% 0-5/25% 0-10/25% 0-5% 0-10% 0-25% 0-50% 0-100% 100-95% Others																		Y A B C L M V P R S Z								
18	<Gas connection> Rc1/4 NPT1/4																			1 2							
19	<Output> 0-1V DC 4-20mA DC 0-1V DC + Communication function 4-20mA DC + Communication function																				A B C D						
20	<Language/power supply cord> In Japanese (Power supply cord is not delivered) In English (Power supply cord is not delivered)																				J E						
21	<O ₂ correction and O ₂ correction average output> None O ₂ correction O ₂ correction average O ₂ correction + O ₂ correction average	note3 note3 note3																					Y A B C				
22	<Optional function (DIO)> FAULT A. Cal. H/L Alarm RangeID/Remote range <input type="radio"/> <input type="radio"/> <input type="radio"/> <input type="radio"/>																								3		
23	<Pressure compensation> None Pressure compensation																								Y 1		
24	<Unit> ppm, vol% mg/m ³ , g/m ³	note4																								A B	
25	<Adjustment> For standard (N ₂ balance)																										A

<RANGE CODE> (for NDIR component)

measurement range	Code
0~5ppm	5
0~10ppm	6
0~20ppm	7
0~25ppm	8
0~30ppm	9
0~50ppm	A
0~100ppm	B

note1)When '1' is specified at 7th digit, O₂ analyzer signal has to be set as 0-1V DC linear corresponding to full scale.
External zirconia O₂ analyzer and external O₂ analyzer are not included in the scope of supply, and has to be separately ordered.

note2)Select the range code for each range from the range code table shown above.
Range of fuel cell O₂ analyzer is 0-10% or more.

note3)O₂ correction is calculated only for NO, SO₂, CO.

note4)When 'B' is specified at 24th digit, measuring range should be specified by ppm range code.
In this case NO, SO₂ and CO measuring range are corresponding range in mg/m³.
Please refer to the table shown below for the corresponding range code based on 'mg/m³'.

Corresponding mg/m³

Range code	Unit : ppm	Corresponding range in mg/m ³		
		NO	SO ₂	CO
5	0-5ppm	—	—	0-6.25mg/m ³
6	0-10ppm	0-13.4mg/m ³	0-28.6mg/m ³	0-12.5mg/m ³
7	0-20ppm	0-26.8mg/m ³	0-57.2mg/m ³	0-25.0mg/m ³
8	0-25ppm	0-33.5mg/m ³	0-71.5mg/m ³	0-31.25mg/m ³
9	0-30ppm	0-40.2mg/m ³	0-85.5mg/m ³	0-37.5mg/m ³
A	0-50ppm	0-67.0mg/m ³	0-143.0mg/m ³	0-62.5mg/m ³
B	0-100ppm	0-134.0mg/m ³	0-286.0mg/m ³	0-125.0mg/m ³

The conversion formula "ppm" unit into "mg/m³" unit.
 NO (mg/m³) = 1.34 × NO (ppm)
 SO₂ (mg/m³) = 2.86 × SO₂ (ppm)
 CO (mg/m³) = 1.25 × CO (ppm)

9.3 Outline diagram (Unit : mm)

<Horizontal type>

<TOP VIEW>

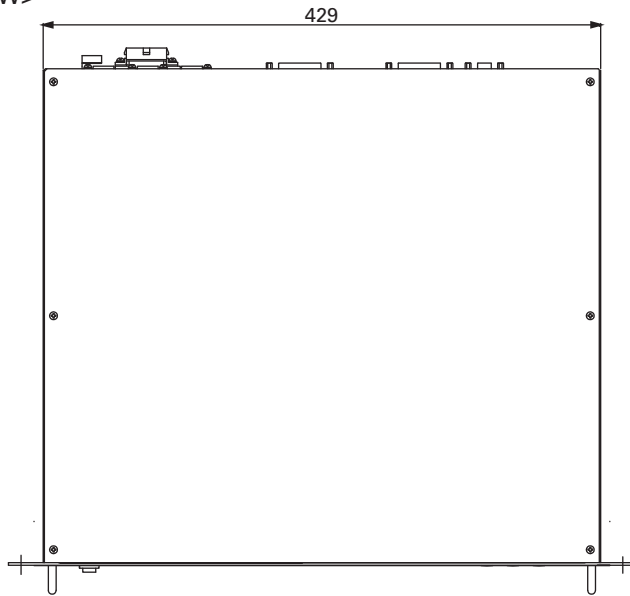

<FRONT VIEW>

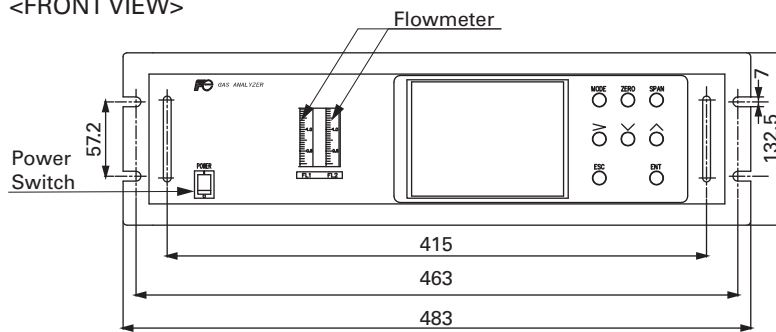

<REAR VIEW>

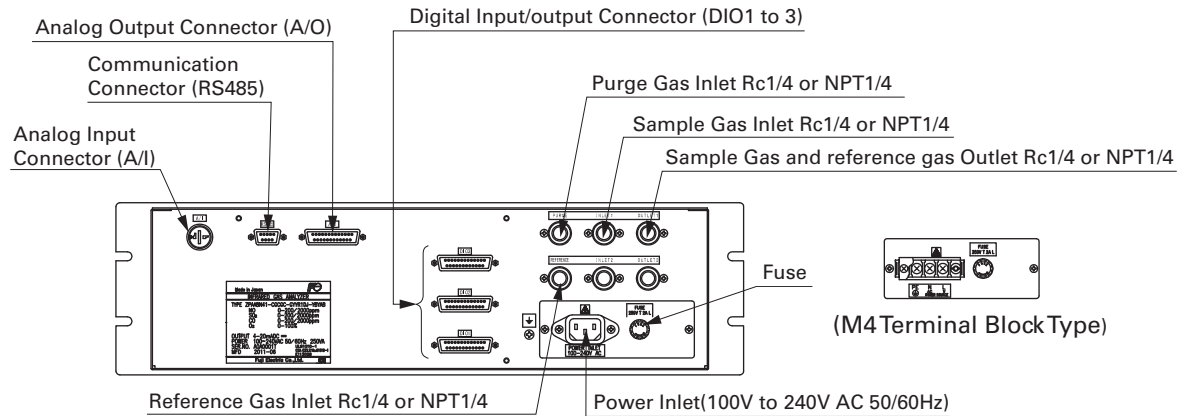

<SIDE VIEW>

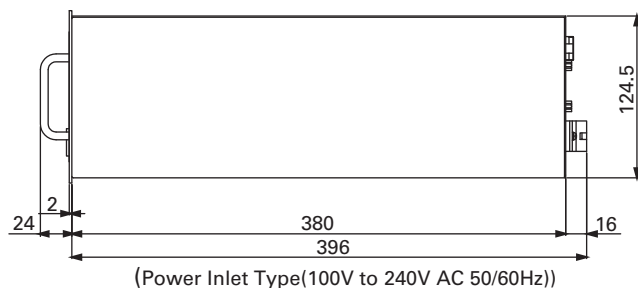

Mounting method

The analyzer weight should be supported at the bottom of the case.

19-inch rack mounting type

<Rack dimensions>

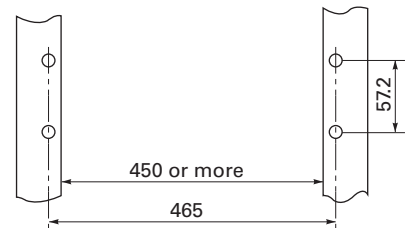

Mounting diagram

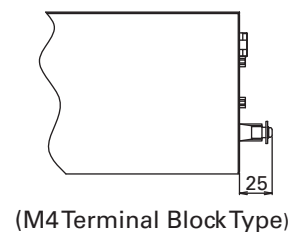
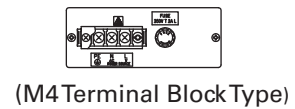
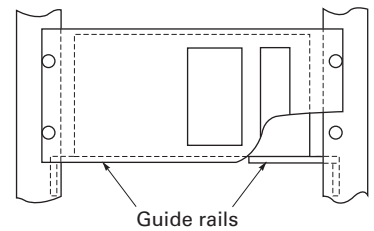
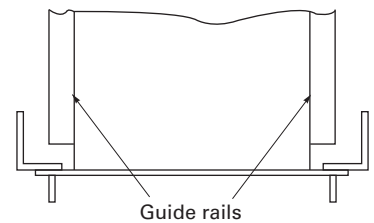

<Vertical type>

<TOP VIEW>

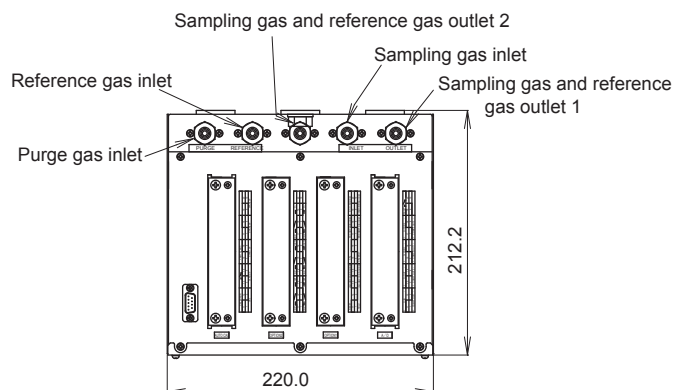

Mounting method

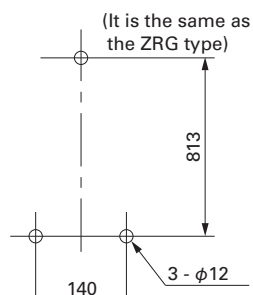

M10 screw is needed for mounting the main unit

<FRONT VIEW>

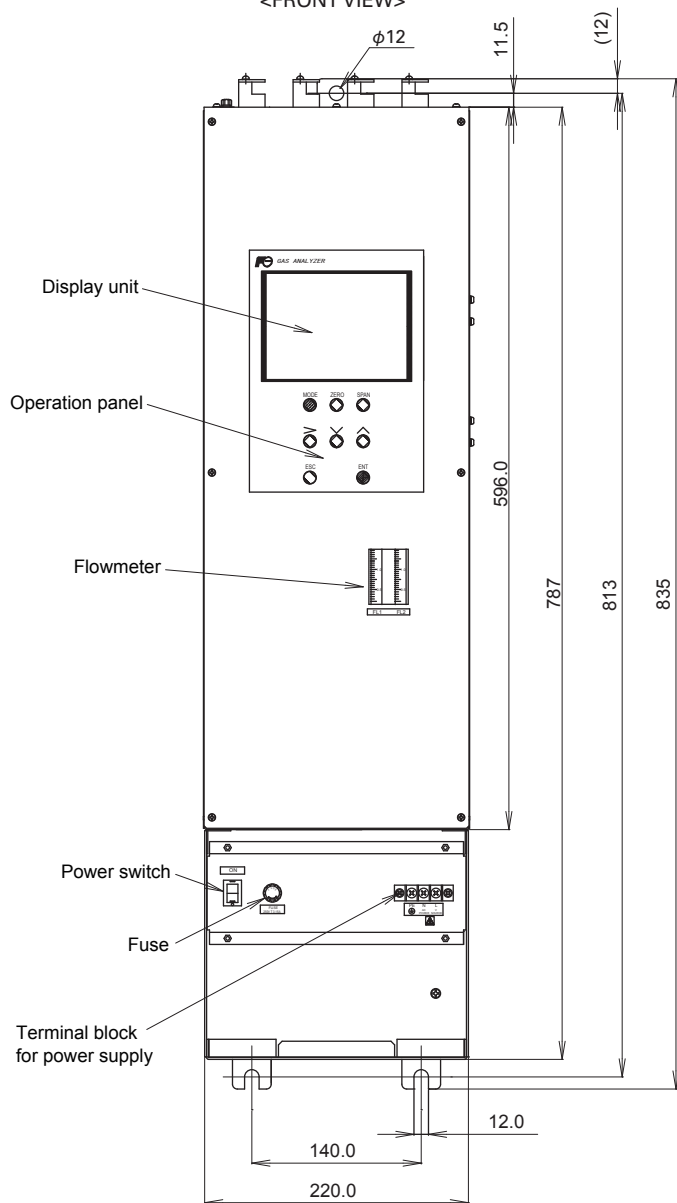

<SIDE VIEW>

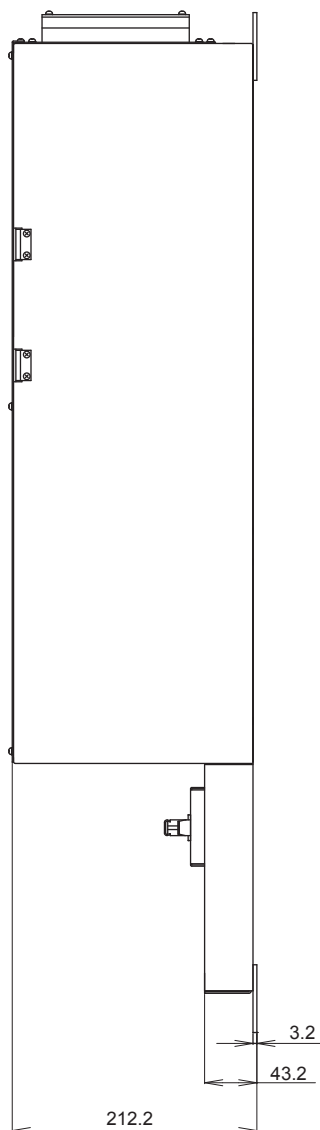

Fuji Electric Co., Ltd.

Global Sales Section

Instrumentation & Sensors Planning Dept.

1, Fuji-machi, Hino-city, Tokyo 191-8502, Japan

<http://www.fujielectric.com>

Phone: +81-42-514-8930 Fax: +81-42-583-8275

<http://www.fujielectric.com/products/instruments/>
